

Tubeaxial - Belt Drive Model TXB - 091

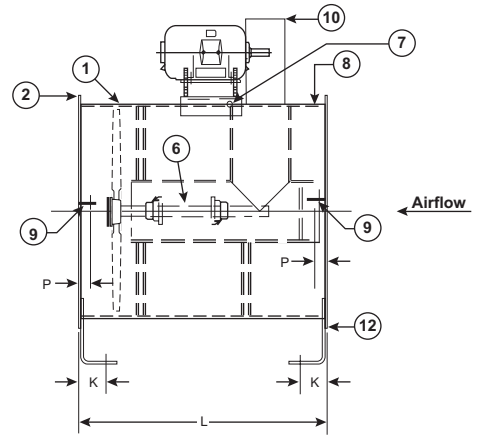
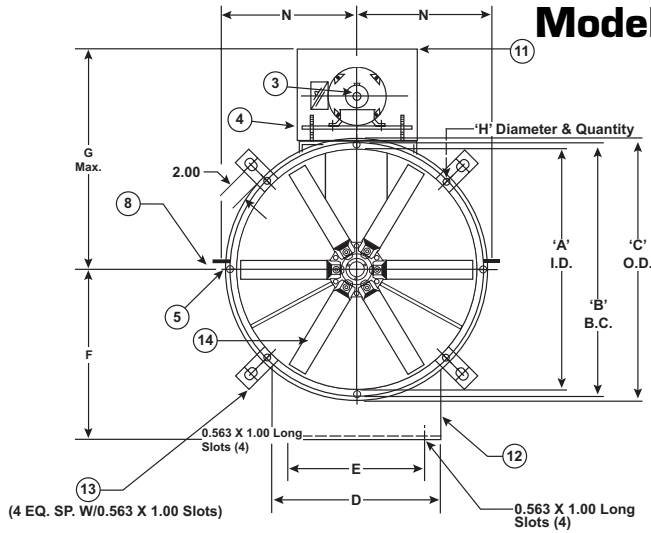

Legend

- | | | |
|-------------------------------|--|---|
| 1. Steel Fan Casing | 6. Fan Shaft & Bearings | 10. Belt Guard (optional) |
| 2. Duct Flanges | 7. Extended Lube Lines | 11. Motor Cover (optional) |
| 3. Ball Bearing Motor | 8. "J" Gage | 12. Horizontal Mounting Legs (optional) |
| 4. Motor Support Plate | 9. Horizontal Ceiling Clips (optional, for motor positions A & E only) | 13. Vertical Mounting Legs (optional) |
| 5. Duct Flange Mounting Holes | | 14. Cast Aluminum Prop (Type "L") |

Dimensional Data

Size	A	B	C	D	E	F	G	H	J	K	L. Mtr. Frame Size				N	P	(1) Unit Weight
											Design 1	Max. Mtr.	Design 2	Max. Mtr.			
012	12.19	13.50	14.38	11.00	9.00	11.00	26.00	.438-8	14	1.68	—	184	—	—	7.19	3.08	100
015	15.19	16.50	17.44	14.00	12.00	13.00	27.50	.438-8	12	1.71	24.00	184	—	—	8.69	3.10	150
018	18.19	19.81	21.19	17.00	15.00	14.50	30.00	.438-8	12	1.71	28.00	215	—	—	10.16	3.10	200
021	21.22	22.97	24.22	20.00	18.00	16.00	31.50	.438-8	12	1.71	28.00	215	—	—	12.17	3.10	250
024	24.25	26.06	27.25	22.00	18.00	18.00	36.25	.438-8	12	1.71	28.00	215	32.00	286	13.69	3.10	300
027	27.28	29.13	30.28	26.00	22.00	20.00	37.75	.438-8	12	1.71	28.00	215	32.00	286	15.22	3.10	350
030	30.31	32.19	33.31	29.00	25.00	21.50	40.25	.438-8	12	1.71	28.00	215	36.00	286	16.74	3.10	500
032	32.34	34.19	35.34	31.00	27.00	23.00	42.75	.438-16	12	1.71	28.00	256	36.00	286	17.75	3.10	550
036	36.38	38.19	39.38	35.00	31.00	25.00	44.75	.438-16	10	1.73	36.00	256	42.00	326	19.75	3.13	850
042	42.44	44.81	46.44	40.00	36.00	29.00	49.25	.563-16	10	1.73	36.00	286	42.00	326	23.28	3.13	1050
048	48.50	50.88	52.50	46.00	42.00	33.25	54.25	.563-16	10	1.73	42.00	286	48.00	405	26.31	3.13	1400
054	54.56	57.00	58.56	52.00	48.00	36.25	57.25	.563-16	7	1.78	48.00	286	54.00	405	29.38	3.18	2150
060	60.63	63.00	64.63	56.00	52.00	39.25	60.25	.563-16	7	1.78	48.00	286	54.00	405	32.38	3.18	2500
072	72.75	75.13	76.88	60.00	56.00	45.38	66.25	.563-16	0.25	1.78	48.00	286	54.00	405	39.38	4.00	3500
084	84.88	87.63	89.38	66.00	62.00	51.38	72.25	.563-24	0.25	1.78	54.00	286	60.00	405	45.44	4.00	4300
096	97.00	99.75	101.50	72.00	68.00	57.38	78.25	.563-24	0.25	1.78	54.00	286	60.00	405	51.50	4.50	5000

(1) Approximate fan weights are less motors, drives and accessories. See "Estimated Shipping Weights" supplement for estimated motor shipping weights.

<p style="margin: 0;">PENNBARRY™</p> <p style="margin: 0;">1401 North Plano Road, Richardson, TX 75081 Ph: 972.234.3202 Fax: 972.497.0468 www.PennBarry.com</p>	<h2 style="margin: 0;">Submittal Sheet</h2> <h3 style="margin: 0;">Model TXB - 091 Tubeaxial Belt Drive</h3>
--	--

This drawing illustrates our understanding of order requirements. When approved, it represents details for fabrication, as such, PennBarry will not be responsible for revisions in the field or other changes after release for fabrication. Published and protected by PennBarry, Richardson, TX. All rights reserved. May not be reproduced partially or in full without permission from the publisher. No rights conveyed to manufacture partially or in full, use or sell either the method of construction represented or any invention in any way related thereto.