



Please read and save these instructions. Read carefully before attempting to assemble, install, operate or maintain the product described. Protect yourself and others by observing all safety information. Failure to comply with instructions could result in personal injury and/or property damage! Retain instructions for future reference.

# Airette | Gravity Ventilators

## Intake & Relief



### › Receiving and Handling

PennBarry ventilators are carefully inspected before leaving the factory. When the unit is received, inspect for any signs of tampering. Inspect the unit for any damage that may have occurred during transit and check for loose, missing or damaged parts. Mishandled units can void the warranty provisions. PennBarry is not responsible for damages incurred during shipment.

Avoid severe jarring and/or dropping. Handle units with care to prevent damage to components or special finishes.

### › Storage

Long-term storage requires special attention. Units should be stored on a level, solid surface, preferably indoors. If outside storage is necessary, protect the units against moisture and dirt by encasing in plastic or some similar weatherproof material.

### › Installation | Dampers

When required, install dampers prior to mounting the unit on the curb or frame. Secure dampers to the inside of the curb without undue twisting, which may distort the damper frame. Damper frame must be reasonably level on all sides. Check for free operation. If dampers are motor operated type, ascertain that proper voltage is impressed on motor terminals.

### › Positioning & Running Power Lines

When power lines are brought up to the unit, provide a generous amount of slack to allow for movement. Protect power lines from sharp objects. Do not kink power line or permit it to contact hot surfaces, chemicals, grease or oil. Use only UL recognized electrical parts, rated for proper voltage, load and environment.

Power is normally brought from within the building and placed inside one corner of the curb. Feed power line through the clearance hole provided in the damper and in turn through the ventilator.

### › Anchoring Or Securing The Unit

Whenever possible, anchor the ventilator by fastening through the vertical portion of the mounting flange. The type, size and number of fasteners depends upon the unit size and curb construction. If code or specification prescribes fastening through the top (horizontal portion) of the mounting flange, use neoprene or lead washers under the head of each fastener to prevent water leaks.

**CAUTION** Guy down large units installed in areas subject to high winds or unusual field conditions.

If the contractor removes ventilator parts to facilitate installation and electrical connections, all parts should be reassembled by replacing all spacers, washers, nuts, bolts, fasteners and components exactly as they were found prior to removal. All fasteners are to be drawn tight and secure. The ventilator is now ready for service.

### › Maintenance

The only maintenance required is an occasional painting as a rust-preventative measure.

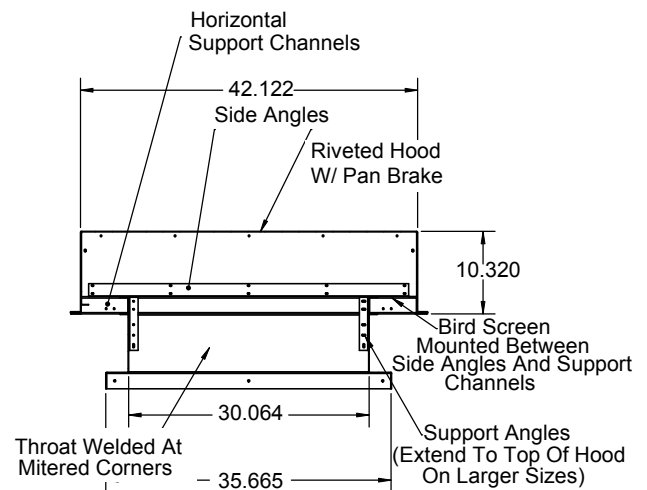
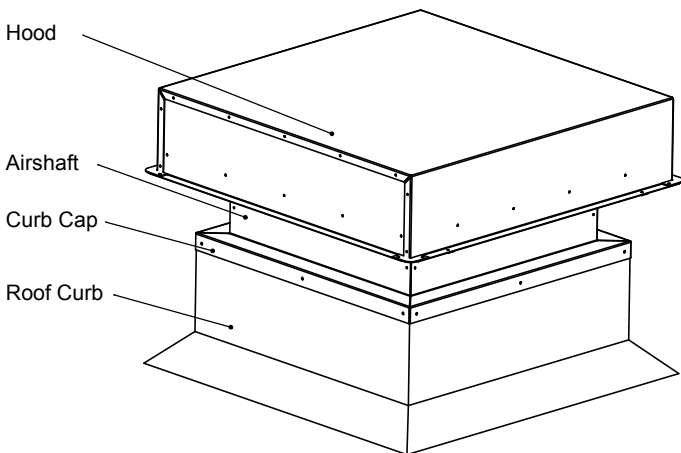

# Limited Warranty

## › What Products Are Covered

PennBarry Fans and Ventilators (each, a “PennBarry Product”)

## › One Year Limited Warranty For PennBarry Products

PennBarry warrants to the original commercial purchaser that the PennBarry Products will be free from defects in material and workmanship for a period of one (1) year from the date of shipment.

## › Exclusive Remedy

PennBarry will, at its option, repair or replace (without removal or installation) the affected components of any defective PennBarry Product; repair or replace (without removal or installation) the entire defective PennBarry Product; or refund the invoice price of the PennBarry Product. In all cases, a reasonable time period must be allowed for warranty repairs to be completed.

## › What You Must Do

In order to make a claim under these warranties:

1. You must be the original commercial purchaser of the PennBarry Product.
2. You must promptly notify us, within the warranty period, of any defect and provide us with any substantiation that we may reasonably request.
3. The PennBarry Product must have been installed and maintained in accordance with good industry practice and any specific PennBarry recommendations.

## › Exclusions

These warranties do not cover defects caused by:

1. Improper design or operation of the system into which the PennBarry Product is incorporated.
2. Improper installation.
3. Accident, abuse or misuse.
4. Unreasonable use (including any use for non-commercial purposes, failure to provide reasonable and necessary maintenance as specified by PennBarry, misapplication and operation in excess of stated performance characteristics).
5. Components not manufactured by PennBarry.

## › Limitations

1. In all cases, PennBarry reserves the right to fully satisfy its obligations under the Limited Warranties by refunding the invoice price of the defective PennBarry Product (or, if the PennBarry Product has been discontinued, of the most nearly comparable current product).
2. PennBarry reserves the right to furnish a substitute or replacement component or product in the event a PennBarry Product or any component of the product is discontinued or otherwise unavailable.
3. PennBarry’s only obligation with respect to components not manufactured by PennBarry shall be to pass through the warranty made by the manufacturer of the defective component.

## › General

**The foregoing warranties are exclusive and in lieu of all other warranties except that of title, whether written, oral or implied, in fact or in law (including any warranty of merchantability or fitness for a particular purpose).**

**PennBarry hereby disclaims any liability for special, punitive, indirect, incidental or consequential damages, including without limitation lost profits or revenues, loss of use of equipment, cost of capital, cost of substitute products, facilities or services, downtime, shutdown or slowdown costs.**

The remedies of the original commercial purchaser set forth herein are exclusive and the liability of PennBarry with respect to the PennBarry Products, whether in contract, tort, warranty, strict liability or other legal theory shall not exceed the invoice price charged by PennBarry to its customer for the affected PennBarry Product at the time the claim is made.

*Inquiries regarding these warranties should be sent to: PennBarry, 605 Shiloh Rd, Plano, TX 75074.*