

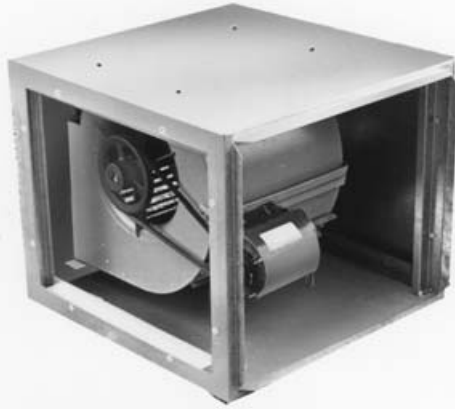

PENNBARRY

Please read and save these instructions. Read carefully before attempting to assemble, install, operate or maintain the product described. Protect yourself and others by observing all safety information. Failure to comply with instructions could result in personal injury and/or property damage! Retain instructions for future reference.

Zephyr Belt Drive Cabinet Fans Models ZC & ZCC



Receiving and Handling

PennBarry fans are carefully inspected before leaving the factory. When the unit is received, inspect the carton for any signs of tampering. Inspect the unit for any damage that may have occurred during transit and check for loose, missing or damaged parts. Mishandled units can void the warranty provisions. PennBarry is not responsible for damages incurred during shipment.

Avoid severe jarring and/or dropping. Handle units with care to prevent damage to components or special finishes.

Storage

Long-term storage requires special attention. Units should be stored on a level, solid surface, preferably indoors. If outside storage is necessary, protect the units against moisture and dirt by encasing the cartons in plastic or some similar weatherproof material. Periodically inspect units and rotate wheels to spread bearing lubricant. Failure to rotate wheels can result in reduced bearing life and may void the manufacturer's warranty. If the unit will be stored for extended time, remove all belts.

Unpacking

Place carton in an upright position and remove staples or use a sharp (knife edge) tool to CAREFULLY cut or scribe the sealing tape on both sides at the top of the carton. Open carton flaps. Remove any cardboard and wooden filler pieces, as well as loose components or accessories shipped with the unit.

Carefully remove the unit from the carton. Inspect the unit for any damage that may have occurred during transit and check for loose, missing or damaged parts.

Description

PennBarry Zephyr series ZC and ZCC belt drive cabinet fans are general purpose duct blowers. For general ventilating use only. DO NOT USE to exhaust dirt, grease or lint-laden air. These units are sized with space saving in mind and furnished with inlet and outlet connecting flanges and removable access panels on either side of the unit. Complete motor and blower assembly can be removed for full accessibility to all components for servicing, inspection, etc., using the side access panels. Optional accessories include a duct mounted filter assembly, guards and backdraft dampers.

Installation

Position unit to allow a minimum of 30" clearance for the side access panels on the unit. PennBarry ZC fans are supplied with four (4) pre-punched mounting holes which should be utilized as the point of attachment. For installation purposes, use four (4), 3/8" diameter threaded steel

rods, supplied by others (see Figure 1). Attach the rods securely into the ceiling panel or joist system and cut to length so the fan will hang in a level plane. To mount the unit, first put a nut and washer on each rod. Position the fan to hang level, with the rods extending through the mounting rail holes. Place another washer and nut onto the rods from inside the housing. Tighten nuts to lock the unit in place (see Figure 2).

If vibration isolators are required, they should be attached to the hanger rods before the unit is installed.

On dual unit Zephyr cabinet fans (Model ZCC), support channels provide the point of attachment instead of mounting holes (see Figure 3). Model ZCC units are pre-assembled with a joiner angle and two (2) support channels connecting the two units. Use four (4) 3/8" diameter threaded steel rods (supplied by others) for installation purposes. Attach the rods securely to the ceiling panel or joist system and cut to length so the fan will hang in a level plane. Mount the unit in place using the holes provided in the support channels and use nuts and washers, as described above, to lock the unit in place.

Figure 1: Hanging Unit Attachment

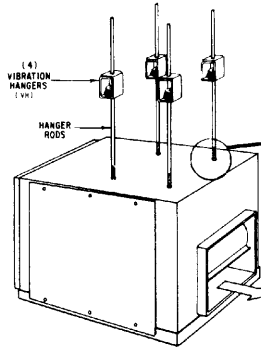

Figure 2: Rod Attachment

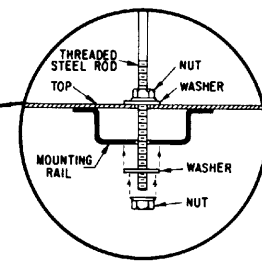
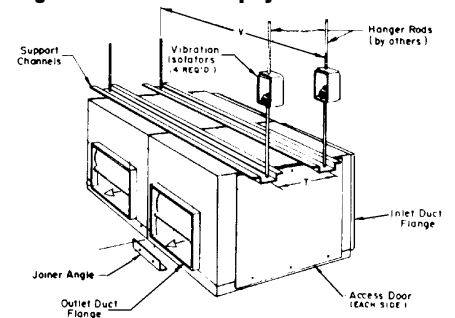

Table 1: Hanging Unit Attachment Dimensions

Model	T	V
ZCC10	13 3/8	48 1/2
ZCC12	16 1/8	58
ZCC15	19 1/2	71
ZCC18	24	88

All dimensions are in inches.

Figure 3: Dual unit Zephyrs



For floor installation, lag through bottom of cabinet into floor. If rubber vibration isolators (supplied by others) are used they should be located so the cabinet rests on them. Lag isolators to floor and bolt the fan to them using hardware adequate for attachment.

NOTE: Some local codes prohibit the connection of in-line, aluminum fans in kitchen hood exhaust systems. According to present NFPA 96 interpretation, ANY fan used in such duct work must be made of steel, with liquid-tight welds at all seams and connections. If local codes are in accordance with NFPA 96 do not use ANY FAN that is not completely welded closed for such duty. Refer to Penn Fumex Bulletin FMX99 for roof and wall mounted exhausters approved for use on kitchen hood exhaust.

Figure 4: Do Not Install In A Cooking Area

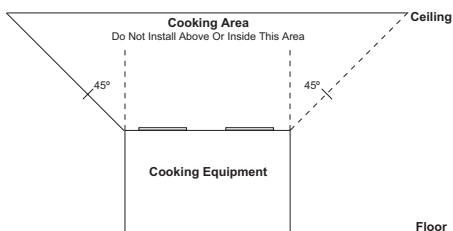

CAUTION Do not install in the kitchen area.

Wiring

Before wiring fan, LOCK OUT ALL POWER SOURCES. Normally power lines are brought up to the fan through proper conduit lines.

When performing any electrical wiring, follow all local and national electrical and safety codes, as well as the most recent National Electrical Code (NEC) and the Occupational Safety and Health Act (OSHA).

All wiring should be performed by a qualified electrician.

When power lines are brought to the unit, a generous amount of slack should be provided to allow for motor deflections and to permit movement of motor for belt tension adjustments. Motor must be securely and adequately grounded. Protect power lines from sharp objects. Do not kink power line or permit it to contact hot surfaces, chemical, grease or oil. Use only UL recognized electrical parts - rated for proper voltage, load and environment.

CAUTION Make sure that the proper line voltage is supplied to the fan.

Start Up and Operation

Careful inspection should be made before start-up. All fasteners should be securely tightened. Impeller should be rotated by hand to insure free movement. (NOTE: Before placing hand on impeller or belts, lock out primary and secondary power source.) Check all set-screws and keys. Tighten when necessary using proper tools to recommended torque.

The condition of belts and the amount of belt tension should be checked prior to start-up. When it becomes necessary to adjust belt tension, do not overtighten as bearing damage will occur. Recommended belt tension should permit 1/64" per inch of span deflection of the belt on each side of the pulley centerline (See Figure 6). Extreme care must be exercised when adjusting belt as not to misalign the pulleys. Any misalignment will cause a sharp reduction in belt life and will also produce squeaky, annoying noises. On units equipped with two-groove pulleys, use matching belts and adjust so there is equal tension on both belts.

Figure 6: Pulley Alignment & Tension

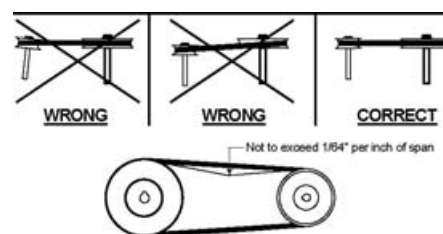
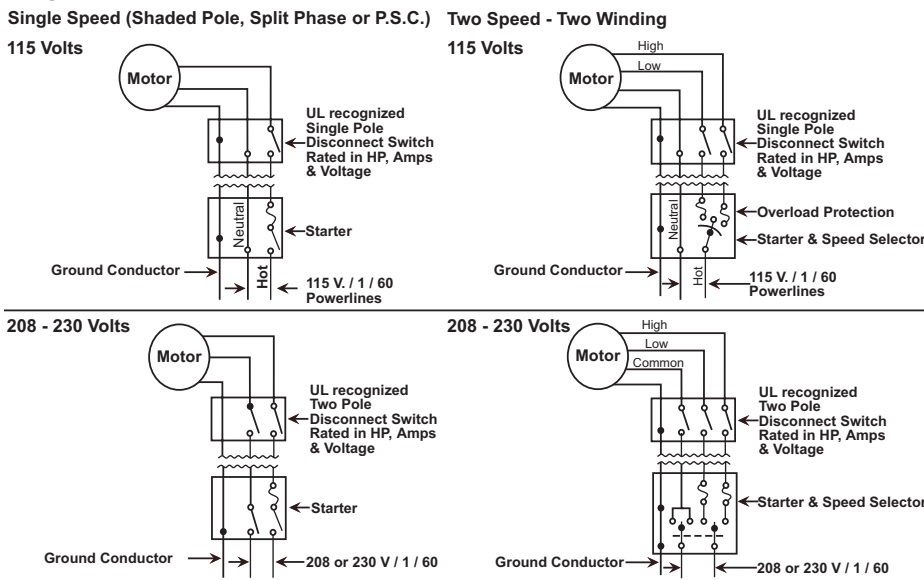
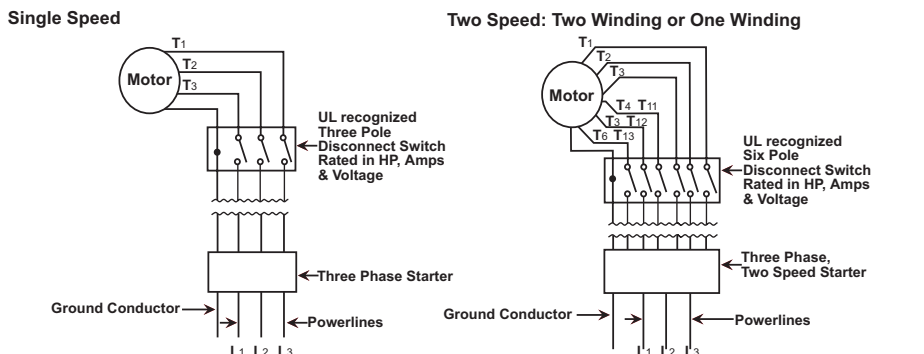

Figure 5: Wiring Diagram for Single Phase Models

Single Phase: Disconnect Switch between the motor and the starter



Single Phase: Disconnect Switch between the motor and the starter



BELT AND PULLEY ALIGNMENT

CAUTION Whenever belts are removed or installed, never force belts over pulleys without loosening motor first to relieve belt tension. The fan has been checked at the factory prior to shipment for mechanical noises. If mechanical noise should develop, the following suggestions are offered here as a guide toward remedying the cause.

1. Check rotating members for adequate clearance.
2. Check proper belt tension and pulley alignment.
3. Check installation and anchoring.
4. Check fan bearings.

The inlets and approaches to the exhauster should be free from obstructions. To assure maximum air movement, adequate supply air must be available.

Before putting fan into operation, complete the following check list:

- a. Turn off and LOCK OUT power source.
- b. Make sure installation is in accordance with manufacturer's instructions.
- c. Check and tighten all fasteners.
- d. Spin wheel to see if rotation is free.
- e. Check all set-screws and keys: tighten if necessary.
- f. Torqued set screws have a colored Torque Seal mark indicating the correct torque has been applied.
- g. Check belt or direct drive coupling for alignment (use recommended belt tension gauges).
- h. Check belt for proper sheave selection.
- i. Make sure there is no foreign or loose material in ductwork leading to and from fan or in the fan itself.
- j. Properly secure all safety guards.
- k. Secure all access doors to fan and ductwork.
- l. Check line voltage with motor nameplate.
- m. Check wiring.

NOTE: On single phase motors, the terminal block must be arranged in accordance with the nameplate instructions and/or wiring diagram. The arrangement must match the line voltage. If the motor is multi-speed or multi-voltage, the winding leads must be grouped and connected as shown on the wiring diagram. The line voltage must correspond with proper grouping of motor leads. The wiring diagram must be followed explicitly or serious motor or starter damage will occur.)

Switch on electrical supply and allow fan to reach full speed. Check carefully for:

1. Correct rotation of the wheel. NOTE: incorrect rotation results in severely diminished air flow. Check rotation label on unit.
To change rotation of 3 phase units, interchange any 2 of the 3 line leads. On single phase units, change the terminal block connections following the wiring diagram on the motor.
2. Check motor and bearing temperatures so that they are not excessively hot. NOTE: Use care when touching the exterior of an operating motor. Modern motors normally run hot. They are designed to operate at higher temperatures. This is a normal condition, but they may be hot enough to be painful or injurious to the touch.

If any problem is indicated, TURN OFF POWER TO UNIT IMMEDIATELY. Lock out the electrical supply, check carefully for the cause of the trouble and correct as needed. Even if the fan appears to be operating satisfactorily, shut down after a brief period and check all fasteners, set-screws and keys for tightness.

The fan may now be put into operation but during the first eight (8) hours of running it should be periodically observed and checked for excessive vibration or noise. At this time, checks should also be made on motor input current and motor bearing temperatures to insure they do not exceed manufacturer's recommendations. After eight hours of satisfactory operation the fan should be shut down and the electrical power locked out to check the following items and adjust if necessary:

- a. All set-screws, keys and fasteners.
- b. Drive coupling alignment.
- c. Belt drive alignment.
- d. Belt tension.

Maintenance

Do not attempt maintenance on a fan until the electrical supply has been completely disconnected. Lubrication is a primary maintenance responsibility. Check all bearings periodically. Inspect belts for tightness. If the fan is installed in a corrosive or dirty atmosphere, periodically clean the centrifugal wheel, inlet, motor housing and other moving parts.

FAN SHAFT LUBRICATION

Fan shaft bearing pillow blocks are furnished in either the pre-lubricated sealed-for-life type or the greasable type depending on what was ordered. The pre-lubricated type requires no servicing for 7 to 10 years of normal use and the greasable type are factory greased eliminating the need for greasing initially. Follow the lubricating schedule recommended by the factory. This practice should not supersede any safety considerations.

CAUTION Use low pressure grease guns only. High pressure guns tend to blow out or unseat bearing seals, leaving the bearing open to collect grime, dust and foreign particles.

LUBRICATION SCHEDULE

Always follow the bearing manufacturer's recommended lubrication schedule. If none is available use the following general schedule.

- a. Under average conditions where ambient temperatures do not exceed 120°F., lubrication is required 1 to 2 times a year.
- b. Under dirt laden atmosphere where there is a temperature range of 120°F to 150°F, lubrication is required from 3 to 6 times a year.
- c. Under extreme temperature conditions and extremely dirty atmospheres, lubrication should be scheduled at least once or twice a month.
- d. Belt driven units maximum temperature should not exceed 160°F. Direct driven models have temperature range stamped on motor.

Table 1: Recommended Lubricants

Manufacturer	Product	Temp. Range
BP	LG-#P-1	Below 32° F (0° C)
Gulf	Gulfcrown EP-1	
Imperial Oil	UnirexEP-1	
Shell	Alvania R-1	
BP	Energrease, MPMK11	32° F to 150° F (0° C to 66° C)
Gulf	Gulfcrown EP-2	
Imperial Oil	Unirex EP-2	
Shell	Alvania R-3	
Sun Oil	Sun Prestige 42	
Texaco	Regal AFB2	

MOTOR LUBRICATION

In general, standard motors are furnished with prelubricated, sealed-for-life ball bearings which require no lubrication for 7 to 10 years of normal service. Where motors have been ordered with greasable bearings, these bearings are factory lubricated and require no attention for one year under normal conditions. If grease relief fittings are provided, remove them when performing maintenance to allow grease to flow out. Whenever possible, apply grease while the motor is running. This practice should not supersede any safety considerations. **DO NOT OVER GREASE**, as most lubricants deteriorate motor windings, thereby reducing motor life and presenting a fire hazard.

Hidden Danger

In addition to the normal dangers of rotating machinery, fans present an additional hazard in their ability to suck in not only air, but loose material as well. Solid objects can pass through the fan and be discharged by the impeller as potentially dangerous projectiles. Therefore, screen intake to ductwork, whenever possible, to prevent the accidental entrance of solid objects. Never open access doors to a duct system with the fan running.

When starting the fan for the first time, completely inspect the ductwork and interior of the fan (with the power locked off), to make certain there is no foreign material which can be sucked into or blown through the ductwork.

Where the fan is accessible to untrained personnel or the general public, use maximum safety guards, even at the cost of some performance loss.

Fans may be connected directly to ductwork which will prevent contact with the internal moving parts, but when the inlet or outlet is exposed, install a suitable guard. PennBarry recommends the use of guards on all exposed non-ducted fans, ceiling and wall mounted.

CAUTION To reduce the risk of injury, install fan at least 7 feet above the floor if no guard is supplied.

Special Purpose Systems

Explosive, corrosive, high temperature, etc. may require special construction, inspection and maintenance. It is necessary to observe the fan manufacturer's recommendations and limitations concerning the type of material to be handled by the fan and its application to special conditions.

CAUTION Unprotected fans located less than 7' above the floor also require guarding as specified in the Occupational Safety and Health Act (OSHA).

Figure 9

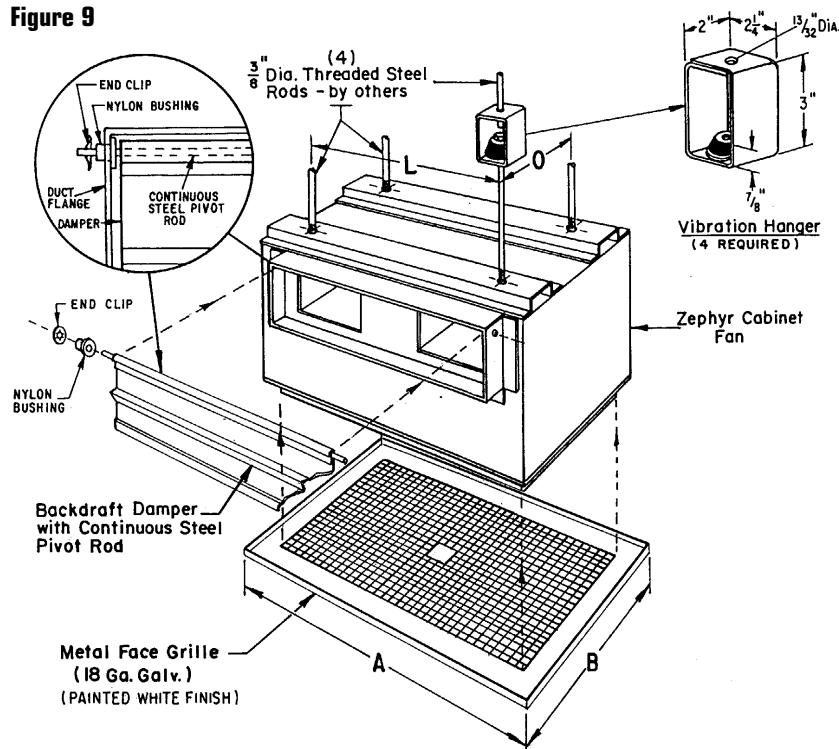

Table 3: Models Z14 & Z15 Metal Grill Dimensions

Model	Metal Face Grill		L	O
	A	B		
Z14	40 1/2	17	30 1/2	7 7/8
Z15	48	19	34 1/2	10

All dimensions are in inches.

Exploded View & Parts List

Parts Replacement

If replacing parts, do so with properly selected components which duplicate the original parts correctly. Incorrectly sized shafts, belts, pulleys, centrifugal wheels, etc. can damage the fan.

PARTS LIST

1. Mounting Rails
2. Roof Cap
3. Blower Mounting Brackets (Left & Right)
4. Blower Assembly
5. Access Door
6. Fan Cabinet
7. Motor
8. Motor Mounting Plate
9. Motor Pulley
10. Belt
11. Access Door
12. Fan Pulley
13. Outlet Guard
14. Inlet Guard

Figure 11

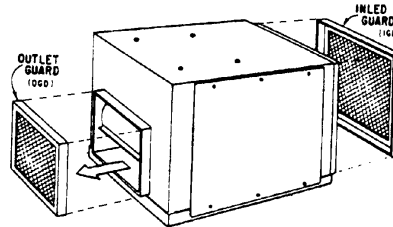
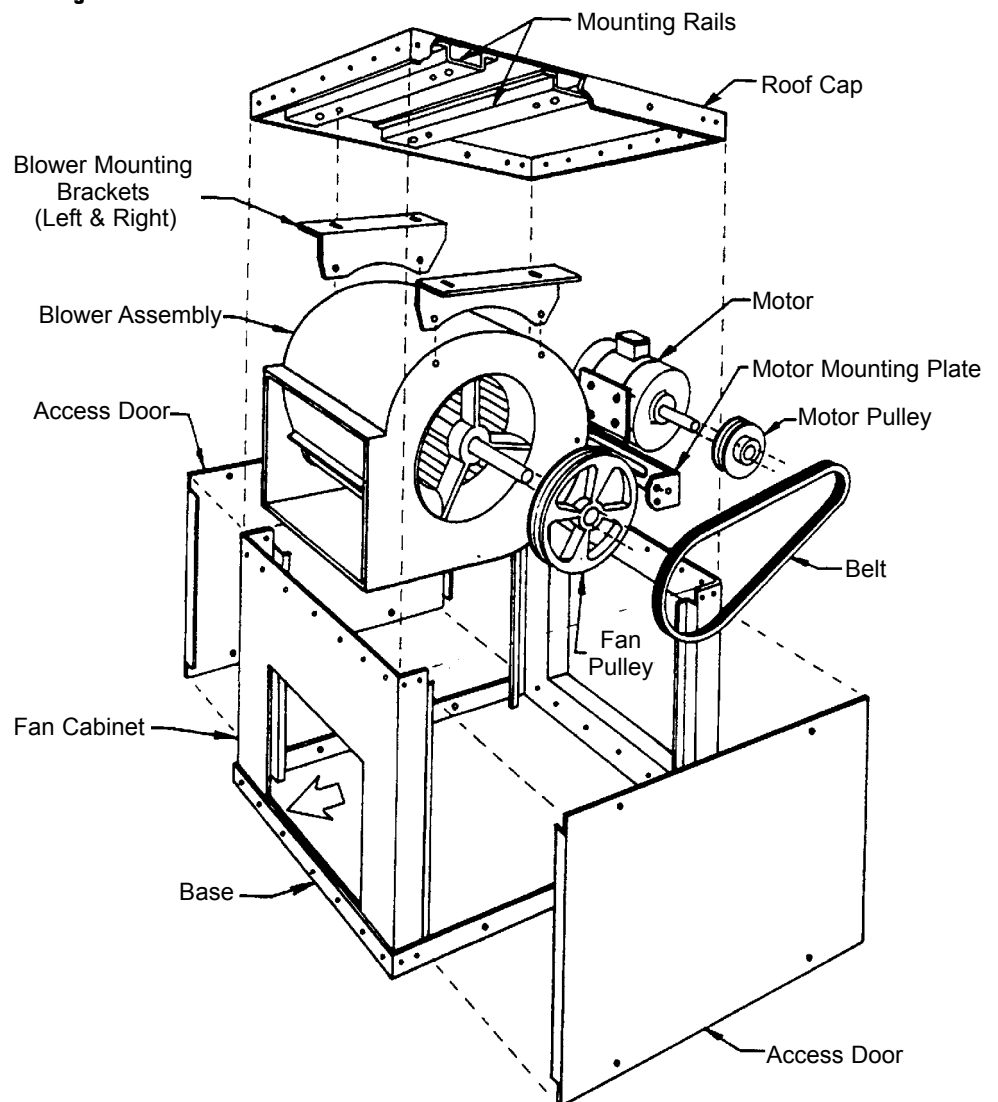

Figure 10



Troubleshooting Checklist

Symptom	Possible Cause(s)	Corrective Action
Excessive noise	<ol style="list-style-type: none"> 1. Defective or loose motor bearings 2. Ventilator base not securely anchored 3. Loose or unbalanced wheel/propeller 4. Misaligned pulleys or shaft 5. Loose or damaged wheel/propeller 6. Wheel running in wrong direction 	<ol style="list-style-type: none"> 1. Replace motor with same frame size, RPM, HP 2. Reset properly 3. Tighten screws, remove build-up, balance wheel/propeller 4. correct alignment 4. Replace wheel/propeller 6. Reverse direction
Fan inoperative	<ol style="list-style-type: none"> 1. Blown fuse or open circuit breaker 2. Loose or disconnected wiring 3. Defective motor 4. Broken belts 	<ol style="list-style-type: none"> 1. Replace fuses or circuit breaker 2. Shut off power and check wiring for proper connections 3. Repair or replace motor 4. Replace belts
Insufficient airflow	<ol style="list-style-type: none"> 1. Open access doors or loose sections of ducts 2. Clogged filters 3. Operation in wrong direction 4. Insufficient make-up air direction 	<ol style="list-style-type: none"> 1. Check for leakage 2. Clean filters 3. Correct rotation of wheel 4. Add make-up fan or louver opening
Water leaking into ductwork or collection of grease under fan	<ol style="list-style-type: none"> 1. Fan installed with slope in the wrong direction 2. Clogged drain spout 3. Cooling tube or motor dome top removed 4. Grease container full 	<ol style="list-style-type: none"> 1. Slope should be fitted in the direction of the drainage opening or grease collection box and drain spout 2. Clean drain spout 3. Install new cooling tube with gasket and dome top 4. Empty grease box
Motor overheating	<ol style="list-style-type: none"> 1. Overvoltage or under voltage 2. Operation in wrong direction 3. Fan speed too high 4. Incorrect motor (service factor 1.0, low ambient temperature) 5. Blocked cooling tube or leaky gasket 6. Undersized motor 	<ol style="list-style-type: none"> 1. Contact power supply company 2. Reverse direction of motor 3. Slow down fan by opening variable pitch pulley on motor shaft 4. Replace motor with correct open, NEMA service factors (1.15 or higher) with 40 degrees ambient 5. Remove blockage and seal cooling tube in place 6. Check motor ratings with catalog speed and air capacity chart

Note: Care should be taken to follow all local electrical, safety and building codes. Provisions of the National Electric Code (NEC), as well as the Occupational Safety and Health Act (OSHA) should be followed.

All motors are checked prior to shipment. If motor defects should develop, prompt service can be obtained from the nearest authorized service station of the motor manufacturer while under warranty. Exchange, repair or replacement will be provided on a no charge basis if the motor is defective within the warranty period. The PennBarry representative in your area will provide a name and address of an authorized service station if requested. **WARNING:** Motor guarantee is void unless overload protection is provided in motor wiring circuit.

Limited Warranty

What Products Are Covered

PennBarry Fans and Ventilators (each, a "PennBarry Product")

One Year Limited Warranty For PennBarry Products

PennBarry warrants to the original commercial purchaser that the PennBarry Products will be free from defects in material and workmanship for a period of one (1) year from the date of shipment.

Exclusive Remedy

PennBarry will, at its option, repair or replace (without removal or installation) the affected components of any defective PennBarry Product; repair or replace (without removal or installation) the entire defective PennBarry Product; or refund the invoice price of the PennBarry Product. In all cases, a reasonable time period must be allowed for warranty repairs to be completed.

What You Must Do

In order to make a claim under these warranties:

1. You must be the original commercial purchaser of the PennBarry Product.
2. You must promptly notify us, within the warranty period, of any defect and provide us with any substantiation that we may reasonably request.
3. The PennBarry Product must have been installed and maintained in accordance with good industry practice and any specific PennBarry recommendations.

Exclusions

These warranties do not cover defects caused by:

1. Improper design or operation of the system into which the PennBarry Product is incorporated.
2. Improper installation.
3. Accident, abuse or misuse.
4. Unreasonable use (including any use for non-commercial purposes, failure to provide reasonable and necessary maintenance as specified by PennBarry, misapplication and operation in excess of stated performance characteristics).
5. Components not manufactured by PennBarry.

Limitations

1. In all cases, PennBarry reserves the right to fully satisfy its obligations under the Limited Warranties by refunding the invoice price of the defective PennBarry Product (or, if the PennBarry Product has been discontinued, of the most nearly comparable current product).
2. PennBarry reserves the right to furnish a substitute or replacement component or product in the event a PennBarry Product or any component of the product is discontinued or otherwise unavailable.
3. PennBarry's only obligation with respect to components not manufactured by PennBarry shall be to pass through the warranty made by the manufacturer of the defective component.

General

The foregoing warranties are exclusive and in lieu of all other warranties except that of title, whether written, oral or implied, in fact or in law (including any warranty of merchantability or fitness for a particular purpose).

PennBarry hereby disclaims any liability for special, punitive, indirect, incidental or consequential damages, including without limitation lost profits or revenues, loss of use of equipment, cost of capital, cost of substitute products, facilities or services, downtime, shutdown or slowdown costs.

The remedies of the original commercial purchaser set forth herein are exclusive and the liability of PennBarry with respect to the PennBarry Products, whether in contract, tort, warranty, strict liability or other legal theory shall not exceed the invoice price charged by PennBarry to its customer for the affected PennBarry Product at the time the claim is made.

Inquiries regarding these warranties should be sent to: PennBarry, 1401 North Plano Road, Richardson, TX 75081.