

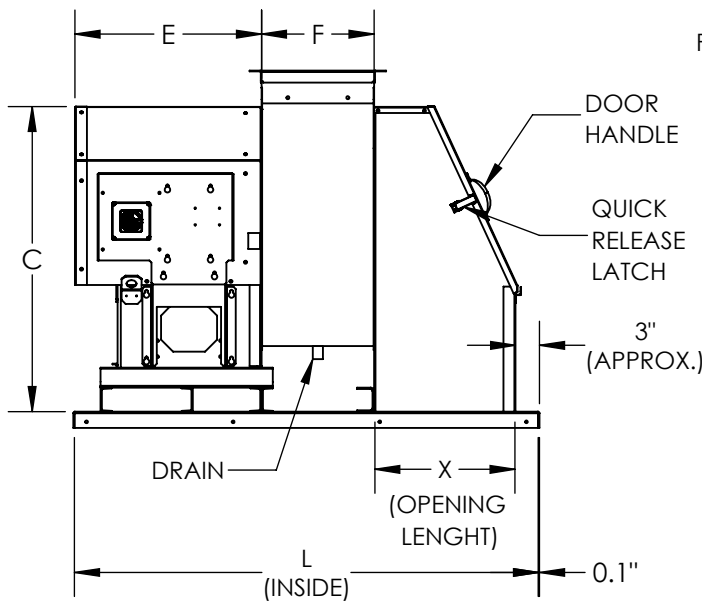

DATE: TAG:
 JOB:
 PROJECT:
 COMPANY:
 SALES PERSON:

UVS2, CLASS-2, ARRANGEMENT- 4
 INLET BOX AND CURB CAP FOR UL RESTAURANT GREASE EXHAUST (400F), SIZES 122-270



DRIVE SIDE VIEW

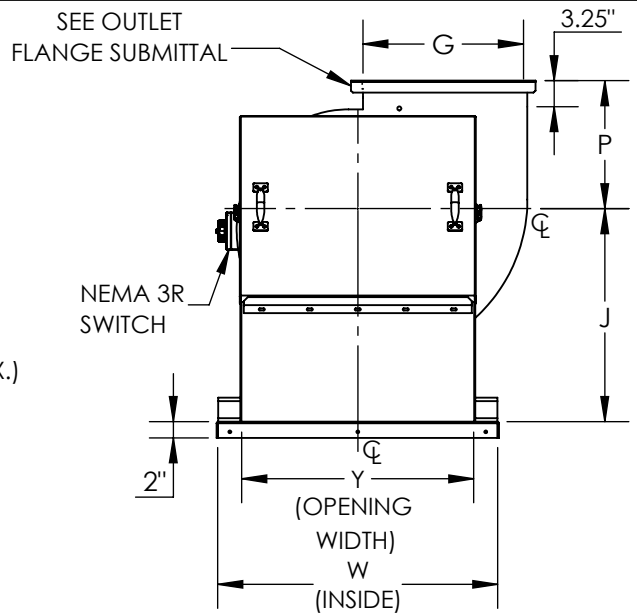

INLET VIEW

STANDARD CONSTRUCTION:

1. Discharge: UB
2. Rotation: CW/CCW (CW shown above)
3. Steel Wheel
4. Welded and Coated Housing and Pedestal
5. Welded and Coated Inlet Box and Curb Cap
6. Weather Cover
7. Access Door (Bolted or Hinged)
8. Housing Drain & Plug - 3/4" NPT
9. Pre-wired switch NEMA 3R
10. Flanged Outlet
11. Shaft Seal (Ceramic)
12. High Temperature Paint

OPTIONAL ACCESSORIES:

1. Speed Controllers (shipped loose only)
2. Grease Containment with optional Absorbent
3. Curb
4. Outlet Stack

DIMENSIONAL DATA

SIZE	C	E	"F" (WIDTH)										
			100%	95%	90%	85%	80%	75%	70%	65%	60%	55%	50%
122	29.38	18.75	9.88	9.75	9.56	9.44	9.25	9.06	-	-	-	-	-
135	30.25	18.75	10.88	10.75	10.56	10.38	10.19	10	9.81	-	-	-	-
150	32.63	18.75	12.06	11.88	11.69	11.5	11.31	11.06	10.88	10.69	10.5	-	-
165	35.13	23.31	13.25	13.06	12.81	12.63	12.44	12.19	11.94	11.75	11.5	11.31	-
182	38.13	23.31	14.06	13.88	13.63	13.38	13.09	12.88	12.63	12.38	12.13	11.88	11.63
200	41.50	23.31	15.38	15.13	14.88	14.63	14.38	14.13	13.88	13.5	13.25	13	12.75
222	45.06	23.31	17.13	16.88	16.63	16.25	16.00	15.75	15.38	15.13	14.75	14.5	14.13
245	48.50	25.75	18.75	18.50	18.13	17.88	17.50	17.13	16.88	16.5	16.13	15.88	15.63
270	52.63	28.63	20.63	20.38	20	19.63	19.38	18.88	18.5	18.13	17.75	17.38	17.13

DIMENSIONAL TABLE CONTINUED ON NEXT PAGE...

NOTES:

ALL DIMENSIONS ARE IN INCHES, WEIGHTS ARE APPROXIMATE AND DOES NOT INCLUDE DRIVES OR ACCESSORIES.

REVISION:	FORM:	REPLACES:
-----------	-------	-----------