

# UVS

Series 1 and 2

PRODUCT GUIDE

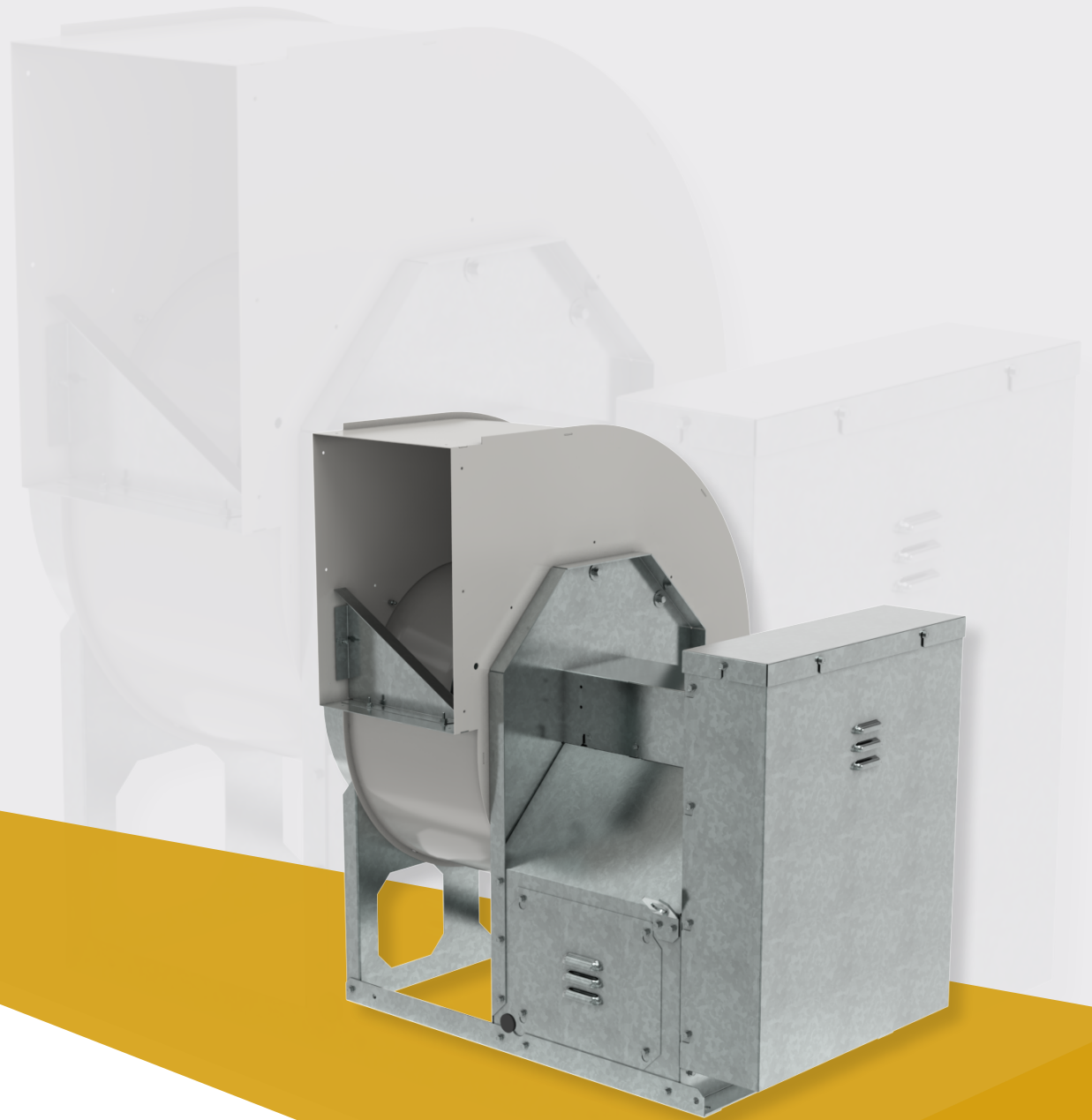

PENNBARRY™

PennBarry | Your Single Source for Commercial & Industrial Supply & Exhaust Fans | [www.pennbarry.com](http://www.pennbarry.com)

# TABLE OF CONTENTS

INTRODUCTION	3
CERTIFICATIONS	4
UVS WHEEL ADVANTAGE	5
FEATURES AND BENEFITS	6
OPTIONS & ACCESSORIES	7-8
FAN PACKAGES	9-10
CURB	11
DISCHARGE DAMPER DIMENSIONS	12-13
MOTOR AND VFD AVAILABILITY	14

# INTRODUCTION

## UVS

The Utility Vent Set (UVS) Housed Centrifugal Fans are SWSI, construction up to Class 2, Arrangement 4 and 10. The wide range of volume capacities of the UVS family make them excellent for use in hotels, office buildings, manufacturing plants, and hospitals. ECM, Permanent Magnet, and Premium Efficient Induction motors used with Speed Control Devices make it easy to adjust the airflow for the greatest comfort and efficiency.

At the heart of the UVS is a computer designed, backward inclined, centrifugal wheel. This non-overloading wheel assures low noise and high efficiency performance. The fan wheel, venturi inlet, housing, and frame are engineered to provide maximum performance and reliability. Fan housings utilize coated heavy-gauge materials employing welded construction.

A wide range of accessories are available to meet various application requirements. UVS Centrifugal Blowers are designed and built to provide the end user with a highly efficient and extremely reliable air moving unit. Each UVS is fully assembled, factory set at the specified RPM, and test run prior to shipment.

### UVS Direct Drive (Sizes 060-330)

- Static Pressure up to 12.5 in. w.g.
- Flow capacity up to 30,000 CFM.

### UVS Belt Drive (Sizes 060-542)

- Static Pressure up to 12.5 in. w.g.
- Flow capacity up to 63,000 CFM.

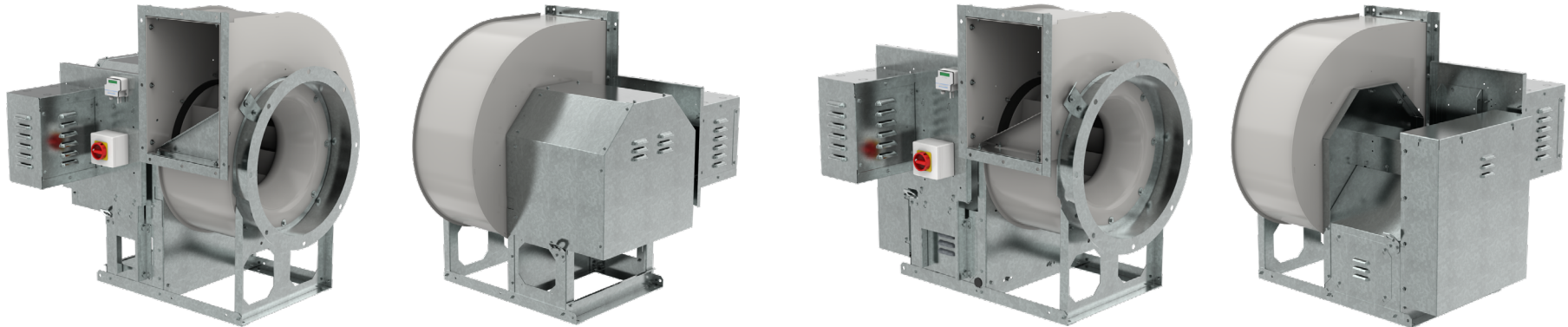

# CERTIFICATIONS

PennBarry utilizes AMCA and UL to certify fan performance, efficiency and ruggedness to meet the demands for a diverse range of applications.

## AMCA FEI SOUND & AIR

### AMCA Certified Rating Seal

PennBarry certifies that the UVS Fans shown herein are licensed to bear the AMCA seal. The ratings shown are based on tests and procedures performed in accordance with AMCA Publication 211 and AMCA Publication 311 and comply with the requirements of the AMCA Certified Ratings Program.



UVS2



UVS1

## UL 705 LISTED

### Power Ventilator

UVS Fans carry the UL label, 705 Power Ventilators (ZACT, ZACT7): File #E28413.



## UL SMOKE CONTROL

### Power Ventilator for Smoke Control Systems

UVS2 with Heat and Smoke application option carries the UL Power Ventilators for Smoke Control System label, (ZAXH/ZAXH7), file #MH19473

Rated for:

- 500F 4-hrs
- 572F 2-hrs
- 752F 2-hrs
- 1000F 1-hr



### Requirements

- Requires steel wheel, weather cover, motor heat shield, flanged inlet, ceramic shaft seal, class F minimum motor insulation.
- Belt drive requires shaft cooler.

## UL RESTAURANT EXHAUST LISTED

### Power Ventilator for Restaurant Exhaust Appliances

UVS2 with Grease Application option carries the UL Power Ventilators for Restaurant Exhaust label, UL762 (YZHW/YZHW7), file #MH10684

**Max. Temp. 400°F**

UVS2 Direct Drive

**Max. Temp. 500°F**

UVS2 Belt Drive



### Requirements

- Requires steel wheel, drain, access door, flanged inlet/outlet, high temperature paint, ceramic shaft seal, NEMA 3R switch.
- Belt drives requires shaft cooler.
- Direct Drive requires class F insulation as a minimum.
- Outdoor applications for belt drive must be supplied with a weather cover.

# UVS WHEEL ADVANTAGE

At the heart of the UVS is a computer designed, backward inclined, centrifugal wheel. These non-overloading wheels assure low noise and high efficiency performance. The fan wheel, venturi inlet, housing, and frame are engineered to provide maximum performance and reliability. Before leaving the plant, each fan is carefully subjected to a test at the field operating rpm. Dynamic balancing is performed by experienced personnel using electronic equipment to ensure smooth and trouble-free operation.

UVS includes two wheels, the variations of wheels and partial width combine to broaden the performance range and to meet higher efficiency demands.



## UVS1

Riveted aluminum wheel with weld between backward inclined flat blades and shroud.



## UVS2

Welded aluminum or steel wheel with backward inclined flat blades. Available in partial widths.

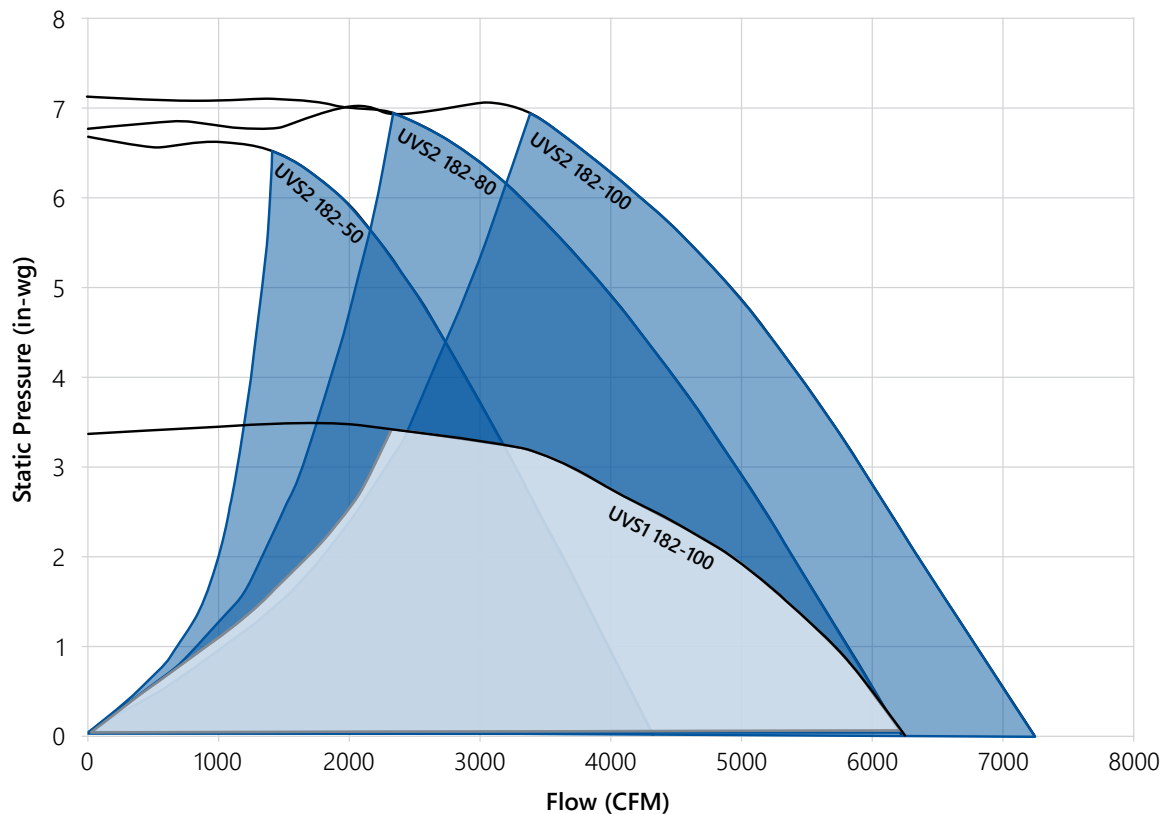

Example shown for the size 182, the performance provides a broad range to promote additional options.

- Series 1 meets Class 0.
- Series 2 meets Class 0, 1, 2.

# FEATURES AND BENEFITS

## BEARING LIFE

Bearings are sized for a minimum L10 life exceeding 80,000 (UVS2) and 100,000 (UVS1) hours of operation. They require no maintenance other than periodic lubrication. Standard Zerk lube fittings allow for ease of lubrication.

## SOLID STEEL SHAFTS

Sized to withstand a minimum of 125% of maximum catalogued operating speed, shafts are precision ground, polished, and treated for rust resistance.

## DURABLE WELDED HOUSING

UVS blowers are manufactured of welded coated mild steel for strength and durability.

## VERSATILE OPERATION

All unit sizes are field rotatable to various discharge positions. Both clockwise and counter-clockwise rotations are available. See page 15 for limits.

## MOTORS AND DRIVES

Preset at factory. V-belt drives are set to at least 150% of driven HP. Offering Induction, Permanent Magnet (PM), and Electronically Commutated (ECM) motor solutions. See page 14 for additional details of the Motor and VFD solutions.

## INTEGRAL LIFTING LUGS

All units are furnished with lifting lugs integrated into the inlet cover and drive pedestal.

## HEAVY DUTY SUPPORT FRAME

The heavy duty support frame provides a strong structural foundation for the motor and drive assembly, as well as rigidity to support the housing.

## STANDARD GASKETED ACCESS DOOR

The standard gasketed and bolted access door enables easy maintenance of internal components.

## BACKWARD INCLINED WHEEL

UVS ventilators use PennBarry's computer designed wheel. They are backward inclined and non-overloading, using high strength aluminum or steel construction. All UVS wheel designs provide a high level of static efficiency while reducing start-up torque, thus extending drive component life. All wheels are statically and dynamically balanced for quieter operation.

## SLIP FIT INLET AND OUTLET

Some applications for Housed Centrifugal Fans call for the use of flexible connectors. The UVS is supplied with a slip fit inlet and outlet as standard. This reduces the total fan length and the cost for slip connections.

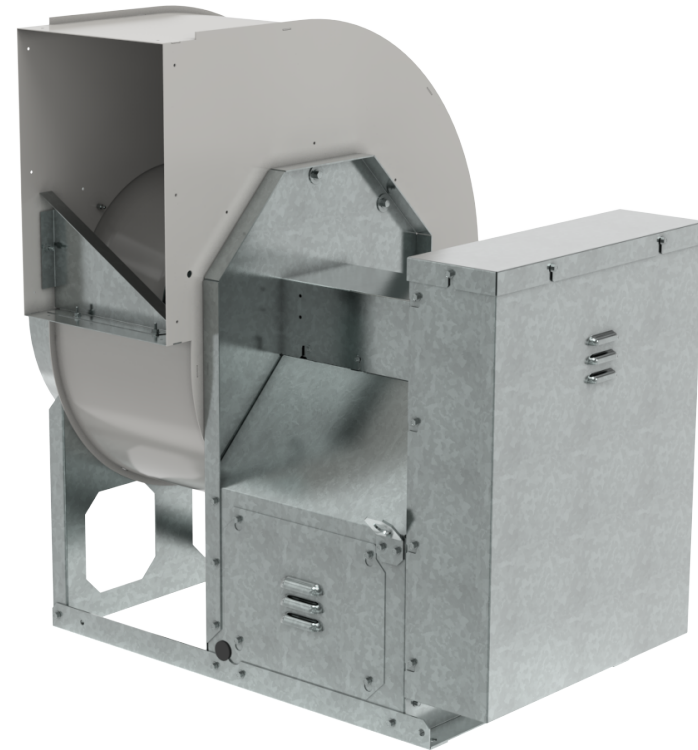

# OPTIONS & ACCESSORIES

## EXTENDED LIFE BEARINGS

L10-200K Bearings (for UVS1 only).

## COATINGS

The fan housing is available with Air Dry Enamel (Standard on the UVS), with options for Air Dry Epoxy, Air Dry Phenolic Epoxy, Air Dry Epoxy with UV Topcoat, and Air Dry Phenolic Epoxy with UV Topcoat. All coating options come standard in Gray color, see Colors and Coatings brochure for additional options.

## BACKDRAFT DAMPER

Galvanized construction with single rear flange. Spring assist, parallel bladed.

## CONTROL DAMPER

Low leakage aluminum or galvanized construction with double punched flanges. Blades are opposed and airfoil shape. Actuators for control damper are spring return (fail open), NEMA 2, on/off (non-modulating) available for AC/DC 24V and AC 120V or 230V options. End Switch is integral to Damper Actuators.

## DISCONNECT SAFETY SWITCHES

NEMA1 and NEMA3R. Switches in housings are available to turn fans on and off for service only. Switches are non-fused rotary type. Field wiring is required.

## INTERNAL WIRING

NEMA1 and NEMA3R for internal wiring of electrical components.

## STAINLESS STEEL SHAFTS

Available on belt drive units as option for corrosion resistant shafts.

## DRAIN CONNECTIONS

3/4 inch NPT connection always at the lowest point of the housing.

## EXTENDED LUBE LINES

Preloaded at the factory, lube lines allow bearing maintenance when a weather cover is installed or when easy access to the bearings is unavailable.

## EC MOTOR CONTROLLER OPTIONS

Onboard Potentiometer and 0-10 VDC Remote Output  
iQ Controllers available  
0-10 VDC BMS Wire Harness

## VARIABLE FREQUENCY DRIVES

Variable frequency drives (VFDs) are designed to meet performance requirements while increasing efficiency. By varying the fan motor input frequency and voltage, the VFD controls the motor speed and torque, helping to improve productivity and lower energy consumption. Available Mounted (indoor applications only), or shipped loose and separately.

## SHAFT GROUNDING

When Induction (Totally Enclosed and Open Drip Proof) motors are used with VFDs, Shaft Grounding can be added to the motor so to help protect the bearings against shaft currents.

## HEIGHT SAVING ISOLATION RAILS

Constructed of high strength steel and used with spring isolators.

## VIBRATION ISOLATORS

Rubber-In-Shear Floor Mounted - used for higher operating speeds (FRPM > 1500), indoors, on a flat surface, for fans with smaller wheels < 30 inch diameter), and no adjustment needed.

Spring Floor Mounted -Typically used on 400 FRPM to 1500 FRPM, indoors, on flat surface, fans with larger wheels(> 30 inch diameter). Below 400 FRPM, 2 inch deflection is recommended.

Housed Spring Floor Mounted - Similar to Spring Floor applications, but reducing lateral force effects.

Spring Restrained Isolators - Similar to Spring Floor application, but for use in outdoor applications especially where wind loading is a concern.

## SPARK RESISTANT CONSTRUCTION

Series 2 is available in type A, B, or C, while Series 1 is limited to type B. Construction adheres to the guidelines defined by AMCA 99.

## INLET/OUTLET GUARDS

Inlet and Outlet Guards provide safety in non-ducted installations. Inlet Guards are constructed of heavy gauge steel wire, and expanded steel metal for Outlet Guards. Both are easily removeable for maintenance personnel cleaning or inspection.

# OPTIONS & ACCESSORIES

## **FLEXIBLE DUCT CONNECTORS**

Used as an alternative to rigid connections. These duct connectors are highly recommended since they reduce vibration transmission through the duct work. Available for both indoor and outdoor installations. Outdoor connectors contain UV protection suitable for that environment.

## **WEATHER COVER**

The weather cover protects the drive components from weather and other detrimental conditions. Steel covers are easily removed and reinstalled with typical mechanical fasteners. Cover also acts as a guard to protect personnel and drive assemblies. Tamper proof hardware is available to provide an extra layer of safety to minimize unauthorized access.

## **SHAFT GUARD**

Galvanized steel cover over the shaft to help protect against accidental exposure while the fan is running. Included as part of weather cover. Two piece assembly for ease of assembly. Meets OSHA requirements.

## **BELT GUARD**

Galvanized steel cover over the belts and pulleys to help protect against accidental exposure while the fan is running. Removeable top and front cover for quick inspection. Included as part of weather cover. Meets OSHA requirements.

## **FLANGES**

Punched Flanges and Companion flanges are available for Inlet and Outlet. Galvanized steel construction is standard. UVS2 is available for coated continuous welded Inlet/Outlet Flanges.

Flanges facilitate the connection of duct work and discharge dampers. Companion flanges are also available when the UVS is connected to duct work by a transition section. The companion flange fits the fan to the transition and allowing for proper sizing.

## **ACCESS DOORS**

A hinge door option is available as an accessory from the standard bolted access door.

## **SHAFT SEAL**

Neoprene and Ceramic shaft seals with aluminum retainer plates are available where the shaft penetrates the fan housing. Seals are secured in place by fastening an aluminum retainer plate to housing.

## **AUTOMATIC BELT TENSIONER**

Belt tensioner increases life of the belts by maintaining proper tension thus reducing manual maintenance to tension belts. Tensioners are available up to 10-hp motors and are not available on Life Safety applications.

## **PIEZOMETER RING**

Piezometer Ring measures the pressure differential across the fan inlet which can be converted to an airflow measurement. An optional transducer (w/ readout) is available, along with the option to mount the transducer and transformer to power (24V) transducer.

## **HEAT SLINGER**

For elevated temperatures on belt driven fans, heat slingers are required to cool down bearings.

## **CURB CAP AND INLET BOX**

See page 9 for details.

## **ROOF CURB**

See page 11 for details.

## **DISCHARGE STACK**

See page 10 for details.

## **GREASE TRAP**

See page 9 for details.

## **DUCT DROP FOR CURB**

Welded steel and coated. Divider for duct to be galvanized and not coated. Intended to be assembled with vented curb to allow for cooling of duct. See page 11 for example.

# FAN PACKAGES

## CURB CAP AND INLET BOX

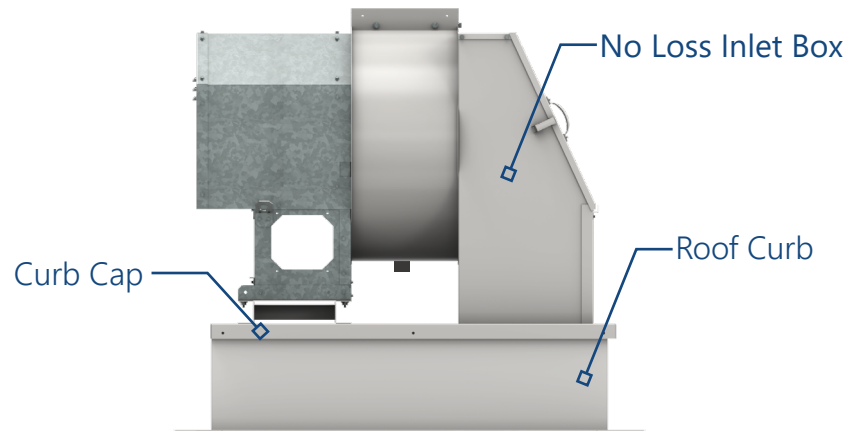

## BENEFITS

- The inlet box is designed to have less than 1% impact on performance
- All UVS2 models are available with integral curb cap and inlet box. (Sizes 60-270) Contact factory for availability of larger sizes
- Large gasketed access doors utilizing quick release latches for quick inspection.
- Fully welded box to minimize leakage.
- Configurable roof curbs

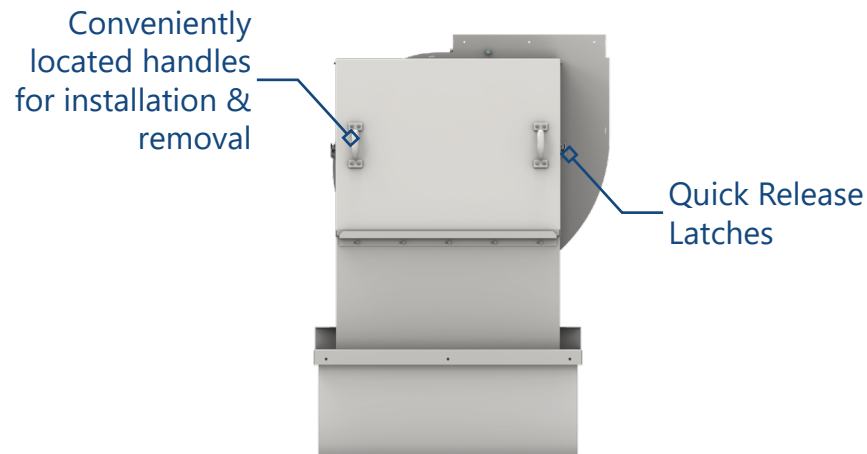

## GREASE CONTAINMENT BOX

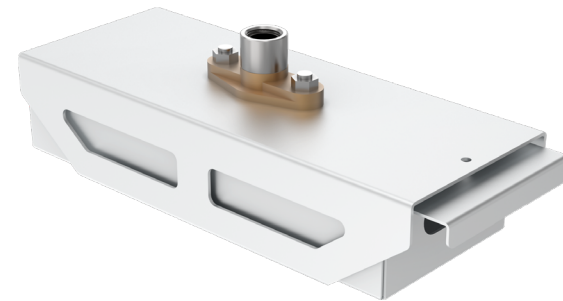

- Aluminum construction.
- Containment box slides out from sleeve for ease of maintenance.
- Sleeve is coupled direct to housing drain.
- Optional 3M absorbent sock available.

# FAN PACKAGES

## STACK EXTENSION

PennBarry can provide a pre-engineered stack to extend the UVS discharge to 10ft. Preventing contaminated air from re-entering the ventilation system.

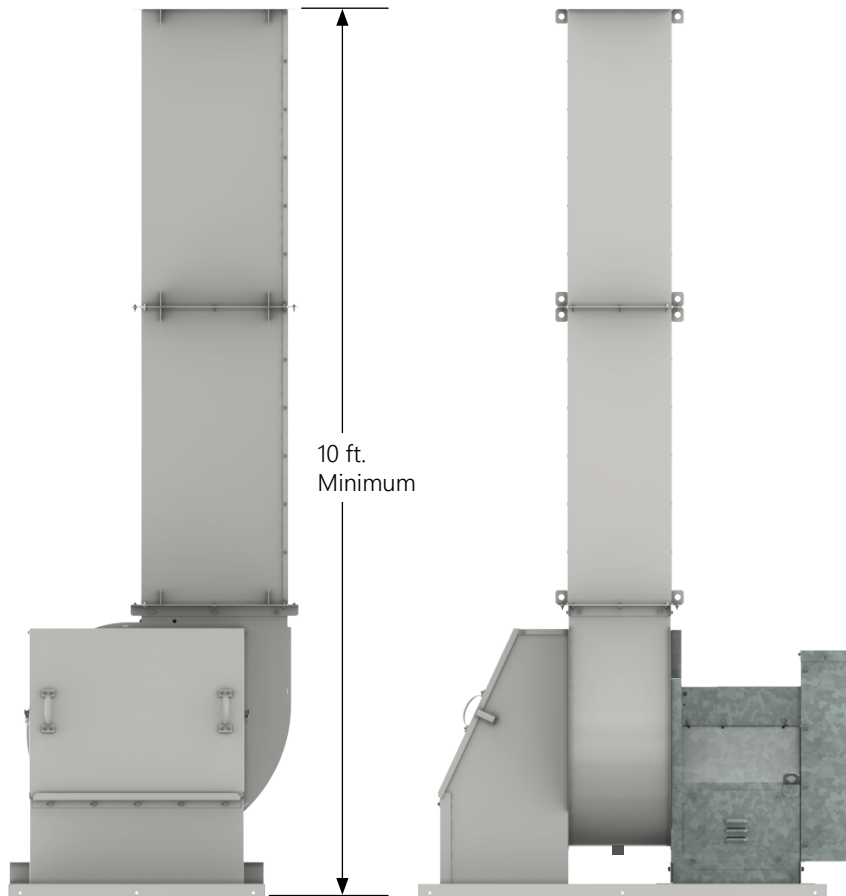

## BENEFITS

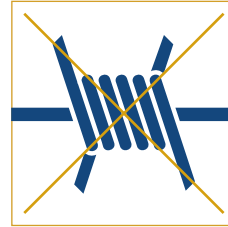

Rated up to 125 mph without guy wires when used with Curb Cap and Inlet Box. Otherwise guy wires needed.

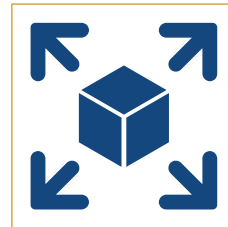

Available for both UVS1 and UVS2 for sizes 60 to 542.

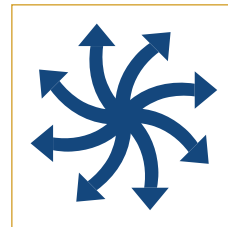

Versatile with/without curb cap and inlet box. Direct drive or belt drive.

# CURB

## CURB AND DUCT DROP

## BENEFITS

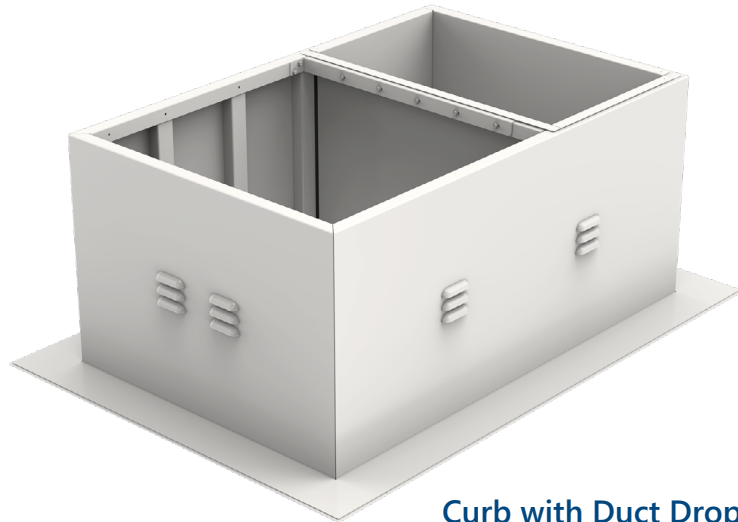

Curb with Duct Drop

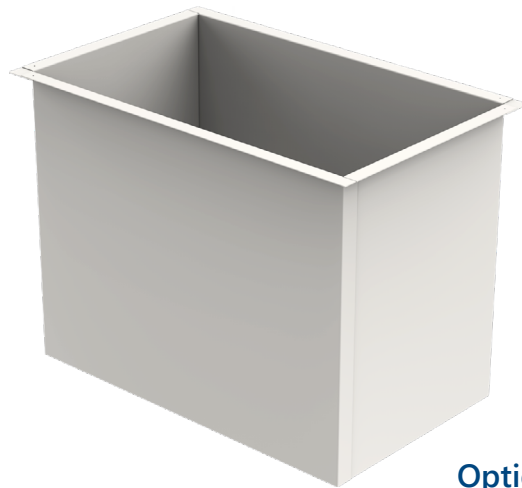

Optional Duct Drop

### STANDARD CONSTRUCTION

- Coated steel exterior
- Heavy Duty Welded construction
- Various heights of 12, 14, 16, 18, 24
- Suitable for temperatures up to 500F

### VENTED (OPTIONAL)

- Suitable for high temperature and Smoke Controls

### LINER AND INSULATED (OPTIONAL)

- Stainless steel lined and insulated

### DUCT DROP (OPTIONAL)

- Length to be equal to or greater than curb height
- Coated and fully welded steel construction
- Paired with vented curb to allow for cooling
- Drop sits on top lip of curb
- Bolted cross brace provided for support

### GASKET

- Silicone or Neoprene based on temperature

# DISCHARGE DAMPER DIMENSIONS

## UTILITY VENT SET FAN UVS1, CONTROL DAMPER

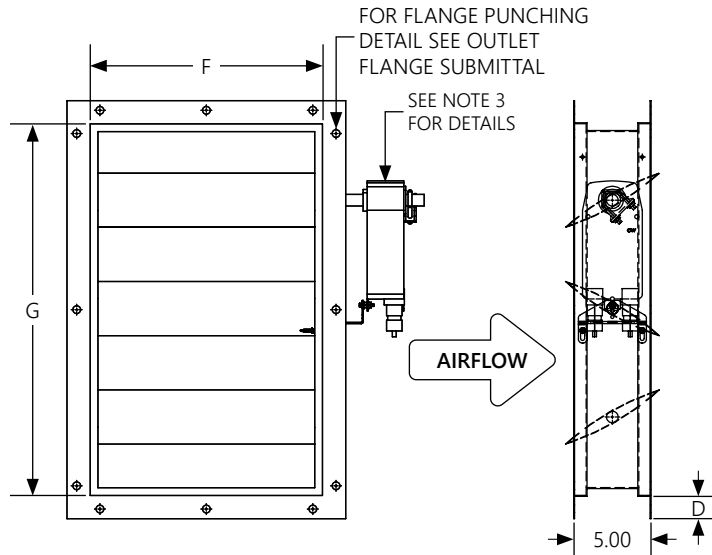

BACK VIEW  
(BLADES OPEN)

SIDE VIEW  
(BLADES OPEN)

Model Sizes	F	G
060	7.06	10.00
070	7.06	10.00
080	7.06	10.00
100	7.06	10.00
122	8.63	12.25
135	9.50	13.50
150	10.56	15.00
165	11.63	16.50
182	12.88	18.25
200	14.13	20.00
222	15.69	22.25
245	17.25	24.50
270	19.06	27.00
300	21.19	30.00
330	23.25	33.00
365	25.75	36.50
402	28.38	40.25
445	31.38	44.50
490	34.50	49.00
542	38.25	54.25

NOTES :

1. Control Damper to be double flanged, punched, and opposed airfoil bladed.
2. Galvanized construction.
3. NEMA 2, Spring Return Actuator, Fail Open, Non-modulating, 2 SPDT Auxiliary Limit Switch, available in 24V, 115V, or 230V.
4. For smaller sizes, actuator may be extended below fan.
5. Shipped Loose.

## UTILITY VENT SET FAN UVS1, BACKDRAFT DAMPER

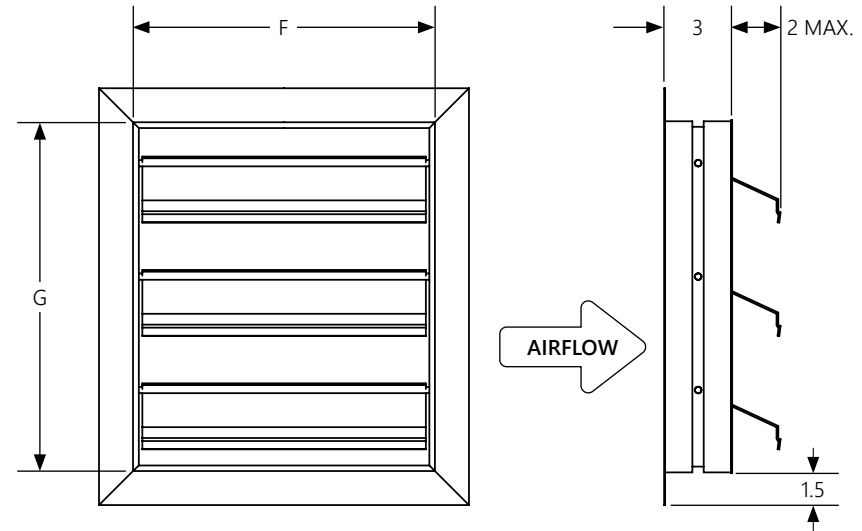

BACK VIEW  
(BLADES OPEN)

SIDE VIEW  
(BLADES OPEN)

Model Sizes	F	G
060	7.06	10.00
070	7.06	10.00
080	7.06	10.00
100	7.06	10.00
122	8.63	12.25
135	9.50	13.50
150	10.56	15.00
165	11.63	16.50
182	12.88	18.25
200	14.13	20.00
222	15.69	22.25
245	17.25	24.50
270	19.06	27.00
300	21.19	30.00
330	23.25	33.00
365	25.75	36.50
402	28.38	40.25
445	31.38	44.50
490	34.50	49.00
542	38.25	54.25

NOTES :

1. Backdraft Damper to be single flanged and parallel bladed.
2. Galvanized construction.
3. Shipped Loose.
4. Dampers will include Spring Assist.

# DISCHARGE DAMPER DIMENSIONS

## UTILITY VENT SET FAN UVS2, CONTROL DAMPER

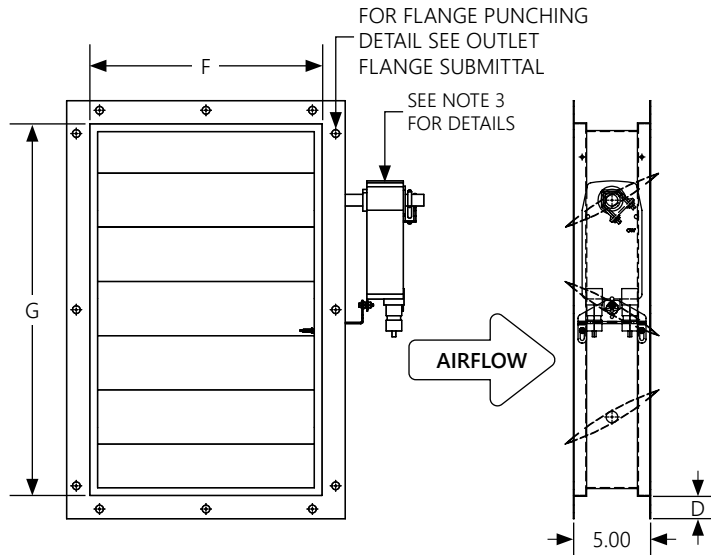

BACK VIEW  
(BLADES OPEN)

SIDE VIEW  
(BLADES OPEN)

Model Sizes	D	F (100% W)	F (80% W)	F (50% W)	G
060	1.5	8.19	-	-	11.56
070	1.5	8.19	-	-	11.56
080	1.5	8.19	-	-	11.56
105	1.5	8.19	-	-	11.56
122	1.5	9.88	9.25	-	13.06
135	1.5	10.88	10.19	-	14.38
150	1.5	12.06	11.31	-	15.88
165	1.5	13.25	12.44	-	17.56
182	1.5	14.06	13.09	11.63	20.06
200	1.75	15.38	14.38	12.75	22.00
222	1.75	17.13	16.00	14.13	24.50
245	1.75	18.75	17.50	15.63	27.00
270	1.75	20.63	19.38	17.13	29.75
300	1.75	23.00	21.50	19.13	32.88
330	1.75	25.25	23.63	21.00	36.19
365	1.75	27.88	26.13	23.25	40.06
402	2.00	30.75	28.88	25.63	44.13
445	2.00	34.00	31.88	28.25	48.75
490	2.00	37.50	35.13	31.13	53.50
542	2.00	41.50	38.88	34.50	59.19

NOTES :

- Control Damper to be double flanged, punched, and opposed airfoil bladed.
- Galvanized or extruded Aluminum construction.
- NEMA 2, Spring Return Actuator, Fail Open, Non-modulating, 2 SPDT Auxiliary Limit Switch, available in 24V, 115V, or 230V.
- For smaller sizes, actuator may be extended below damper.
- Shipped loose.

## UTILITY VENT SET FAN UVS2, BACKDRAFT DAMPER

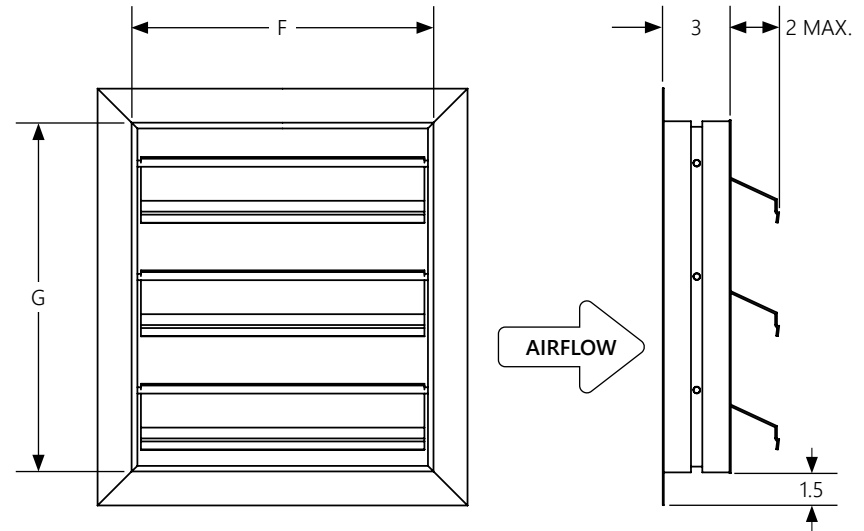

BACK VIEW  
(BLADES OPEN)

SIDE VIEW  
(BLADES OPEN)

Model Sizes	F (100% W)	F (80% W)	F (50% W)	G
060	8.19	-	-	11.56
070	8.19	-	-	11.56
080	8.19	-	-	11.56
105	8.19	-	-	11.56
122	9.88	9.25	-	13.06
135	10.88	10.19	-	14.38
150	12.06	11.31	-	15.88
165	13.25	12.44	-	17.56
182	14.06	13.09	11.63	20.06
200	15.38	14.38	12.75	22.00
222	17.13	16.00	14.13	24.50
245	18.75	17.50	15.63	27.00
270	20.63	19.38	17.13	29.75
300	23.00	21.50	19.13	32.88
330	25.25	23.63	21.00	36.19
365	27.88	26.13	23.25	40.06
402	30.75	28.88	25.63	44.13
445	34.00	31.88	28.25	48.75
490	37.50	35.13	31.13	53.50
542	41.50	38.88	34.50	59.19

NOTES :

- Backdraft Damper to be single flanged and parallel bladed.
- Galvanized construction.
- Shipped loose.
- Dampers will include Spring Assist.

# MOTOR AND VFD AVAILABILITY\*

Unit Size	ECM Motor		PM Motor		Induction Motor	
	Motor HP Range - 1/6 hp to 3/4 hp		Motor HP Range - 1/2 hp to 30 hp		Motor HP Range - 1/4 hp to 60 hp	
	Motor RPM Range - 500 to 1725		Motor RPM Range - 350 to 2160		Motor Rpm Range - 900, 1200, 1800, 3600 (750, 1000, 1500, 3000 50 hz)	
	Motor Enclosure - OPAO		Motor Enclosure - TENV < 2 hp < TEFC		Motor Enclosure - ODP, TEFC, EXP	
	Phase-Voltages - 115V/230V/277V		Phase-Voltages - 3-ph: 230/460 (380-480)		Phase-Voltages - 1-ph: 115/230, 3-ph: 230/460 (380-480) (50hz)	
	Direct Drive	Belt Drive	Direct Drive w/ VFD	Belt Drive w/ VFD	Direct Drive w/ or w/o VFD	Belt Drive w/ or w/o VFD
60	X	N/A	1	X	X	X
70	X	N/A	1	X	X	X
80	X	N/A	1	X	X	X
105	X	N/A	1	X	X	X
122	X	N/A	X	X	X	X
135	X	N/A	X	X	X	X
150	X	N/A	X	X	X	X
165	N/A	N/A	X	X	X	X
182	N/A	N/A	X	X	X	X
200	N/A	N/A	X	X	X	X
222	N/A	N/A	X	X	X	X
245	N/A	N/A	X	X	X	X
270	N/A	N/A	X	X	X	X
300	N/A	N/A	2	X	2	X
330	N/A	N/A	2	X	2	X
365	N/A	N/A	N/A	X	N/A	X
402	N/A	N/A	N/A	X	N/A	X
445	N/A	N/A	N/A	X	N/A	X
490	N/A	N/A	N/A	X	N/A	X
542	N/A	N/A	N/A	X	N/A	X

NOTE: N/A = Not Available, X = Available, 1 = UVS1 Only, 2 = UVS2 Only

\*-If VFD will be used with a fan mounted outdoors, it is recommended VFD be installed indoors (by others), or a weather resistant enclosure (enclosure and mounting, by others.)



# PENNBARRY PRODUCT SOLUTIONS



## Commercial

- Roof & wall exhaust centrifugal fans
- Ceiling, wall, & inline centrifugal fans
- Roof supply centrifugal fans
- Square & round centrifugal fans
- Wall mounted axial fans
- Hooded roof axial fans
- Upblast roof axial fans
- Gravity ventilators
- Roof curbs



## Industrial

- Freestanding centrifugal fans
- Industrial & material handling fans
- Tubular centrifugal inline fans
- Mixed flow centrifugal fans
- Plenum fans
- Wall mounted propeller fans
- Tube axial fans
- Vane axial fans
- Lab exhaust



## Kitchen ventilation

- Exhaust fans

PennBarry is proud to be your preferred manufacturer of commercial and industrial fans and blowers. Learn how PennBarry can assist you in your next application by contacting your PennBarry Representative or visiting us on the web at [www.pennbarry.com](http://www.pennbarry.com)

PennBarry | [www.pennbarry.com](http://www.pennbarry.com) | [pbtsr@pennbarry.com](mailto:pbtsr@pennbarry.com) | Tel 765 483 5860

PennBarry reserves the right to make changes at any time, without notice, to models, construction, specifications, options and availability. This document illustrates the appearance of PennBarry products at the time of publication. View the latest updates on the PennBarry website.

© 2022 PennBarry. All rights reserved. UVS JUNE 2025.



PENNBARRY™