

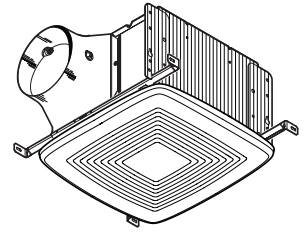

PENNBARRY™

# SPECIFICATION SHEET

## MODEL ZQ165 VENTILATION FAN



### FEATURES

#### BLOWER:

- Plug-in, permanently lubricated motor - engineered for continuous operation
- Dynamically balanced centrifugal blower wheel for quiet, efficient performance
- Low RPM for quiet operation
- Airflow-smoothing baffles reduce turbulence

#### HOUSING:

- Rugged, galvanized steel construction
- 6" round duct connector with tapered sleeve and no metallic clatter
- 7-5/8" height allows for 2" x 8" ceiling installations
- Sturdy, easy, four-point mounting directly to joist
- Includes unique, patented spacer for mounting to engineered "I" joists
- Includes hanger bars to position housing anywhere between 16" to 24"-on-center joists
- Can be mounted in ceilings up to 12/12 pitch

#### GRILLE:

- Polymeric construction
- Innovative design - the result of extensive research with designers and consumers

#### CONTROLS (Purchase separately):

- Refer to PennBarry's catalog for a complete line of accessories to effectively adapt these fans to your construction requirements.

U.L. Listed for use over bathtubs and showers when connected to a GFCI protected branch circuit (ceiling mount only).

### DIMENSIONS

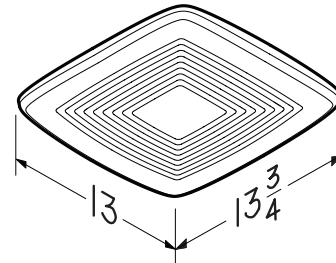
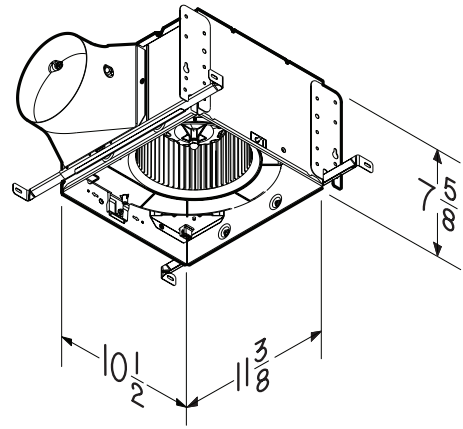

PennBarry | 605 Shiloh Rd. Plano, TX 75074 | 1 972-212-4700 | www.pennbarry.com

| REFERENCE | QTY. | REMARKS | Project      |           |
|-----------|------|---------|--------------|-----------|
|           |      |         | Location     | Architect |
|           |      |         | Engineer     |           |
|           |      |         | Contractor   |           |
|           |      |         | Submitted by | Date      |

# PERFORMANCE RATINGS

## MODEL ZQ165 FAN

### AMCA PERFORMANCE

| Model | Static Pressure (Ps) | CFM | Sones | Fan Watts |
|-------|----------------------|-----|-------|-----------|
| ZQ165 | 0.10                 | 150 | 1.4   | 42.8      |
|       | 0.25                 | 120 |       |           |

### AMPS

| Model | Amps |
|-------|------|
| ZQ165 | 0.5  |

### WEIGHT

| Model | Shipping Weight |
|-------|-----------------|
| ZQ165 | 13.1 lbs        |



### AIR FLOW PERFORMANCE

