

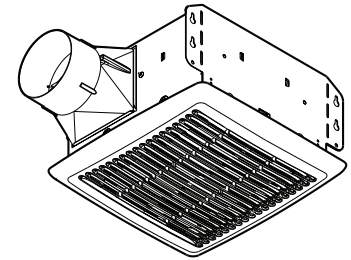

# MODEL ZQ75 VENTILATION FAN



**DESCRIPTION**

**BLOWER:**

- Plug-in, permanently lubricated motor - engineered for continuous operation
- Dynamically balanced centrifugal blower wheel for quiet, efficient performance
- Low RPM for quiet operation

**HOUSING:**

- Rugged, 26 gauge, galvanized steel construction
- Polymeric, 4" duct connector with tapered sleeve and no metallic clatter
- 5-3/4" height allows for 2" x 6" ceiling installations
- Sturdy, easy, four-point mounting directly to joist
- Can be mounted in ceilings up to 7/12 pitch
- Can be installed in a wall if mounted 8-ft. or more above the floor

**GRILLE:**

- Polymeric construction
- Innovative design - the result of extensive research with designers and consumers

**CONTROLS (Purchase separately):**

- Refer to PennBarry's catalog for a complete line of accessories to effectively adapt these fans to your construction requirements.

cULus Listed for use over bathtubs and showers when connected to a GFCI protected branch circuit (ceiling mount only).

cULus Listed for use in insulated ceilings (TYPE I.C.)

**TYPICAL SPECIFICATION**

Fan shall be PennBarry Model ZQ75.

Fan shall have corrosion resistant galvanized steel housing with four-point mounting capability. It shall be ducted to a roof or wall cap using 4" round ductwork.

Blower assembly shall be removable, have a centrifugal-type blower wheel and a permanently lubricated motor designed for continuous operation.

Non-metallic damper/duct connector shall be included.

Air delivery shall be no less than the airflow values and no greater than the sound level values listed.

Ceiling Ventilator shall be cULus Listed for use in insulated ceilings (Type I.C.) and for use over bathtubs and showers when connected to a GFCI protected branch circuit.



PennBarry | 605 Shiloh Rd. | Plano, TX 75074 | 972.212.4700 | www.pennbarry.com

REFERENCE	QTY.	REMARKS	Project	
			Location	
			Architect	
			Engineer	
			Contractor	
			Submitted by	Date

# PERFORMANCE RATINGS

## MODEL ZQ75 VENTILATION FAN

### AMCA LICENSED PERFORMANCE

Model No.	Duct Size	Performance @ Static Pressure (Ps) - Inches Water Gage										Volts	Hz.	Nominal RPM	
		0.000" Ps		0.100" Ps			0.125" Ps		0.250" Ps		0.375" Ps				
		CFM	Sones	CFM	Sones	Watts	CFM	Sones	CFM	Sones	CFM				Sones
ZQ75	4" Round	87	1.0	76	1.5	26	72	1.5	56	2.5	38	3.0	120	60.0	840



Performance ratings include the effects of inlet grille and backdraft damper. Speed (RPM) shown is nominal. Performance is based on actual speed of test. The sound ratings are loudness values in fan sones at 5' (1.5m) in a spherical free field calculated per AMCA Std. 301. Values shown are for Installation Type B: free inlet hemispherical sone levels. Performance certified is for Installation Type B: Free inlet, Ducted outlet.

### ELECTRICAL & WEIGHT

Model	Volts	Hz	Amps	Shipping Weight
ZQ75	120	60	0.3	10.0

### DIMENSIONS

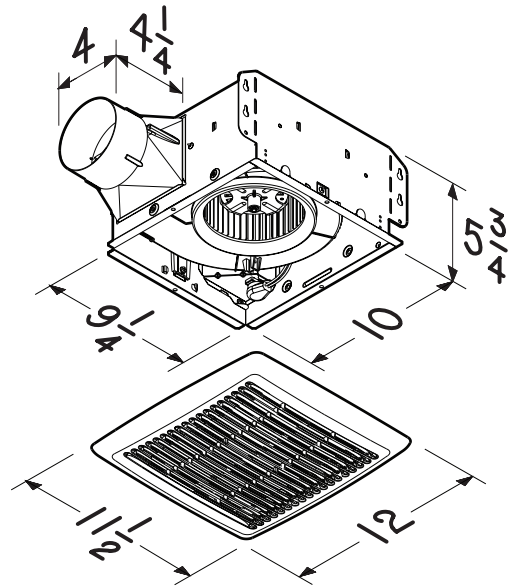

### FAN CAPABILITY

