

LWP FILTER BOX
MODELS LWP 20 THRU LWP 60 (EXHAUST/SUPPLY)

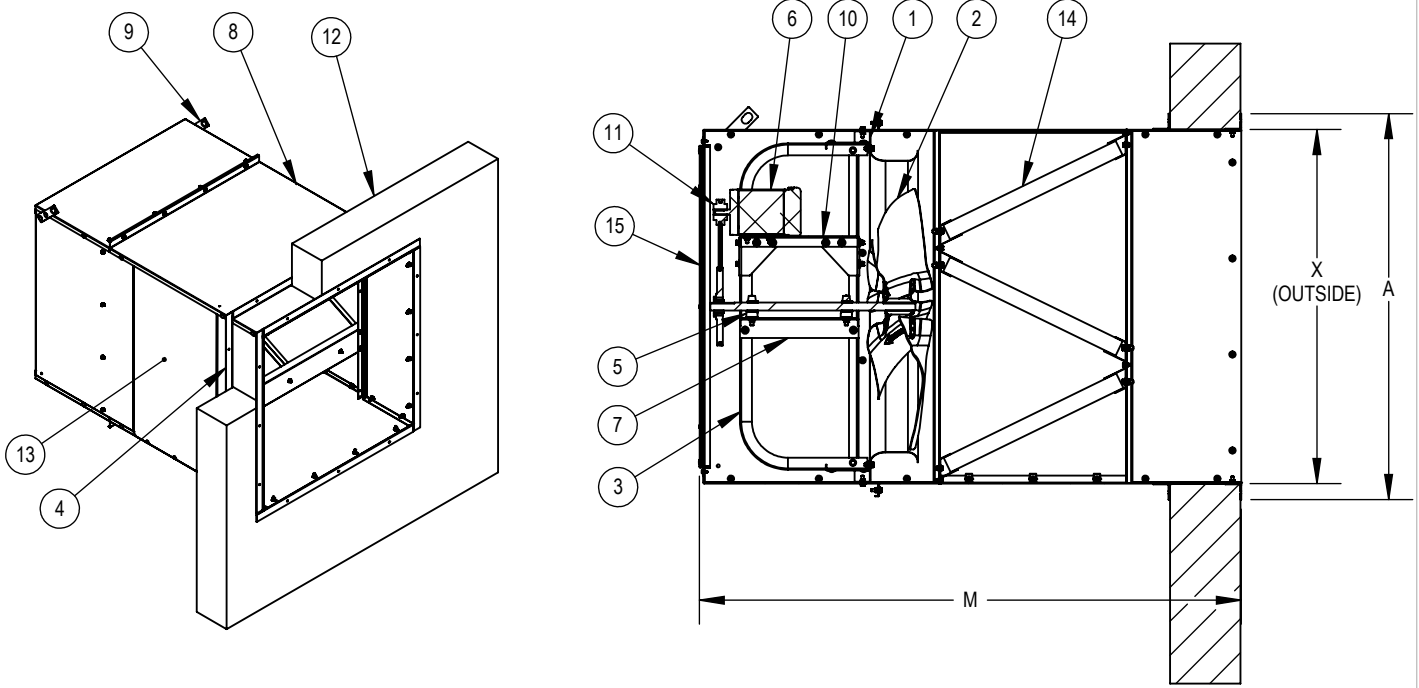

LEGEND

- | | | |
|---|--------------------------|---------------------------------|
| 1 VENTURI PANEL | 5 DRIVE SHAFT & BEARINGS | 10 MOTOR MOUNTING PLATE |
| 2 PROPELLER | 6 MOTOR | 11 PULLEYS |
| 3 STRUCTURE ASSEMBLY | 7 BEARING MOUNTING PLATE | 12 WALL (BY OTHERS) |
| 4 PERIMETER ANGLE FRAME
(ADJUSTABLE TO WALL THICKNESS) | 8 GALVANIZED FILTER BOX | 13 ACCESS PANEL (REMOVABLE) |
| | 9 HANGER SUPPORT BRACKET | 14 FILTERS (SEE TABLE FOR QTY.) |
| | | 15 SCREEN GUARD |

DIMENSIONAL DATA

MODEL	X sq(OUTSIDE)	A	M	FILTER QTY.
20	26 5/16	30 1/4	63 1/2	4
24	32 5/16	36 1/4	63 1/2	4
30	38 5/16	42 1/4	65 1/2	4
36	44 5/16	48 1/4	67 3/4	6
42	50 5/16	54 1/4	72 5/8	6
48	56 5/16	60 1/4	72 5/8	12
54	62 5/8	66 5/16	80 3/16	12
60	68 5/8	72 5/16	80 3/16	12

ALL DIMENSIONS IN INCHES.

REVISION:

FORM:

REPLACES: