

**LWP DAMPER GUARD
 MODELS LWP 20 THRU LWP 60 (EXHAUST)**

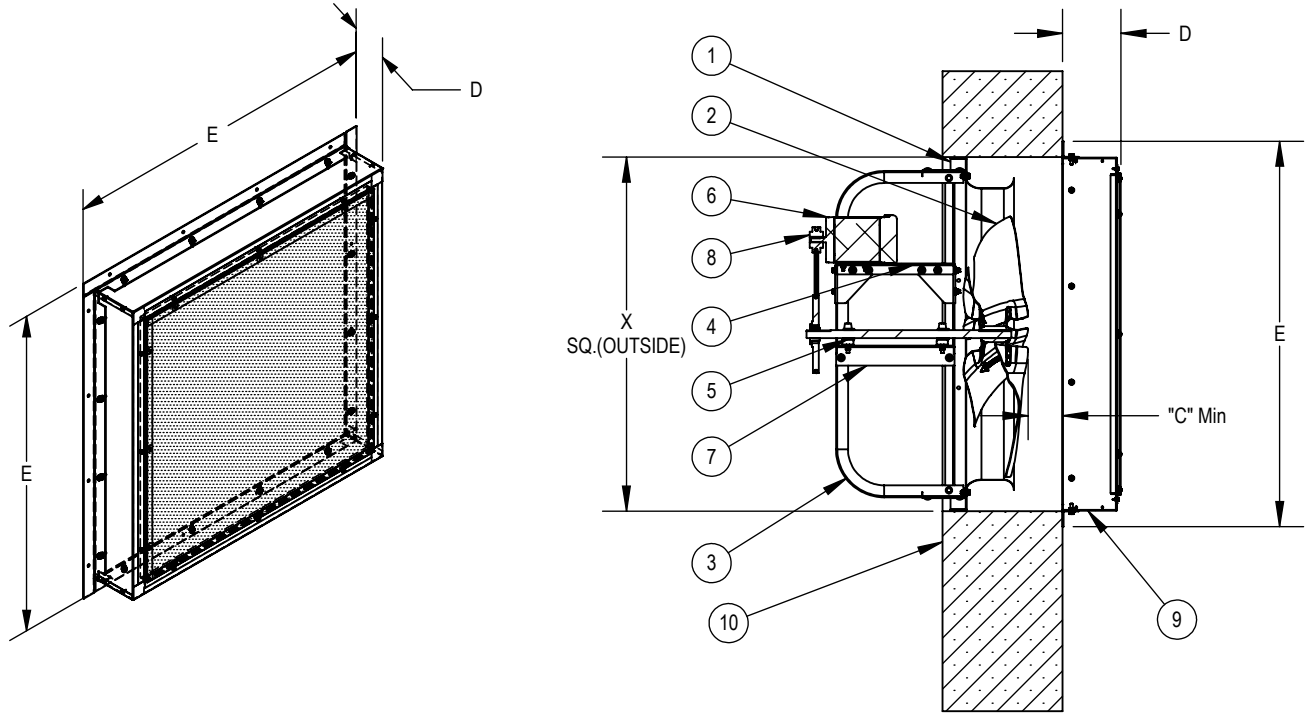

LEGEND

- | | | |
|------------------------|--------------------------|---------------------|
| 1 VENTURI PANEL | 5 DRIVE SHAFT & BEARINGS | 9 DAMPER GUARD |
| 2 PROPELLER | 6 MOTOR | 10 WALL (BY OTHERS) |
| 3 STRUCTURE ASSEMBLY | 7 BEARING MOUNTING PLATE | |
| 4 MOTOR MOUNTING PLATE | 8 PULLEYS | |

DIMENSIONAL DATA

MODEL	X SQ(OUTSIDE)	E	D	"C" (MIN)
20	26 15/16	30 1/4	6 15/16	6
24	32 15/16	36 1/4	6 15/16	6
30	38 15/16	42 1/4	6 15/16	6
36	44 15/16	48 1/4	7 5/16	6
42	50 15/16	54 1/4	8 1/16	6
48	56 15/16	60 1/4	8 1/16	6
54	62 5/8	66 15/16	8 1/16	6
60	68 5/8	72 15/16	8 1/16	6

ALL DIMENSIONS IN INCHES.

REVISION:

FORM:

REPLACES: