

CENTREX INLINER(SX1.5) SX 125 / 155 / 165

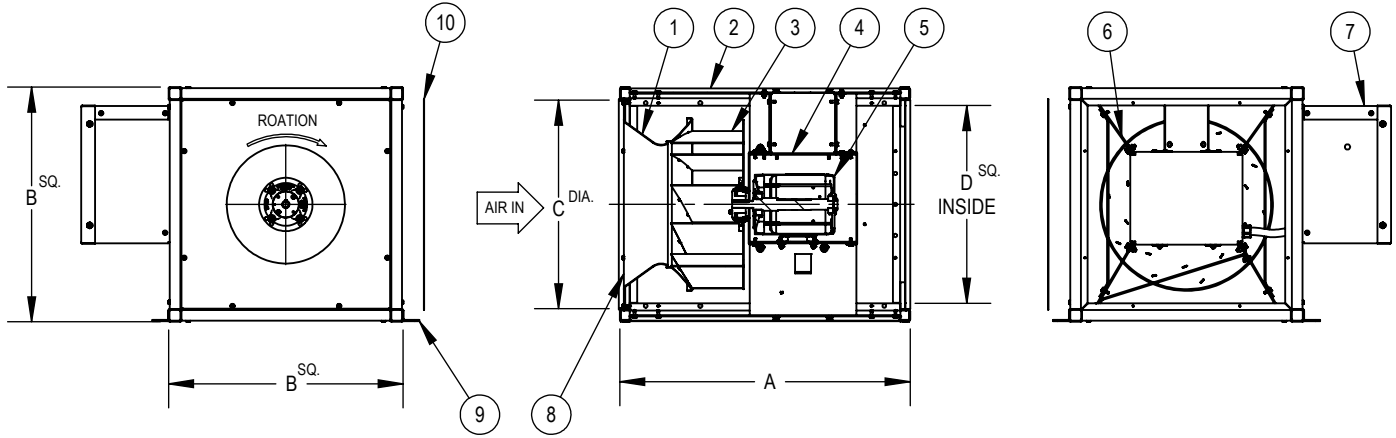

DIMENSIONAL DATA

	A	B	C	D
SX-125	27.22	22.00	19.50	18.54
SX-155	33.00	28.00	25.63	24.54
SX-165	33.00	28.00	25.63	24.54

ALL DIMENSIONS IN INCHES.

LEGEND

- | | | |
|-------------------------|--------------------------|----------------------------|
| 1 SPUN INLET VENTURI | 4 REMOVABLE MOTOR PANELS | 7 CONTROLLER PANEL BOX |
| 2 EXTERIOR FAN CASING | 5 MOTOR | 8 ROUND INLET RING (OPT.) |
| 3 CENTRIFUGAL FAN WHEEL | 6 MOTOR SUPPORT PLATE | 9 VIBRATION HANGER SUPPORT |
| | | 10 REMOVABLE ACCESS PANELS |

FEATURES

- INSTALLED EITHER HORIZONTALLY, VERTICALLY OR AT ANY ANGLE DETERMINED BY THE DUCT WORK
- PMAC MOTOR
- MINIMUM DUCT DIMENSIONS
- AMCA CERTIFIED RATINGS FOR SOUND AND AIR PERFORMANCE
- UL705 (ZACT/ZACT7), FILE #E28413 CERTIFIED

OPTIONS

- | | | |
|--|--|---|
| <ul style="list-style-type: none"> • VIBRATION HANGER <input type="checkbox"/> NONE <input type="checkbox"/> CEILING MOUNTING | <ul style="list-style-type: none"> • FLEX PAD <input type="checkbox"/> NONE <input type="checkbox"/> FLOOR MOUNTING | <ul style="list-style-type: none"> • FAN GUARD |
| <ul style="list-style-type: none"> • VIBRATION ISOLATOR <input type="checkbox"/> NONE <input type="checkbox"/> FLOOR MOUNTING | <ul style="list-style-type: none"> • SUPPORT CHANNELS <input type="checkbox"/> NONE <input type="checkbox"/> FLOOR OR WALL MOUNTING | |

NOTE:

1. PRODUCT AVAILABLE ONLY WITH MOTOR (SYMAX PMAC).

REVISION: _____

FORM: _____

REPLACES: _____