

# Tubeaxial - Direct Drive Model TXD - 097

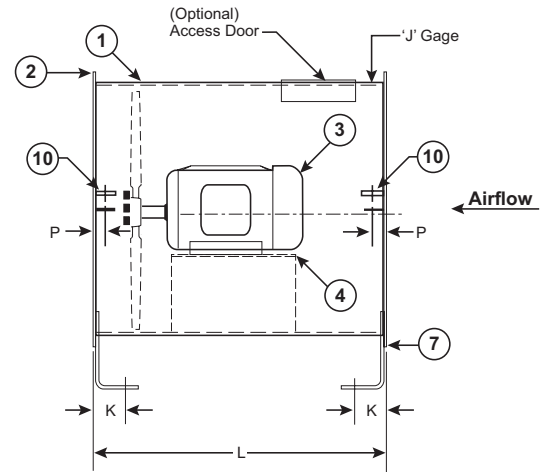
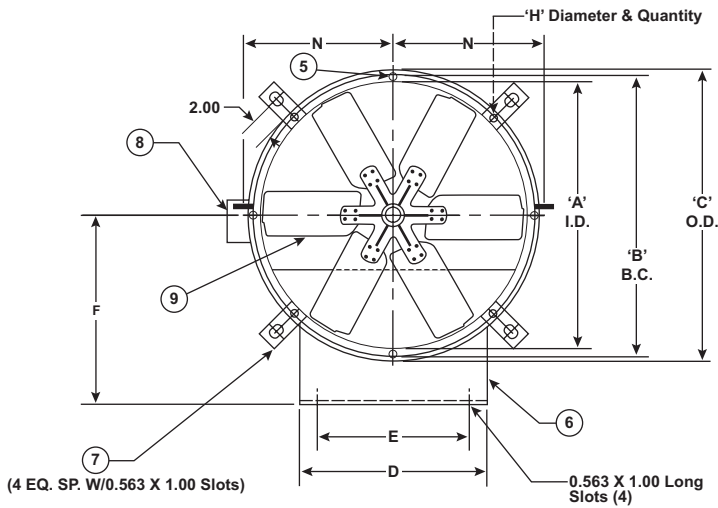

## Legend

- |  |  |
|--|--|
| <ul style="list-style-type: none"> <li>1. Steel Fan Casing</li> <li>2. Duct Flanges</li> <li>3. Ball Bearing Motor</li> <li>4. Motor Support Plate</li> <li>5. Duct Flange Mounting Holes</li> </ul> | <ul style="list-style-type: none"> <li>6. Horizontal Mounting Legs (optional)</li> <li>7. Vertical Mounting Legs (optional)</li> <li>8. Junction Box (optional)</li> <li>9. Fabricated Steel Prop (Type 'S')</li> <li>10. Horizontal Ceiling Clips (optional)</li> </ul> |
|--|--|

## Dimensional Data

Size	A	B	C	D	E	F	H	J	K	L. Mtr. Frame Size								N	P	(1) Unit Weight	
										48-56	143-145	182-184	213-215	254-256	284-286	324-326	364-365				404-405
012	12.19	13.50	14.38	11.00	9.00	11.00	.438-8	14	1.68	18.00	18.00	—	—	—	—	—	—	7.19	3.08	30	
015	15.19	16.50	17.44	14.00	12.00	13.00	.438-8	12	1.71	18.00	18.00	24.00	—	—	—	—	—	8.69	3.10	50	
018	18.19	19.81	21.19	17.00	15.00	14.50	.438-8	12	1.71	18.00	18.00	24.00	24.00	—	—	—	—	10.16	3.10	80	
021	21.22	22.97	24.22	20.00	18.00	16.00	.438-8	12	1.71	18.00	18.00	24.00	24.00	—	—	—	—	12.17	3.10	100	
024	24.25	26.06	27.25	22.00	18.00	18.00	.438-8	12	1.71	24.00	24.00	24.00	24.00	30.00	—	—	—	13.69	3.10	150	
027	27.28	29.13	30.28	26.00	22.00	20.00	.438-8	12	1.71	24.00	24.00	24.00	24.00	30.00	—	—	—	15.22	3.10	170	
030	30.31	32.19	33.31	29.00	25.00	21.50	.438-8	12	1.71	—	24.00	24.00	24.00	30.00	—	—	—	16.74	3.10	200	
032	32.34	34.19	35.34	31.00	27.00	23.00	.438-16	12	1.71	—	24.00	24.00	24.00	30.00	30.00	—	—	17.75	3.10	250	
036	36.38	38.19	39.38	35.00	31.00	25.00	.438-16	10	1.73	—	24.00	24.00	24.00	30.00	36.00	36.00	—	19.75	3.13	350	
042	42.44	44.81	46.44	40.00	36.00	29.00	.563-16	10	1.73	—	—	24.00	30.00	30.00	36.00	36.00	—	23.28	3.13	450	
048	48.50	50.88	52.50	46.00	42.00	33.25	.563-16	10	1.73	—	—	24.00	30.00	30.00	36.00	36.00	36.00	—	26.31	3.13	550
054	54.56	57.00	58.56	52.00	48.00	36.25	.563-16	7	1.78	—	—	—	—	36.00	36.00	42.00	42.00	48.00	29.38	3.18	900
060	60.63	63.00	64.63	56.00	52.00	39.25	.563-16	7	1.78	—	—	—	—	36.00	36.00	42.00	42.00	48.00	32.38	3.18	1050
072	72.75	75.13	76.88	60.00	56.00	45.38	.563-16	0.25	1.78	—	—	—	—	42.00	42.00	48.00	48.00	54.00	39.38	4.00	1400

(1) Approximate fan weights are less motors, drives and accessories.  
See "Estimated Shipping Weights" supplement for estimated motor shipping weights.

<p><b>PENNBARRY™</b> 1401 North Plano Road, Richardson, TX 75081 Ph: 972.234.3202 Fax: 972.497.0468 www.PennBarry.com</p>	<h2 style="margin: 0;">Submittal Sheet</h2> <h3 style="margin: 0;">Model TXD - 097</h3> <h3 style="margin: 0;">Tubeaxial</h3> <h3 style="margin: 0;">Direct Drive</h3>
---	--

This drawing illustrates our understanding of order requirements. When approved, it represents details for fabrication, as such, PennBarry will not be responsible for revisions in the field or other changes after release for fabrication. Published and protected by PennBarry, Richardson, TX. All rights reserved. May not be reproduced partially or in full without permission from the publisher. No rights conveyed to manufacture partially or in full, use or sell either the method of construction represented or any invention in any way related thereto.