



TUB - Tubular Centrifugal Fan

Description

PennBarry fans consist of a fan housing, impeller, shaft, bearings and motor mounting plate (where required). All impellers are statically and dynamically balanced.

Receiving and Inspection

PennBarry fans are carefully inspected before leaving the factory. When the unit is received, inspect the packaging for any signs of tampering. Inspect the unit for any damage that may have occurred during transit and check for loose, missing or damaged parts. Mishandled units can void the warranty provisions. If units are damaged in transit, it is the responsibility of the receiver to make all claims against the carrier. PennBarry is not responsible for damages incurred during shipment.

Avoid severe jarring and/or dropping. Handle units with care to prevent damage to components or finishes. If the unit is scratched due to mishandling, the protective coating may be damaged. Incorrect lifting may damage the fan and void the warranty.

Handling

Fans should be hoisted with slings placed around the fan housing. When a single hoist is used, a "spreader" will keep the sling from slipping on the housing. If it is necessary to use hooks placed in lifting holes of fan, BE CAREFUL NOT TO DISTORT OR BEND THE HOUSING. Large units may have lifting lugs or holes which should be used only to stabilize the unit while using a sling to support the weight.

Chain or wire slings should be well-padded where they contact the fan, especially where special coatings and paints are involved. Rubber, phenolic enamels, etc. require special care as they may easily be damaged by contact in lifting. Even a small chip will destroy the corrosion prevention seal of the coating and allow corrosion to start. Always repair scratched surfaces with touch up of like coating prior to installation.

Storage

Store in a dry, protected area being sure fan shaft, bearings and impeller are protected against dust and corrosion.

If it is necessary to store outdoors or within a building under construction, special care must be taken to prevent moisture, corrosion, dirt or dust accumulation. Coat the shaft with grease or rust preventative compound. Cover and seal bearings to prevent entrance of contaminants. Impeller should be rotated at least once a month to circulate the grease in bearings.

If stored outdoors over seven (7) days, cover completely with a tarp or heavy waterproof paper. Electrical connections and leads must be protected from moisture. Block impeller to prevent natural rotation. Do not allow material of any kind to be piled on top or inside of fan.

Long Term Storage (Over 1 month)

Long-term storage is defined as storage for period exceeding one month from the date the equipment was received. Fans and motors should be stored in a dry, low humidity area indoors.

Equipment which is to be installed, but not operated for several months, should first be blocked to take the weight off of the vibration isolators (if provided), and then given the same protection, periodic inspection and maintenance as a unit in storage.

To prevent puddle corrosion of fan bearings that undergo long-term storage the following preventive maintenance must be performed:

1. Fan bearings must be relubricated every month until the fans are put into service. A clear 1/16" bead of grease must appear on each side of the bearings. Fan wheels are to be rotated manually while the bearings are relubricated. Refer to the specific bearing lubrication instructions located on the fan housing for the type of lubricant to use.
2. Inlet vanes should be operated at least once a month while in storage. A spray lubricant such as:
Dow Corning Molykote 557
Dow Corning Molykote G Spray-Bonded Lubricant or
equivalent should be applied to the bushing joints to assure corrosion protection while in storage.
3. Motor bearings should be lubricated as recommended by the motor manufacturer.

Surface Protection

Most fans are available with special paint finished to protect the fan against a wide variety of adverse conditions. The

standard finish furnished without additional charge is well suited for indoor use. Fans installed in severe outdoor applications (i.e., coastal areas, etc.) may require additional surface protection. The outdoor finish must be compatible with Alkyd base paint. Architecturally pleasing colors are available from many paint manufacturers. This allows the owner to make the outside color choice at the time of the fan installation to match architectural features of the building.

Bearing Protection

Fans equipped with standard duty bearings have been test run at the factory. These bearings are prelubricated and should not require any additional grease for startup. However, if unit is not put in service immediately, it is advisable to add lubricant so as to expel any air voids in the bearing reservoir which may ultimately collect condensation or moisture. The excess lubricant which is expelled at startup through the seals should not be replaced. This purging action will permit cooler operation and remaining grease will be adequate to **properly** lubricate the bearing. During the inactive period, the bearing should be protected from the elements by a securely attached plastic film and rotated several turns once a month. On belt driven units, it is advisable to protect the bearings from contamination by covering the belt guard opening with a suitable material. Belts should be removed from the motor sheave and stored in the guard. This will allow both the guard and the motor to be completely covered with a waterproof material.

Safety Precautions

DO. . . .

1. Make sure unit is stopped and electrical power is locked out before putting hands into inlet or outlet

opening or near belt drive. We suggest a LOCK-OUT and a warning sign on the start switch cautioning not to start the unit.

- Follow maintenance instructions.
- Make sure all drive guards are installed at all times fan is in operation. If the inlet or outlet is exposed, a suitable guard should also be installed.
- Take special care not to open any fan or system access panels while the system is under pressure (negative or positive).
- Never allow untrained or unauthorized persons to work on equipment.
- Take special care when working near electricity. Also insure the power is off and can not be turned on while servicing the fan.
- Keep area near equipment clean.

CAUTION

- DO NOT** put hands near or allow loose or hanging clothing to be near belts or sheaves while the unit is running.
- DO NOT** put hands into inlet or outlet while unit is running. It is sometimes difficult to tell whether or not it is running . . . be sure it is not running and cannot be operated before doing any inspection or maintenance.
- DO NOT** operate fan with guards removed.
- DO NOT** take chances.

SAFETY FIRST!!!

Installation

Mounting holes have been provided for mounting to either stationary or resilient bases. Fans must be located and fastened firmly in a level position. The motor and drive are then mounted in their proper relative positions, if not already mounted on the fan.

Wheel Clearance

Before starting up a fan, the wheel should be inspected to assure that the assembly

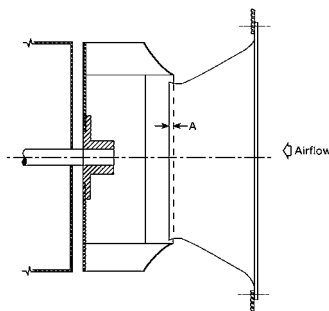

Table 1: Inlet funnel/wheel cone overlap

FAN SIZE	"A" DIMENSION (in.)
90	3/16
105	3/16
122	5/16
135	11/32
150	3/8
165	7/16
182	9/16
200	5/8
222	5/8
245	3/4
270	7/8
300	1 1/16
330	1 1/8
365	1 1/8
402	1 1/4
445	1 3/8
490	1 1/2
542	1 5/8
600	1 7/8
660	2 1/16
730	2 1/4
807	2 1/2
890	2 3/4

Table 2: Max speeds (rpm) for steel and aluminum wheels

FAN SIZE	CLASS		
	I	II	III
90	4150	NA	NA
105	3600	NA	NA
122	3642	4000	NA
135	3173	4000	NA
150	2827	3643	4000
165	2561	3327	3869
182	2303	2990	3762
200	2102	2729	3433
222	1889	2453	3085
245	1715	2227	2802
270	1506	1949	2436
300	1355	1754	2192
330	1232	1594	1993
365	1090	1416	1768
402	989	1284	1603
445	894	1161	1450
490	812	1055	1316
542	733	953	1189
600	633	861	1075
660	603	783	977
730	545	708	884
807	493	640	799
890	447	580	725

Notes:

- Maximum rpm is based on operating temperature of 100°F; from 101°F through 200°F, multiply RPM by 0.93.
- Sizes 122 through 165 are backward inclined wheels and sizes 182 through 890 are airfoil wheels.

Belt Guard

Protective cover surrounding the moving parts, provided for personal safety. Available with tachometer opening, where specified. Totally enclosed or "OSHA" type guard also available.

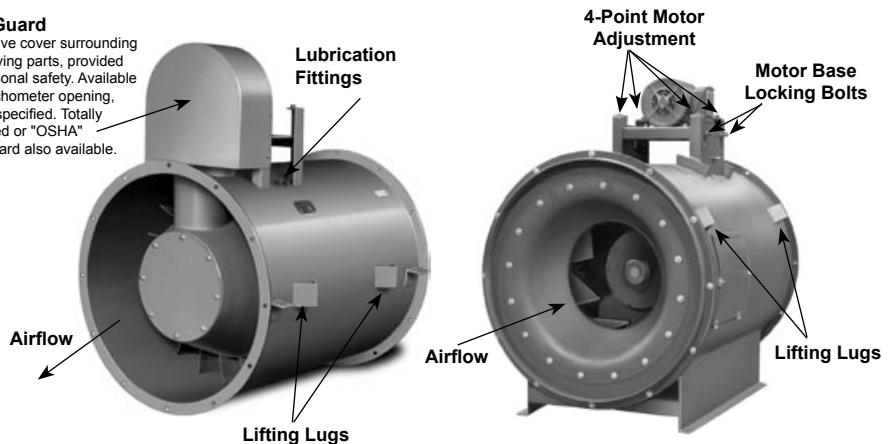

has not shifted while in transit. Incorrect wheel clearance could cause damage to the wheel and housing, and lower the efficiency of the fan. The clearance between the wheel and housing should be equal around the entire circumference of the wheel.

Temporary Heat

The warranty on this fan will be voided if the fan is used for temporary heat during construction of the building.

Motor and Drive Alignment

It is important that motor pulleys and fan pulleys be properly aligned to allow belts to run true and straight. Misalignment can

result in blower noise and excessive belt wear.

Belt Tension

To assure performance and belt life, proper tensioning of the belts is required. Adjustable motor bases are provided on Arrangement 9 fans for belt tensioning. Belt tension should be provided such that belt slippage does not exceed one (1) second duration at fan start up. Check belt tension at least two (2) times during the first day of operation.

Fan Rotation

Fan rotation per AMCA is determined from the discharge end of the fan. PennBarry

provides a rotation sticker on the fan housing for verification. Bump start the fan to confirm rotation is correct before running fan at full speed. Running the fan in reverse may overload and possibly damage the motor.

Motors

▲ WARNING Always disconnect or shut off electrical power before attempting to service fan and/or motor.

All AC induction motors will perform satisfactorily with a 10% variation in voltage, a 5% variation in frequency or a combination voltage-frequency variation of 10%. For motors rated 208-220 volts, the above limits apply only to 220 volt rating. To select control for 208-220 volt motors, use same amps for either 208 or 220 volts.

Motors are received with bearings lubricated and require no lubrication for some time depending on operating conditions. (See MAINTENANCE SECTION on Motor Bearings)

TO REVERSE DIRECTION OF ROTATION

Single Phase Motors

Shaded Pole Rotation cannot be reversed unless motor is constructed so that the shading coil on one half of the stator pole can be shifted to the other half of the stator pole.

Split Phase Interchange connections to supply of either main or auxiliary winding.

Capacitor All types of capacitor motors are reversed in rotation by interchanging connections to supply of either main or auxiliary winding.

Repulsion Remove plate on motor end bracket and turn bracket (holding Brushes) in direction **opposite** to direction of existing rotation.

NOTE: It is suggested that rotation change be made for single phase motors by the manufacturer's approved repair shop.

Three Phase Motors

To reverse rotation, interchange any two line leads.

Normal operation of motors results in temperature rise. Permitted temperature rise depends on type of motor installation. The total motor operating temperature includes ambient temperature plus motor temperature rise. The motor temperature rise includes nameplate temperature rise, service factor allowance and hot spot allowance.

IMPORTANT NOTE:

MOTORS ARE WARRANTED BY THE MOTOR MANUFACTURER. PENNBARRY WILL ASSIST IN LOCATING A LOCAL VENDOR APPROVED REPAIR SHOP, IF REQUIRED.

Motor Lubrication and Maintenance

Regrease or lubricate motor bearings according to manufacturer's recommendations. DO NOT OVER LUBRICATE. Motor manufacturer's lubrication recommendations are printed on tags attached to motor. Should these tags be missing the following will apply:

FRACTIONAL HORSEPOWER BALL BEARING MOTORS:

Under normal conditions, ball bearing motors will operate for five years without relubrication. Under continuous operation at higher temperature (but not to exceed 140°F ambient) relubricate after one year.

INTEGRAL HORSEPOWER BALL BEARING MOTORS

Motors having pipe plugs or grease fittings should be relubricated while warm and at a stand still. Replace one pipe plug on each end shield with grease fitting. Remove other plug for grease relief. Use low pressure grease gun and lubricate until grease appears at grease relief. Allow motor to run for 10 minutes to expel excess grease. Replace pipe plugs.

Recommended relubrication intervals - **general guide only.**

H.P. Range	Standard Duty 8 Hr./Day	Severe Duty 24 Hr./Day Dirty, Dusty	Extreme Duty Very Dirty High Ambients
1 1/2 - 7 1/2	5 Years	3 Years	9 Months
10 - 40	3 Years	1 Year	4 Months
50 - 150+	1 Year	9 Months	4 Months

These ball bearing greases or their equivalents are satisfactory for ambient temperatures from 20°F to 200°F.

- Chevron SRIU #2 (Standard Oil of California)
- Chevron BRB #2 (Standard Oil of California)
- Premium RB (Texaco, Inc.)
- Alvania No. 2 (Shell Oil Company)

Make certain motor is not overloaded. Check amps. with nameplate.

KEEP MOTORS DRY. Where motors are idle for a long time, single phase heaters or small space heaters might be necessary to prevent water condensation in windings.

Start-Up

Before Start-Up:

Fastenings - It is recommended that all foundation bolts, impeller hub set screws and bearing set screws be checked for tightness before start-up.

Access Doors - They should be tight and sealed.

NOTE: The maximum torque values for weld studs are as follows:

STUD SIZE	TORQUE (FL. LBS.)
1/4"	5
15/16"	10
3/8"	17
1/2"	39
5/8"	83

The fan bearings, whether pillow block or flange mounted, are prelubricated and should not require additional grease for start-up.

"Bump" the motor to check for proper impeller rotation. The motor should be started in accordance with manufacturer's recommendations.

Bearings - Check bearing alignment and make certain they are properly locked to shaft.

Impeller - Turn over rotating assembly by hand to see that it runs free and does not bind or strike fan housing. If impeller strikes housing, it may have to be moved on the shaft or bearing pillow blocks and reshimmed. Check location of impeller in relation to fan inlets. Be sure fan housing is not distorted. See ALIGNMENT section.

Driver - Check electrical wiring to the motor. See MOTOR section.

Guards - Make certain all safety guards are installed properly.

Belt Drive - Must be in alignment; with belts at proper tension. See BELT DRIVE section.

Duct Connections - The connections from fan to ductwork must not be distorted. Ducts should never be supported by the fan. Expansion joints between duct connections should be used where expansion is likely to occur or where the fan is mounted on vibration isolators. All joints should be sealed to prevent air leaks and all debris removed from ductwork and fan.

Dampers and Variable Inlet Vanes (VIVs) - They should operate freely with blades closed tightly. All dampers and VIVs should be partially closed during starting periods to reduce power requirements. This is particularly important for a fan designed for high temperature operation being "run in" at room temperature or at appreciably

less than design temperature. When air is up to temperature, the damper or VIV may be opened. Complete closing of dampers could cause the fan to run rough.

Fan may now be brought up to speed. Watch for anything unusual such as vibration, overheating of bearings and motors, etc. Multi-speed motors should be started at lowest speed and run at high speed only after satisfactory low speed operation. Check fan speed on belt drive units and adjust motor sheave to give the desired RPM. Balance system by adjusting damper or VIVs.

At first indication of trouble or vibration, shut down and check for cause of difficulty.

Maintenance

Always disconnect or shut off fan before attempting any maintenance.

A definite time schedule for inspecting all rotating parts should be established. The frequency of inspection depends on the severity of operation and the location of the equipment.

Fan bearing alignment should be checked at regular intervals. Misalignment can cause overheating, wear to bearing dust seals, bearing failure and/or unbalance.

Fan bearings should be lubricated at regular intervals. Periodic inspection will be necessary. If grease is found to be breaking down, replenish grease by pumping new grease into bearing until all the old grease has been evacuated. See section on BEARING LUBRICATION.

Bearings on high speed fans tend to run hot: 75°F to 100°F above ambient. Do not replace a bearing because it feels too hot to touch. Place a contact thermometer against the bearing pillow block and check the temperature. Before you investigate high temperature, realize that ball or roller bearing pillow blocks can have a total temperature of 225°F (107°C). High temperature bearings are rated at 425°F (218°C).

Foundation bolts and all set screws should be inspected for tightness.

Fans should be inspected for wear and dirt periodically. Any dirt accumulated in housing should be removed. The impeller may have to be cleaned. A wash down with steam or water jet is usually sufficient, covering bearings so water will not enter the pillow blocks. Impellers having worn blades should be replaced. Impellers require careful rebalancing before being returned to service. Replacement impellers should have the balance checked upon start-up and corrected as required to operate properly in its specific application.

Repairing of exterior and interior parts of fans and ducts will extend the service life of the installation. Select a paint which will withstand the operating temperatures. For normal temperatures a good machinery paint may be used. Corrosive fumes require all internal parts to be wire brushed, scraped clean and repainted with an acid resisting paint. Competent advice should be sought when corrosive fumes are present.

Blow out open type motor windings with low pressure air to remove dust or dirt. Air pressure above 50 psi should not be used, as high pressure may damage insulation and blow dirt under loosened tape. Dust can cause excessive insulation temperatures. Do **not exceed** OSHA air pressure requirements.

Excessive vibration will shorten the life of any mechanical device. Correct any imbalance situation before returning fan to service.

LUBRICATION OF HINGE BEARINGS ON POWER ROOF VENTILATORS

Stack cap damper hinge bearings are oil impregnated and may never need lubrication. A drop or two of 10W30 motor oil every 6 to 12 months will not hurt the bearings. Check damper operation to detect binding or checking. Adjust hinge pin bearing bracket to resume free damper operation.

SHAFT COOLING WHEEL OPTION (HIGH TEMPERATURE UNITS)

For some high temperature applications, a shaft cooling wheel is factory installed. Fan maintenance may require the cooling wheel to be removed. Be certain to reassemble the cooling wheel with the fins towards the bearings. Reversing the assembly will heat rather than cool the shaft. **Mark** one side of the split in the cooling wheel and **match mark** the shaft so that the cooling wheel can be repositioned on the shaft where it was originally installed. Changing the angular position of the cooling wheel on the shaft will affect the dynamic balance of the fan.

LUBRICATION LINES - PLASTIC OR COPPER

Lubrication lines installed at the factory are not filled with grease at the factory. Caution must be used when first greasing the bearings to purge air from the lines without blowing bearing seals or over-greasing a bearing.

ADJUSTABLE MOTOR BASE

Belt drives can be aligned and adjusted by loosening clamping bolts and sliding motor axially and retightening. Belt tension can be fine tuned adjusted by loosening or tightening the adjustment bolts. Loosen

clamping bolts first, then adjust adjusting bolts and retighten clamping bolts. Belt tension is adjusted with the adjusting bolts and maintained with the clamping bolts.

FAN MECHANICAL BALANCING

Fan impellers are balanced statically and dynamically by the factory, but may require further trim balancing. The final installed vibration level of the fan is also dependent upon its installation and foundation. Fans shipped completely assembled have been trim balanced at the factory.

Before any attempt is made at balancing, check for any other causes of vibration or unbalance as listed in the TROUBLESHOOTING CHECKLIST.

A fan handling clean air should not need rebalancing after original balance. Dust build-up on fan blades or wear can cause fan unbalance. Periodic inspection of the fan should be made to determine the amount of dirt build-up or wear.

Portable instruments are available that will indicate vibration in mils (1 mil = 0.001 inches). Each fan has a Quality Assurance label affixed to the fan. All pertinent information on factory balance is recorded on the label for the owner's information and use.

IMPORTANT NOTE:

THE FAN MUST BE CHECKED AND CORRECTED FOR ANY OUT OF BALANCE CONDITION ANY TIME A COMPONENT OF THE ROTATING ASSEMBLY IS REPLACED OR ALTERED.

LUBRICATION OF ANTI-FRICTION BEARINGS

Bearings on assembled fans receive their initial lubrication from the bearing manufacturer. Bearings shipped separate from the fan or as a replacement may not be lubricated before shipment. When there is the slightest doubt, the safe practice is to assume that the bearing has not been lubricated. Always turn fan off before lubricating.

For grease lubricated ball or roller bearing pillow block, a good grade of grease, free from chemically or mechanically active material should be used. These greases are a mixture of lubricating oil and a soap base to keep the oil in suspension. They have an upper temperature limit where oil and soap base oxidize and thermally decompose into a gummy sludge.

Mixing of different lubricants is not recommended. If it is necessary to change to a different grade, make or type of lubricant, flush bearing thoroughly before changing. Regreasing will vary from 3 months to a year depending on the hours of operation, temperature and surrounding

conditions. Special greases may be required for a dirty or wet atmosphere (consult your lubricant supplier).

When grease is added, use caution to prevent any dirt from entering the bearing. The pipe plug or grease relief fitting should be open when greasing to allow excess grease to flow out. The pillow block should be about 1/3 full, as excess grease may cause overheating. Use a low pressure gun.

These ball bearing greases or their equivalents are satisfactory for ambient temperatures from 20°F to 200°F.

- Chevron SRIU #2 (Standard Oil of California)
- Chevron BRB #2 (Standard Oil of California)
- Premium RB (Texaco, Inc.)
- Alvania No. 2 (Shell Oil Company)

FREQUENCY OF LUBRICATION

The bearings are lubricated at predetermined intervals and the condition of the grease established as it is purged out of the seals or by examination of the grease in the housing. An average installation where the environmental conditions are clean and room temperatures prevail may only require bearing lubrication every 3 to 6 months, while operation in a dirty atmosphere at high temperatures will require much more frequent intervals. Base your particular interval on condition of grease after a specific service period.

The following chart is intended as a guideline for your consideration. (Figure 1)

BELT DRIVES

Fans shipped completely assembled have had the belt drive aligned at the factory. Alignment must be checked before operation.

- Be sure sheaves are locked in position.

- Key should be seated firmly in keyway.
- The motor and fan shafts must be properly aligned, with the center line of the belts at a right angle to the shafts.
- Start the fan. Check for proper rotation of impeller. Run fan at full speed. A slight belt bow should appear on the slack side. Adjust belt tension by adjusting motor on its adjustable base.
- If belts squeal excessively at start-up, they are too loose and should be tightened.
- When belts have had time to seat in the sheave grooves, readjust belt tension. Check belt tension after 8, 24 and 100 hours of operation.

BELT DRIVE ASSEMBLY CAN BE MOUNTED AS FOLLOWS:

- Clean motor and drive shafts. Be sure they are free from corrosive material. Clean bore of sheaves and coat with heavy oil for ease of shaft entry. Remove oil, grease, rust or burrs from sheaves. Place fan sheave on fan shaft and motor sheave on its shaft. **DO NOT POUND ON** sheave as it may result in damage. Tighten sheaves in place.
- Move motor on base so belts can be placed in grooves of both sheaves without forcing. Do not roll belts or use tool to force belts over grooves.
- Align fan and motor shafts so they are parallel. The belts should be at right angles to the shafts. A straight edge or taut cord placed across the faces of the sheaves will aid in alignment with single groove sheaves. If multiple groove sheaves are installed, use the center line of the drive as your alignment point.

- Tighten belts by sliding motor in its base. Correct tension gives the best efficiency. Excessive tension causes undue bearing pressure.
- Be sure all safety guards are in place.
- Start the fan and run at full speed. Adjust belt tension until only a slight bow appears on the slack side of the belts. If slippage occurs, a squeal will be heard at start-up. Eliminate the squeal by tightening the belts.
- Belts require time to become fully seated in the sheave grooves. Check belt tension after 8, 24 and 100 hours of operation. Allowing belts to operate with improper tension will shorten belt life substantially.
- If the shafts become scratched or marked, carefully remove the sharp edges and high spots such as burrs with fine emery cloth or a honing stone. Avoid getting emery dust in the bearings.
- Do not apply any belt dressing unless it is recommended by the drive manufacturer. Belts are designed for frictional contact between the grooves and sides of the belts. Dressing will reduce this friction.
- Minimum belt center distances are available from factory upon request.
- Belt tension on an adjustable pitch drive is obtained by moving the motor, **not by changing the pitch diameter** of the adjustable sheaves.

Disassembly of Fan

Before removing any equipment, the fan's power source should be locked "off" for personal safety. The position of mating parts such as bearing, drive, etc., should be marked in their relative position for simplifying assembly.

1. Remove all safety guards.
2. Disconnect ducting or supports to remove fans.
3. Remove drive cover plate to provide access to inner housing for Arr. 9 fans.
4. Remove drive from fan.
5. Clean off the shaft, removing dirt and burrs and lubricate with oil for bearing and wheel removal.
6. Loosen setscrews on pillowblock bearing and remove the bearings (Arr. 9 fan only). Bearing bars should be checked with straightedge to determine if the bar has a crown, and bearings shimmed accordingly when assembled.

Figure 1: Frequency of Lubrication

SHAFT SIZE	OPERATING SPEED (RPM)									
	500	1000	1500	200	2500	3000	3500	4000	450	5000
	LUBRICATION FREQUENCY (Months)									
.50" - 1.00"	6	6	6	6	6	6	4	4	2	2
1.06" - 1.44"	6	6	6	6	6	6	4	4	2	1
1.50" - 1.75"	6	6	6	4	4	2	2	2	1	1
1.88" - 2.19"	6	6	4	4	2	2	1	1	1	
2.25" - 2.44"	6	4	4	2	2	1	1	1		
2.50" - 3.00"	6	4	4	2	1	1	1			
3.06" - 3.50"	6	4	2	1	1	1				
3.56" - 4.00"	6	4	2	1	1					

Assembly of Fan

To reassemble fan, reverse the process as listed above. Care should be taken once the fan is reassembled to assure components are firmly fastened and aligned. Shimming of bearings may be required to attain proper bearing and shaft alignment. Also, the straightedge should be laid across the full-length of the bearing mounting plate to determine if a crown exists. Shim each bearing accordingly. Wheel clearances and split housed bearing assembly tolerances must be adhered to. PennBarry requires that for any rotating assembly replacements, the fan should be rebalanced.

Vibration Tolerances

All fans are dynamically balanced at the factory before shipment. The dynamic balance is made utilizing a PMC, IRD or Schenck analyzer at the operating speed if known, or the maximum RPM of the unit. Measurements are taken off both bearings in mil readings of displacement. The readings will meet or exceed the guidelines as established in AMCA Std. 204-96, "Balance Quality and Vibration Levels for Fans." Final measurements are recorded on PennBarry's inspection copies. When motors and drives are not provided by PennBarry it will be necessary for the customer to provide a trim balance in the field.

Ordering Replacement Parts

When ordering replacement parts it is necessary to provide PennBarry with the serial number of the unit and/or the original shop order number on which the fan was ordered. Typical replacement parts are as follows:

1. Wheel
2. Housing
3. Shaft
4. Bearings
5. Motor
6. Drives

When ordering replacement parts, specify any required accessories, such as special material, flanges and coatings. This will assure that the replacement parts are correct.

Vibration Severity Chart

Vibration Frequency* - CPM

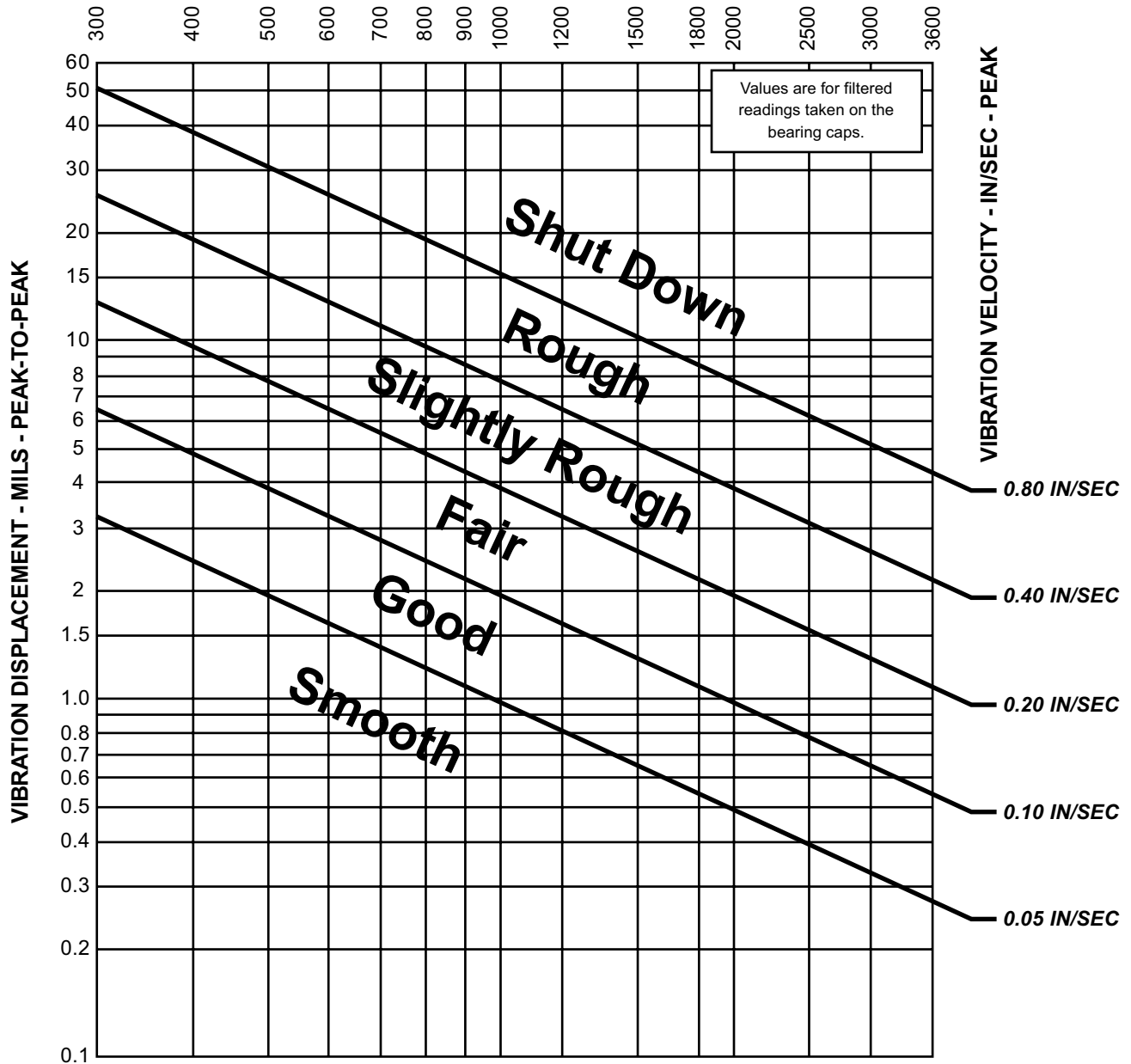

*Frequency corresponds to RPM when dynamic imbalance is the cause of vibration.

Guidelines for Interpreting the Classifications on the Severity Chart

Smooth: Alignment, balance and the integrity of the support structure must be near perfect and the vibration from sources other than the fan equipment must be low.

Good: Requires reasonable care on installation, proper foundation, good balance on the rotating components and good alignment of the running gear.

Fair: Fan equipment can operate in this region, but imperfections are indicated.

Slightly Rough: Requires service. Continued use in this condition will reduce equipment life. Monitor equipment for deterioration.

Rough: Requires service. Dangerous operating conditions for fan equipment. Shut equipment down.

Shut Down: Do not operate fan equipment. Potential for catastrophic failure.

Troubleshooting Checklist

In the event trouble is experienced in the field, listed below are the most common fan difficulties.

Symptom	Possible Cause(s)	Corrective Action
Capacity or Pressure Below Rating	<ol style="list-style-type: none"> 1. Total resistance of system higher than anticipated 2. Speed too low 3. Dampers or variable inlet vanes improperly adjusted. 4. Poor fan inlet or outlet conditions 5. Air leaks in system 6. Damaged impeller or incorrect direction of rotation 	<ol style="list-style-type: none"> 1. System problems 2. Adjust drive 3. Adjust 4. Elbows at or too close to fan 5. Seal joints / correct damper settings 6. Correct
Vibration and Noise	<ol style="list-style-type: none"> 1. Misalignment of impeller, bearings, couplings 2. Unstable foundation 3. Foreign material in fan causing unbalance 4. Worn bearings 5. Damaged impeller or motor 6. Broken or loose bolts or set screws 7. Bent shaft 8. Worn coupling 9. Impeller or driver unbalanced 10. 60/120 Hz cycle magnetic hum due to electrical input 11. Fan delivering more than rated capacity 12. Loose dampers or VIVs 13. Speed too high or fan rotating in wrong direction 14. Vibration transmitted to fan from some other source 	<ol style="list-style-type: none"> 1. Loosen, align, tighten 2. Inferior design, start over 3. Remove 4. Replace bearings and shaft 5. Check and repair 6. Replace 7. Replace 8. Replace 9. Balance 10. Check for high or unbalanced voltage 11. Reduce speed 12. Adjust and tighten 13. Correct 14. Isolate
Overheated Bearings	<ol style="list-style-type: none"> 1. Too much grease in ball bearings 2. Poor alignment 3. Damaged impeller or drive 4. Bent shaft 5. Abnormal end thrust 6. Dirt in bearings 7. Excessive belt tension 	<ol style="list-style-type: none"> 1. Allow run time to purge (24 hours) 2. Correct 3. Inspect, correct or replace 4. Replace 5. Loosen set screws and adjust 6. Replace bearing; use filtered grease 7. Adjust
Overloaded Motor (Pulls too many AMPs)	<ol style="list-style-type: none"> 1. Speed too high 2. Discharge over capacity due to existing system resistance being lower than original rating 3. Specific gravity or density of gas above design value 4. Wrong direction of rotation 5. Poor alignment 6. Impeller wedging or binding on inlet bell 7. Bearings improperly lubricated 8. Motor improperly wired 	<ol style="list-style-type: none"> 1. Reduce speed or change HP 2. Adjust system resistance 3. Recalculate and correct 4. Correct 5. Correct 6. Loosen and adjust 7. See page 4 8. Verify and correct
Motor Problems	<ol style="list-style-type: none"> 1. Check for low or high voltage from power source 2. High temperature; drawing too much current or dirt in windings 3. Vibration and noise 4. Armature rubs against stator 5. Too much or not enough lubrication in bearings 6. Commutator brushes on d-c motor worn or not seated under proper tension 7. Vibration and noise; loose hold down bolts 8. Low insulation resistance due to moisture 	<ol style="list-style-type: none"> 1. Correct voltage 2. Repair motor 3. Correct armature imbalance 4. Replace worn bearings 5. Correct lubrication 6. Repair motor 7. Tighten hold down bolts 8. Check resistance with a megohm meter ("Megger") or similar instrument employing a 500 volt d-c potential. Resistance should read at least 1 megohm

Note: Care should be taken to follow all local electrical, safety and building codes. Provisions of the National Electric Code (NEC), as well as the Occupational Safety and Health Act (OSHA) should be followed.

All motors are checked prior to shipment. If motor defects should develop, prompt service can be obtained from the nearest authorized service station of the motor manufacturer while under warranty. Exchange, repair or replacement will be provided on a no charge basis, if the motor is defective within the warranty period. The PennBarry representative in your area will provide a name and address of an authorized service station, if requested.

WARNING: Motor guarantee is void unless overload protection is provided in motor wiring circuit.

Limited Warranty

What Products Are Covered

PennBarry Commercial and Industrial Fans (each, a “PennBarry Product”)

One Year Limited Warranty For PennBarry Products

PennBarry warrants to the original commercial purchaser that the PennBarry Products will be free from defects in material and workmanship for a period of one (1) year from the date of shipment.

Exclusive Remedy

PennBarry will, at its option, repair or replace (without removal or installation) the affected components of any defective PennBarry Product; repair or replace (without removal or installation) the entire defective PennBarry Product; or refund the invoiced price of the PennBarry Product. In all cases, a reasonable time period must be allowed for warranty repairs to be completed.

What You Must Do

In order to make a claim under these warranties:

1. You must be the original commercial purchaser of the PennBarry Product.
2. You must promptly notify us within the warranty period of any defect and provide us with any substantiation that we may reasonably request.
3. The PennBarry Product must have been installed and maintained in accordance with good industry practice and any specific PennBarry recommendations.

Exclusions

These warranties do not cover defects caused by:

1. Improper design or operation of the system into which the PennBarry Product is incorporated.
2. Improper installation.
3. Accident, abuse or misuse.
4. Unreasonable use (including any use for non-commercial purposes, failure to provide reasonable and necessary maintenance as specified by PennBarry, misapplication and operation in excess of stated performance characteristics).
5. Components not manufactured by PennBarry.

Limitations

1. In all cases, PennBarry reserves the right to fully satisfy its obligations under the Limited Warranties by refunding the invoiced price of the defective PennBarry Product (or, if the PennBarry Product has been discontinued, of the most nearly comparable current product).
2. PennBarry reserves the right to furnish a substitute or replacement component or product in the event a PennBarry Product or any component of the product is discontinued or otherwise unavailable.
3. PennBarry’s only obligation with respect to components not manufactured by PennBarry shall be to pass through the warranty made by the manufacturer of the defective component.

General

The foregoing warranties are exclusive and in lieu of all other warranties except that of title, whether written, oral or implied, in fact or in law (including any warranty of merchantability or fitness for a particular purpose).

PennBarry hereby disclaims any liability for special, punitive, indirect, incidental or consequential damages, including without limitation lost profits or revenues, loss of use of equipment, cost of capital, cost of substitute products, facilities or services, downtime, shutdown or slowdown costs.

The remedies of the original commercial purchaser set forth herein are exclusive and the liability of PennBarry with respect to the PennBarry Products, whether in contract, tort, warranty, strict liability or other legal theory shall not exceed the invoiced price charged by PennBarry to its customer for the affected PennBarry Product at the time the claim is made.

Inquiries regarding these warranties should be sent to: PennBarry, 1401 North Plano Road, Richardson, TX 75081.