

ESP Horizontal Plenum AF Arrangement 3, SWSI, Class I & II

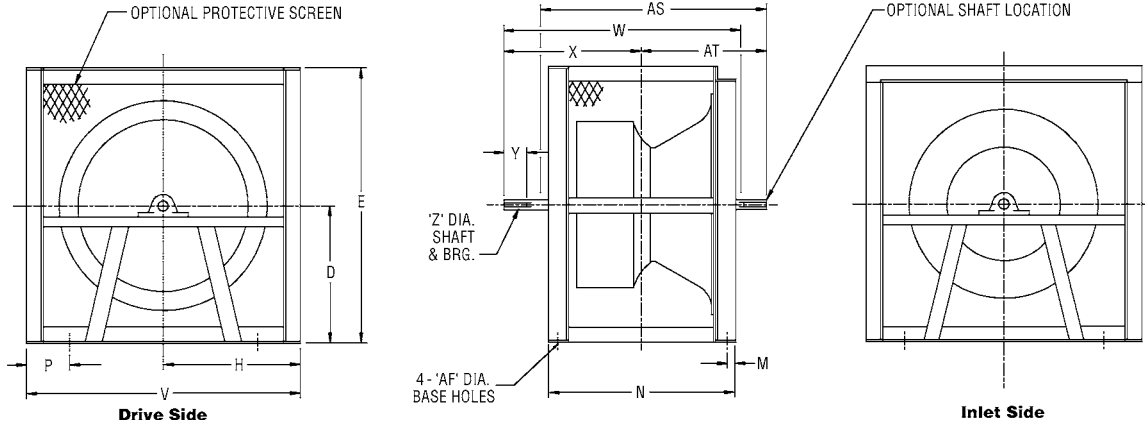

Notes:

1. CW & CCW rotation available. Rotation and motor position are determined from side opposite inlet.
2. Dimensions should not be used for construction. Certified drawings are available upon request.

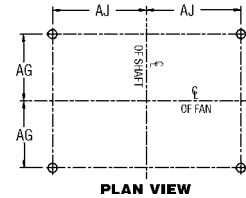

Dimensional Data

Size	D	E	H	V	N	Class I		Class II		Y	'Z' - Class I		'Z' - Class II		Class I		Class II		P	M	AF	AG	AJ	Angle
						W	X	W	X		Shaft	Keyway	Shaft	Keyway	AS	AT	AS	AT						
600	44.50	82.00	37.50	75.00	55.38	66.63	37.00	66.88	37.25	6.00	2.438	0.63 x 0.31	2.938	0.75 x 0.38	67.13	37.88	66.88	37.88	5.63	1.88	0.81	25.81	31.88	4.00 x 3.00
660	49.00	90.00	41.00	82.00	62.50	74.88	41.63	76.63	42.75	7.00	2.688	0.63 x 0.31	3.438	0.88 x 0.44	76.38	43.38	76.63	43.38	7.88	2.38	0.81	28.88	33.13	5.00 x 3.50
730	46.00	92.00	46.00	92.00	68.00	80.88	45.00	82.50	46.00	7.50	2.938	0.75 x 0.38	3.438	0.88 x 0.44	82.25	46.63	82.88	46.63	8.88	2.38	0.81	31.63	37.13	5.00 x 3.50
807	48.50	97.00	48.50	97.00	74.00	87.38	48.50	88.88	49.50	8.00	2.938	0.75 x 0.38	3.438	0.88 x 0.44	88.75	50.00	89.25	50.00	7.63	2.38	0.81	34.63	40.88	5.00 x 3.50
890	54.00	108.00	54.00	108.00	80.25	95.25	52.63	95.63	52.75	8.00	3.438	0.88 x 0.44	3.938	1.00 x 0.50	95.63	53.25	95.75	53.25	7.63	2.38	0.81	37.75	46.38	5.00 x 3.50

Dimensions in inches.

<p>PENNBARRY™</p> <p>1401 North Plano Road, Richardson, TX 75081 Ph: 972.234.3202 Fax: 972.497.0468 www.PennBarry.com</p>	<h2 style="margin: 0;">Submittal Sheet</h2> <h3 style="margin: 0;">ESP Horizontal Plenum AF Arrangement 3, SWSI, Class I & II</h3>
------------------------------------------------------------------------------------------------------------------------------------------	--------------------------------------------------------------------------------------------------------------------------------------------

This drawing illustrates our understanding of order requirements. When approved, it represents details for fabrication, as such, PennBarry will not be responsible for revisions in the field or other changes after release for fabrication. Published and protected by PennBarry, Richardson, TX. All rights reserved. May not be reproduced partially or in full without permission from the publisher. No rights conveyed to manufacture partially or in full, use or sell either the method of construction represented or any invention in any way related thereto.