

**PLEASE READ AND SAVE THESE INSTRUCTIONS.**

Read carefully before attempting to assemble, install, operate or maintain the product described. Protect yourself and others by observing all safety information. Failure to comply with instructions could result in personal injury and/or property damage! Retain instructions for future reference.

PENN BARRY

# Zephyr Power Pack Replacement Parts For Discontinued Zephyr Models Z3 Thru Z13H

## Receiving and Handling

PennBarry fans are carefully inspected before leaving the factory. When the unit is received, inspect the carton for any signs of tampering. Inspect the unit for any damage that may have occurred during transit and check for loose, missing or damaged parts. Mishandled units can void the warranty provisions. PennBarry is not responsible for damages incurred during shipment.

Avoid severe jarring and/or dropping. Handle units with care to prevent damage to components or special finishes.

## Storage

Long-term storage requires special attention. Units should be stored on a level, solid surface, preferably indoors. If outside storage is necessary, protect the units against moisture and dirt by encasing the cartons in plastic or some similar weatherproof material.

## Unpacking

Place carton in an upright position and remove staples or use a sharp (knife edge) tool to CAREFULLY cut or scribe the sealing tape on both sides at the top of the carton. Open carton flaps. Remove any cardboard and wooden filler pieces, as well as loose components or accessories shipped with the unit.

Carefully remove the unit from the carton. Inspect the unit for any damage that may have occurred during transit and check for loose, missing or damaged parts.

## Installation

### IMPORTANT SAFETY INFORMATION

It is important that you verify the model number, especially if your installation was after September 1994, when these models were generally discontinued. If the unit model number is any of the above numbers followed by an S, H or S/H or another number (such as Z102S/H), it is our current offering and this power pack is not the correct replacement part.

1. Prior to performing any work, disconnect and lock-out power source to the fan.
2. Follow common sense, basic safety precautions regarding the use of step ladders used to gain access to the fan, suitable "drop lights", proper use of power tools, if desired (only hand tools are required for these procedures), etc.
3. Hard hat are recommended! Especially if working beneath a fan, while hardware is not fully tightened, ensure parts do not fall out. This is true while removing and reinstalling the power pack.

### SINGLE BLOWER ASSEMBLY

**NOTE:** All single blower replacement power packs are shipped from the factory in an RA configuration.

1. If ceiling mount, remove grill. If inline installation, remove access door. In either case, reach hand in and pull plug from junction box.
2. The power pack is held by four (4) screws to the sheet metal housing. Loosen and remove these screws to remove the ENTIRE power pack as one assembly from the sheet metal housing.
3. Determine if the installation configuration is RA, TDA, or TD (Refer to figures 3, 4 and 5 on page 2).
4. If the unit is either RA or TDA,
  - The replacement power pack is installed into the housing using the same four (4) screws into their original locations.
  - Install plug into the junction box.
  - Install the ceiling grill or access panel.

5. If the unit is TD, PRIOR to installing replacement power pack, the blower scroll must be rotated. (See Figures 1 and 2).
  - On the replacement power pack, remove the four (4) screws holding blower scroll to mounting plate.
  - Rotate scroll to discharge vertically away from mounting plate.

**Figure 1: 'RA' & 'TDA'  
As Supplied By Factory**

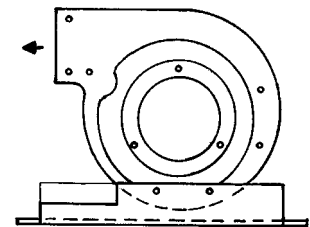

- Replace the four (4) screws to attach scroll to mounting plate.
  - Install re-oriented power pack into the housing using the same four (4) screws into their original locations.
  - Install plug into the junction box.
  - Install ceiling grill.
6. Restore electrical power to unit.

**Figure 2: 'TD' If Required By Installer**

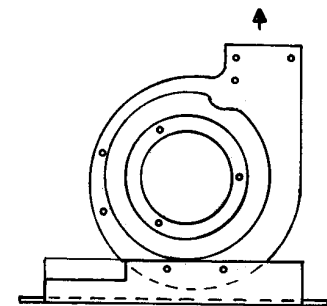

**DOUBLE BLOWER ASSEMBLY**

1. If ceiling mount, remove grill. If inline installation, remove access door. In either case, reach hand in and pull plug from junction box.
2. Unit power pack mounting plate is installed onto a raised mounting platform inside the sheet metal housing via three (3) screws. To release the power pack from the mounting platform, remove the two (2) rear screws and LOOSEN only the one (1) front screw.
3. To remove the power pack, while sliding it away from the loosened screw, you must also ROTATE the power pack, tilting the blower forward towards the sheet metal housing, to clear the mounting platform and remove it from the housing.
4. To install the replacement power pack, this procedure must be reversed. While sliding the mounting plate onto the mounting platform front screw, rotate the assembly back into the housing to align the blower discharges to the housing outlet connections.
5. Tighten the front screw, and replace the rear two (2) screws.
6. Install plug into the junction box.
7. Install the ceiling grill or access panel.
8. Restore electrical power to unit.

**Figure 3: 'RA' (Right Angle)**

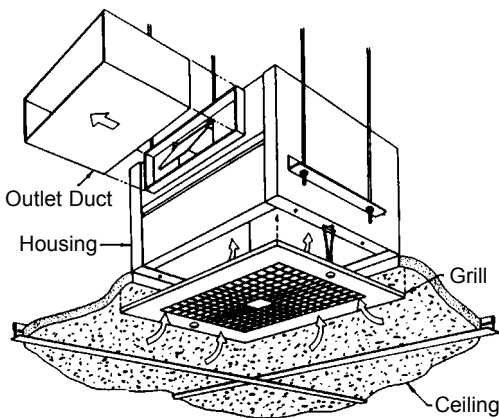

**Figure 4: 'TD' (Top Discharge)**

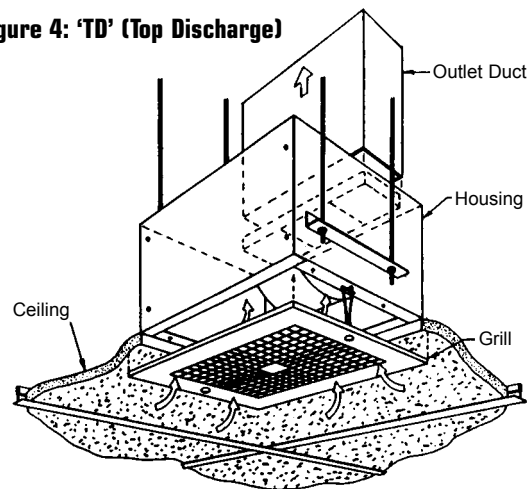

**Figure 5: 'TDA' (Inline)**

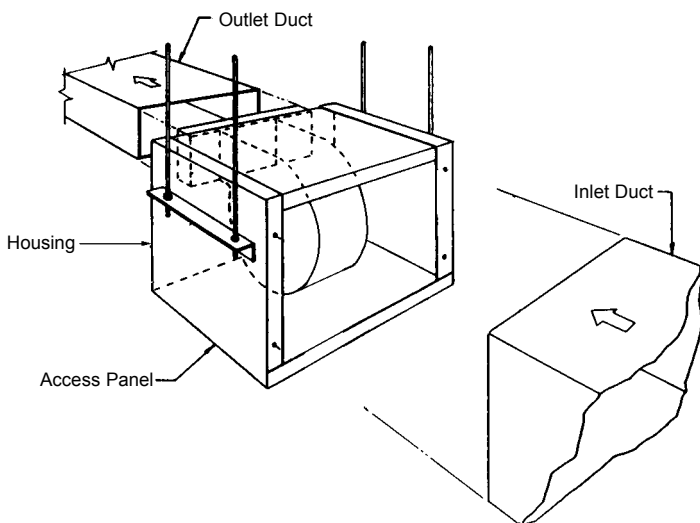

---

# Limited Warranty

---

## What Products Are Covered

PennBarry Fans and Ventilators (each, a "PennBarry Product")

## One Year Limited Warranty For PennBarry Products

PennBarry warrants to the original commercial purchaser that the PennBarry Products will be free from defects in material and workmanship for a period of one (1) year from the date of shipment.

## Exclusive Remedy

PennBarry will, at its option, repair or replace (without removal or installation) the affected components of any defective PennBarry Product; repair or replace (without removal or installation) the entire defective PennBarry Product; or refund the invoice price of the PennBarry Product. In all cases, a reasonable time period must be allowed for warranty repairs to be completed.

## What You Must Do

In order to make a claim under these warranties:

1. You must be the original commercial purchaser of the PennBarry Product.
2. You must promptly notify us, within the warranty period, of any defect and provide us with any substantiation that we may reasonably request.
3. The PennBarry Product must have been installed and maintained in accordance with good industry practice and any specific PennBarry recommendations.

## Exclusions

These warranties do not cover defects caused by:

1. Improper design or operation of the system into which the PennBarry Product is incorporated.
2. Improper installation.
3. Accident, abuse or misuse.
4. Unreasonable use (including any use for non-commercial purposes, failure to provide reasonable and necessary maintenance as specified by PennBarry, misapplication and operation in excess of stated performance characteristics).
5. Components not manufactured by PennBarry.

## Limitations

1. In all cases, PennBarry reserves the right to fully satisfy its obligations under the Limited Warranties by refunding the invoice price of the defective PennBarry Product (or, if the PennBarry Product has been discontinued, of the most nearly comparable current product).
2. PennBarry reserves the right to furnish a substitute or replacement component or product in the event a PennBarry Product or any component of the product is discontinued or otherwise unavailable.
3. PennBarry's only obligation with respect to components not manufactured by PennBarry shall be to pass through the warranty made by the manufacturer of the defective component.

## General

**The foregoing warranties are exclusive and in lieu of all other warranties except that of title, whether written, oral or implied, in fact or in law (including any warranty of merchantability or fitness for a particular purpose).**

**PennBarry hereby disclaims any liability for special, punitive, indirect, incidental or consequential damages, including without limitation lost profits or revenues, loss of use of equipment, cost of capital, cost of substitute products, facilities or services, downtime, shutdown or slowdown costs.**

The remedies of the original commercial purchaser set forth herein are exclusive and the liability of PennBarry with respect to the PennBarry Products, whether in contract, tort, warranty, strict liability or other legal theory shall not exceed the invoice price charged by PennBarry to its customer for the affected PennBarry Product at the time the claim is made.

Inquiries regarding these warranties should be sent to: PennBarry, 1401 North Plano Road, Richardson, TX 75081.