

# CENTREX

Centrifugal Inline Fan

PRODUCT GUIDE

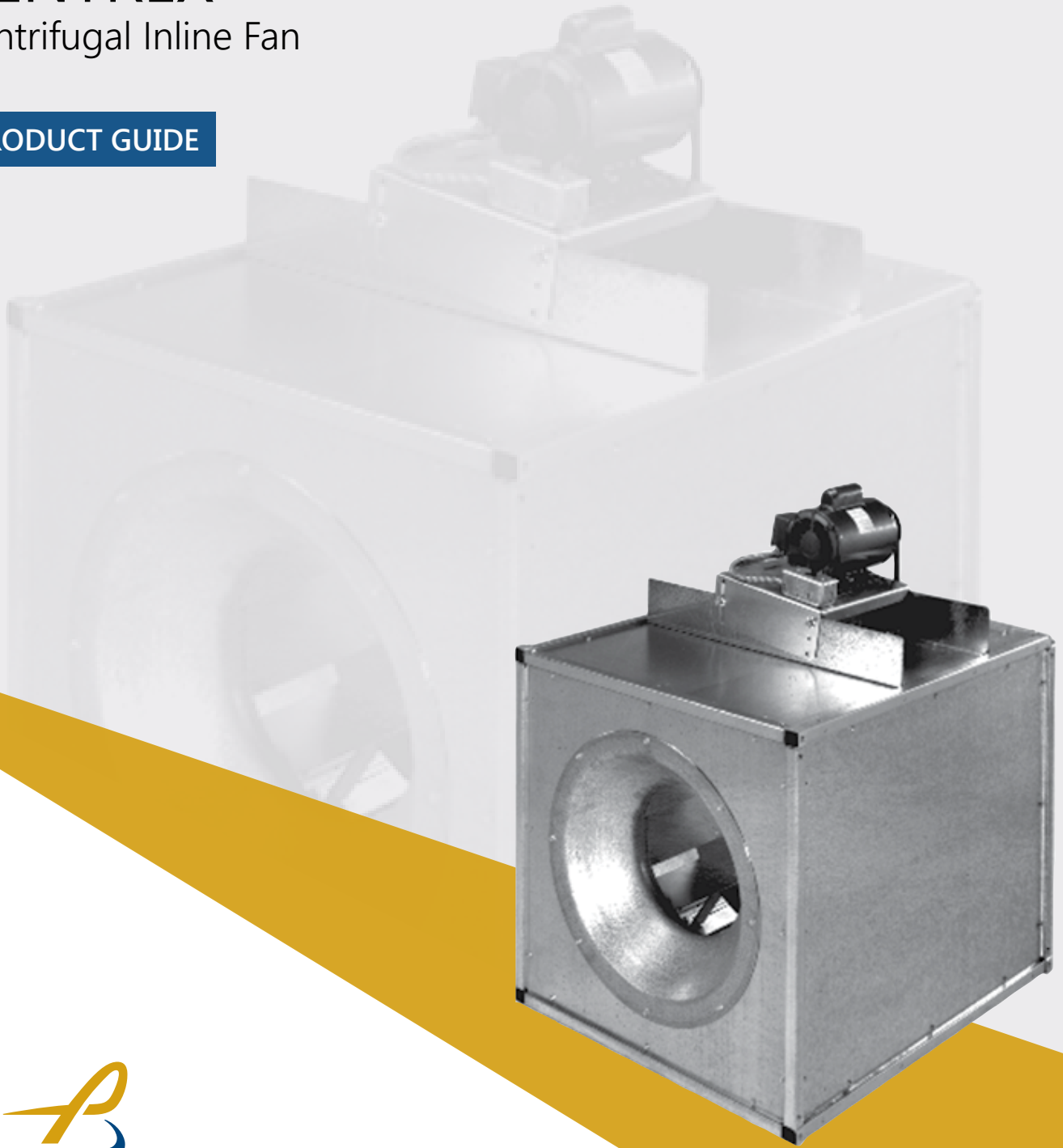

PENNBARRY™

# TABLE OF CONTENTS

INTRODUCTION	3
CERTIFICATIONS & LISTINGS	4
FEATURES & BENEFITS	5-6
OPTIONS & ACCESSORIES	7-8
FILTER OPTIONS	9-10
MOTOR AVAILABILITY	11
MOTOR SELECTION	12
DIRECT DRIVE   DIMENSIONS	13
BELT DRIVE   DIMENSIONS	14
FAN SELECTIONS	15-16

# INTRODUCTION

## Centrex Inliner

Centrex Inliner fans are widely used in square ducts as clean air boosters in both supply and exhaust systems where the installation of conventional blowers is impractical. Their compact design gives designers an excellent alternative to conventional blowers.

As an integral part of a ventilation system layout, Centrex Inliner fans can be installed either horizontally, vertically or at any angle determined by the duct work. Full-size removable panels enable easy access to the fan interior. Direct-drive motors are isolated from the airstream. Belt drive motors are mounted on the outside housing and can be positioned at any angle to avoid existing building obstructions. Optional motor covers are available as belt guards.

Centrex Inliner fans feature durable galvanized steel construction (aluminum is optional for selected belt drive models), which works in conjunction with a patented wheel design and deeply spun inlets to provide smoother flow through the ventilator. The centrifugal wheels are aluminum, non-overloading, backwardly inclined, robotically welded, and dynamically balanced.



*Centrex Belt Drive*

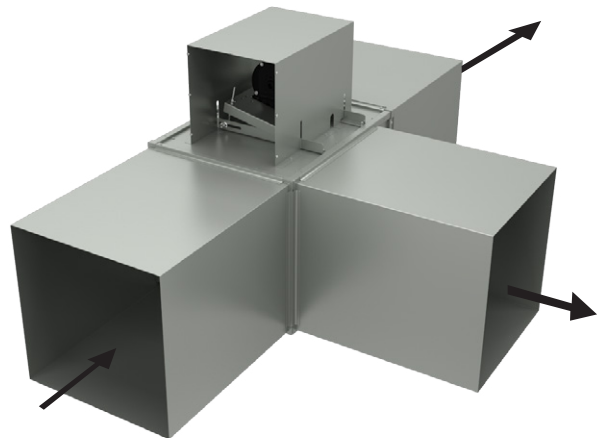

*Side Duct Illustration*



*Centrex Direct Drive*

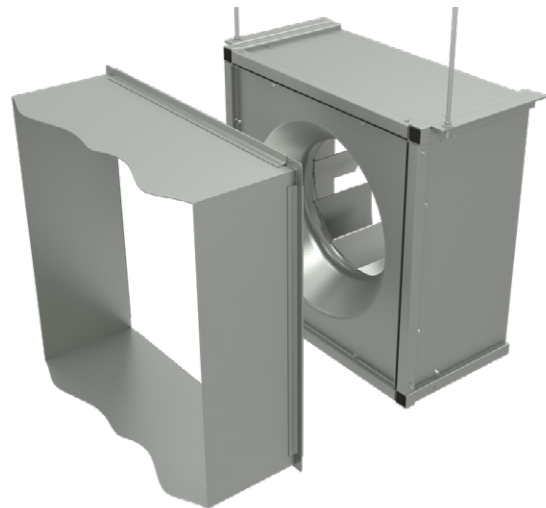

*Mounting Frame Illustration*

### Direct Drive Units

- Static pressure up to 2.5" wg.
- Flow capacity up to 4,620 CFM

### Standard Duty Belt Drive Units

- Static pressure up to 2.5" wg.
- Flow capacity up to 27,502 CFM.

### High Pressure Belt Drive Units

- Static pressure up to 3.5" wg.
- Flow capacity up to 9,249 CFM

# CERTIFICATIONS & LISTINGS



## Centrex AMCA Certifications

PennBarry certifies that the Centrex Inliner models shown herein (except model SX420) are licensed to bear the AMCA seal. The ratings shown are based on tests and procedures performed in accordance with AMCA publications 211 and 311, and comply with the requirements of the AMCA Certified Ratings Program.



## cULus Certification

Centrex Inliner fans carry the UL label, UL705 (ZACT/ZACT7), file #E28413.



WARNING

To fulfill our obligations towards Article 33, in accordance to European REACH Regulation No 1907/2006 EC, we hereby inform you that this article contains the following Substances of Very High Concern mentioned on the Candidate list:

- Lead



WARNING

The SX square inline fan is suitable only for indoors applications. This fan is NOT suitable for outdoors installations. Installing this product in different ways that recommended by the manufacturer voids the warranty

# FEATURES & BENEFITS

## Silent Wheel (Direct Drive and SX100/120BC)

- Blade's highly curved leading edge provides unsurpassed low sound numbers with excellent air performance.
- Backplate and inlet are stamped for consistency; plus, dynamic balancing ensures smooth vibration-free operation.
- Riveted or riveted and welded construction ensures superior dependability over other wheel designs.

## Standard Duty, All Welded Wheel Standard Duty and High Pressure Belt Drive

- Blades are curved for improved air performance while increasing their strength and rigidity.
- Backplate and inlet are stamped for consistency. They include a perimeter rim which enhances strength and improves balancing.
- Wheel assembly is robotically welded to provide extremely durable and consistent performance.
- Wheel is dynamically balanced.

Balancing weights are mechanically attached to both the backplate and wheel inlet. This allows a precise placement of the weights anywhere within a full 360° range on two separate planes, without the possibility of detachment.

## Support Angles

Shipped loose with every unit, these heavy-gauge angles attach to long corner posts. They can also be used to install vibration isolator devices or to bolt the unit to a solid foundation.

## Reverse Venturi

Reverse venturi reduces turbulence and improves distribution of the air as it enters the wheel inlet and is "captured" by the blades.

## Self-Aligning Bearings

Heavy-duty bearings are sized for minimum L50 life in excess of 200,000 hours of operation. One hundred percent factory tested, they are designed for air handling applications

## Drive Belts

Pulleys are pre-set to the specified RPM. Cast iron variable pitch pulleys are adjustable, allowing for field balancing based on actual field conditions. All pulleys are sized for at least 150% of the driven horsepower.

## Aluminum Wheels

Centrex Inliner fans offer patented wheel designs. Carefully matched highly-tooled venturis enhance the performance of these backward inclined and non-overloading centrifugal wheels. Made of advanced aluminum alloys, the various wheel components provide superior strength and durability, as well as spark resistant construction.

## Internal Wiring

All direct drive units comes standard with NEMA 1 internal wiring to an appropriate external junction box. An appropriately paired service switch is available. The initial electrical connection does not require the removal of any access panels. If an upgrade is desired, NEMA 3R wiring is available. Optional internal wiring is also available for belt drive units. Explosion proof units cannot have internal wiring.

## Unique Mounting Frame

Unique "fully flush" mounting frame allows installers to quickly fabricate "flanged" duct ends which can be easily secured with common sheet metal hardware. The duct is connected to a heavy-gauge corner post, ensuring a substantial wall for the fastener threads and a rigid base to hold the shape of the duct work.

## Three Removable Panels

Both side panels are removable for inspection, periodic maintenance, or optional discharge ducting. And, if required for cramped close-to-the-wall installations, once either side panel is removed, the bottom panel can then be removed.

## Speed Controller (Direct Drive only)

These speed controllers allow for adjustment in motor rpm, improving productivity and providing a cost effective means for system balancing

# FEATURES & BENEFITS

## Benefits of Duct Arrangement

Because of the rigid corner post construction of the Inliner, three of the four panels can be removed; only the top motor mounting side is fixed. The removal of these panels is usually for inspection and normal maintenance.

However there is another, and often overlooked, benefit to having this type construction. Any of these three panels, or all of them, can be removed and replaced by a duct connection. This option allows ducting directly out of the sides or bottom of the unit.

- Eliminates the static pressure duct loss through duct fittings.
- Eliminates the cost of one or more field duct fittings.
- Runs with no performance penalty.

In some cases, just the space savings of transitioning directly from the unit can translate into large savings by eliminating a lengthy “out of the way” run of duct.

## Minimum Duct Dimensions

A side discharge duct may either be the full panel size, or smaller if desired. However, if not using a full panel, the duct opening must be installed at the inlet (wheel end) of the unit to avoid excessive “system effect” turbulence. In either case, the corner posts provide an effective surface for duct joints. If this side ducting method is used, the typical straight through outlet may or may not be blocked, depending upon the application.

Model	in.
SX085, SX095, SX100BC	7
SX125BC	11
SX115, SX120BC, SX155BC	12
SX125BCH	13
SX205BCH	14
SX165BC, SX205BC	16
SX225BCH	17
SX275BC	19
SX225BC	20
SX335BC	24
SX420BC	30

# OPTIONS & ACCESSORIES

## Fan Guards (1)

Both inlet and outlet guards are available whenever the unit is a termination point. Guards are highly recommended whenever the fan is mounted within seven feet of occupied space and/or otherwise unprotected by duct work. Each application must be reviewed for compliance with OSHA standards.

## Inlet Flanges (2)

Structural angles formed as circles can be provided to connect unit to round duct systems.

## Support Channels (3)

A pair of formed channels can be used to mount the units horizontally to a solid base.

## Vibration Isolators (4)

A variety of isolation devices for floor mounting are available, including flex pads and rubber in shear or spring isolators. These can be used in conjunction with support angles (standard) or support channels (optional).

## Vibration Hangers (5)

To support installation from overhead structural members, these rubber in shear or spring type isolators attach to threaded rods provided by the installer. Vibration hangers are attached to the unit by support angles (standard) or support channels (optional).

## Motor Cover (6)

In order prevent damage to the drive from outside factors, a motor cover can be selected for protection.

## Safety Service Switch (8)

Safety service switches are available to allow positive electrical shut-off and safety. Switches are factory mounted when factory wiring is requested. Wiring is only run from the motor to the junction box. (Factory wiring of explosion proof applications is not available.) A wide range of NEMA rated enclosures with service switches are available for indoor and explosion proof installations. Service switches are to be field wired by a licensed electrician.

## Backdraft Dampers

Backdraft dampers are available for either gravity or motorized operation (motor kit optional). Dampers feature square galvanized steel frames and multi-leaf, roll formed aluminum blades with nylon bearings.

## Finishes

Coatings such as Polyester Powder Coat, Epoxy Powder Coat, Phenolic Epoxy Powder Coat, and others are available. See the coatings brochure for details.

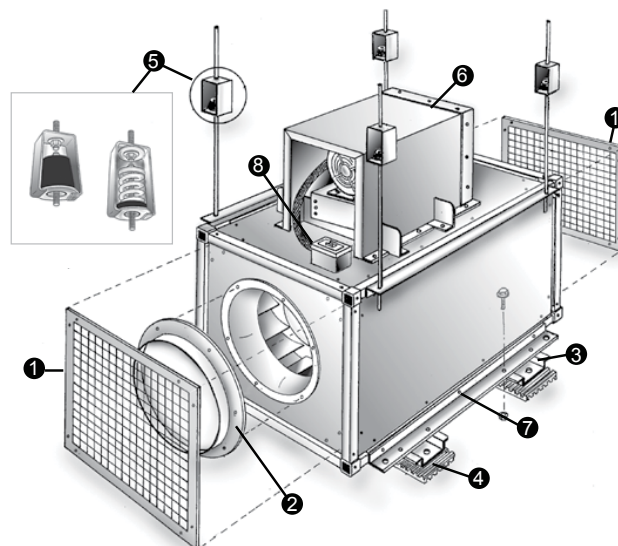

*Installed Accessories Illustration*

# OPTIONS & ACCESSORIES

## Spare belt option

An extra set of one or two spare belts is an available selection.

## Stainless Steel Hardware

If another material is desired for the unit's hardware, stainless steel hardware is available for selection.

## Stainless Steel Shaft

If another material is desired for the motor shaft, stainless steel shafts are available for selection.

## Variable Frequency Drives

Variable frequency drives (VFDs) are designed to meet performance requirements while increasing efficiency. By varying the fan motor input frequency and voltage, the VFD controls the motor speed and torque, helping to improve productivity and lower energy consumption. The VSC and VSA are ideal for both new and retrofit fan applications. Shipped loose and separately.

## AMCA B Construction

Belt drive models, up through SX205BC, are available with aluminum panels and corner posts, providing optimal spark resistance.

## Firestat Switch

Firestat switch automatically disconnects the unit when the temperature of the air being exhausted exceeds a preset rating.

## Time-Delay Switch (Direct Drive Models Only)

The Airminder Model AM12 switch is a UL listed and CSA certified time-delay relay that operates both the fan and room light to ventilate an area even after the occupants depart. In the "On" position, the Airminder turns the light and fan on immediately. In the "Off" position, the light goes off immediately, and the fan is in operation for a period of time as preset from 1 to 60 minutes.



## Speed Controllers

The Lek-trol™ controller allows adjustment in speed to a maximum of 50% reduction, which results in a very cost effective means for system balancing. The device can be located under the motor cover to prevent unauthorized tampering or on the wall for ease of operation by the building occupants. (Available on direct drive units with ODP motors and some select TE motors).



## Lek-Trol™ Controller Options

The table below shows the availability of Lek-Trol™ controllers for direct drive models. There is a controller available for all size models. Not all totally enclosed motors are currently available with variable speed control.

Model	60 Hz.					50 Hz.		
	Open Drip Proof	Totally Enclosed				Totally Enclosed		
		115 V	115 V	200 V	208 V	230 V	110 V	220 V
SX085RC	-	LT30	LT35	LT35	LT35	LT35	LT35	LT35
SX095V/S/RC	LT30	LT30	LT35	LT35	LT35	LT35	LT35	LT35
SX095QC	LT45	LT30	LT35	LT35	LT35	LT35	LT35	LT35
SX115V/S/RC	LT50	-	-	-	-	-	-	-
SX115Q1C	LT40	-	-	-	-	-	-	-
SX115Q2C	LT40	-	-	-	-	-	-	-

*Lek-Trol™ controllers indicated for multi-speed models are applicable only for the high speed. Do not use on low or medium speed for multi-speed models.*



# FILTER OPTIONS

## Filter Box

The filter box is designed for compatibility with the Square Centrex Inliner Fan. The filter box can be directly coupled to the Square Centrex inlet or installed remotely to the Square Centrex in the system duct work.

## Washable Filters

The unit is designed to handle 1" or 2" filters by utilizing tabs in the filter tracks. The filter media is washable aluminum available with a 1" or 2" inch thickness. Disposable filters are also available.

## Removable Side Panels

The side panels are removable for easy filter access from either side of the unit.



# FILTER OPTIONS

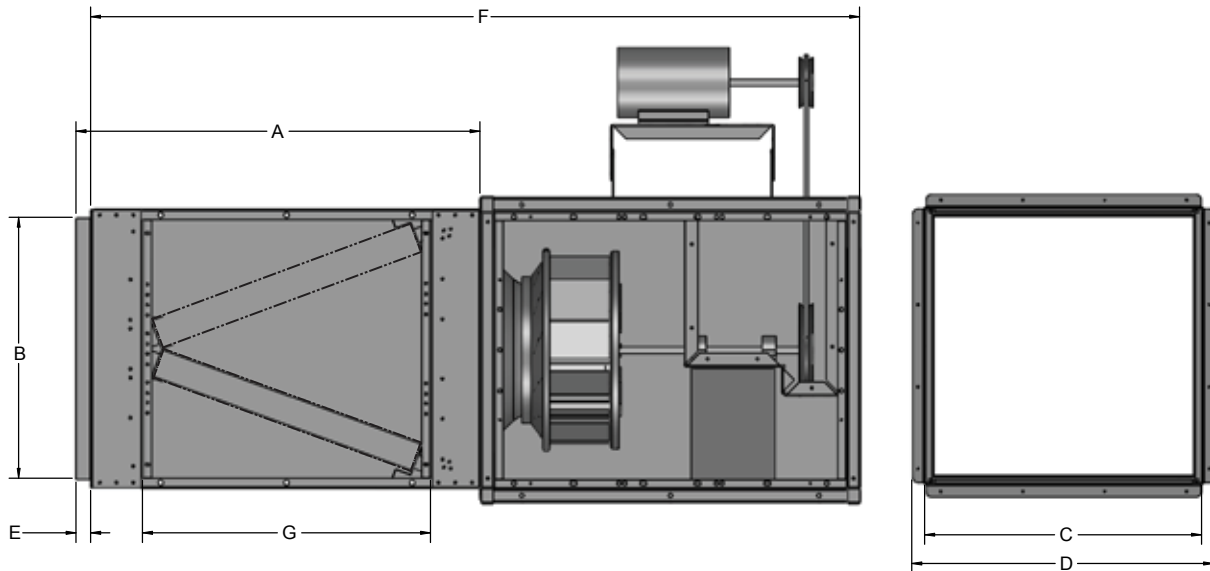

## Filter Box Dimensions (Direct)

Model	A	B	C	D	E	F	G	Filters Qty / Size	
SX085	26.96	12.67	13.9	15.75	1	42.22	20.89	1	14 x 20
SX095	26.96	12.67	13.9	15.75	1	50	20.89	2	14 x 20
SX115	28.87	18.67	19.8	21.64	1	55	20.37	2	20 x 20

## Filter Box Dimensions (Belt)

Model	A	B	C	D	E	F	G	Filters Qty / Size	
SX100BC	26.96	12.67	13.9	15.75	1	49.97	20.89	2	14 x 20
SX120 SX125BC	34.7	18.67	19.8	21.64	1	60.71	26.32	3	20 x 25
SX155 SX165BC	30.08	24.78	25.81	27.66	1	62.08	21.33	4	20 x 25
SX205BC	35.08	24.78	25.81	27.66	1	67.08	26.28	4	25 x 25
SX225BC	35.22	29.46	30.41	32.98	1.5	69.73	25.95	4	16 x 25
								4	14 x 25
SX275BC	36.05	36.71	38.47	41.04	1.5	78.55	25.71	4	25 x 25
								4	14 x 25
SX335BC	37.35	45.21	46.87	49.44	1.5	83.86	25.91	15	16 x 25
SX420BC	38.78	55.57	57.17	59.74	1.5	91.28	25.27	10	16 x 25
								5	25 x 25

# MOTOR AVAILABILITY

## Green Plus Electronically Commutated Motor

The Green Plus (GP) option utilizes EC motors to provide significantly greater efficiency, flexibility, and controllability over standard direct drive permanent split capacitor (PSC) motors. Using the included potentiometer, the Green Plus motors can be turned down to as low as 80% the max operating speed while maintaining 90% efficiency through the operating range. Additionally, the Green Plus can accept 0-10V input to tie to building management systems, not only allowing for savings in direct fan energy consumption but reducing the exhaust of conditioned air during off peak hours as well. All Green Plus motors come in open enclosure or totally enclosed for usage with 115V-208V/230V or 460V, single phase or three phase, 50/60 Hz applications.



Model	HP	1 - Phase			3 - Phase
		ODP 110-120, 277V	TE 110-120V	TE 208-480V	TE 230-460v
SX085V/SCGP	1/6	-	X	X	-
SX085RCGP	1/3	X	-	-	-
SX085RCGP	1/6	-	X	X	-
SX85QCGP	1/4	-	X	X	-
SX095V/S/RCGP	1/3	X	-	-	-
SX095V/S/RCGP	1/6	-	X	X	-
SX095QCGP	1/3	X	-	-	-
SX095QCGP	1/4	-	X	X	-
SX115VCGP	1/3	X	-	-	-
SX115VCGP	1/6	-	X	X	-
SX115SCGP	1/3	X	X	X	-
SX115RCGP	1/2	X	X	X	-
SX115Q1CGP	1/2	X	X	X	-
SX115Q2CGP	3/4	X	X	X	-
SX120SGP	1/2	-	X	X	-
SX125RGP	1 1/2	-	X (1)	-	X
SX125KGP	1 1/2	-	X (1)	-	X
SX125HSGP	1/2	-	X	X	-
SX125HRGP	3/4	-	-	X	-
SX155TGP	1 1/2	-	X (1)	-	X
SX155RGP	2	-	-	-	X
SX165TGP	1 1/2*	-	-	-	X

(1) Fan input power is single phase to motor speed controller, actual motor is 3 - phase.

\* Non-programmed motor horsepower is 2 HP.

# MOTOR SELECTION

After choosing a fan model from the Direct Drive or Belt Drive Performance Data sections, it is important to review the motor availability charts in this section before specifying electric motors for your particular needs. Factors which influence the selection process are discussed below.

## Electric Power Considerations

First, determine the nature of the electric power feeding the motor. Is it single phase or three phase power? Next, determine the required line voltage. Is it 115V, 230V, or 460V? Applications using 277V will require a transformer. If your HVAC application is in the U.S., the frequency of the alternating current will be 60 Hz. All of North America and most of Central and South America use 60 Hz as does Saudi Arabia. Most other countries in the world use 50 Hz.

## Environmental Considerations

Standard motors supplied with fans are called Open Drip Proof (ODP) motors. Other types of motors may be required to meet specific field conditions; high temperature (50°C) or Totally Enclosed (TE) are two examples. Hazardous environments require Explosion Proof motors. Standard Explosion Proof motors are rated for Class 1, Group D, Div. 1 and Class II, Groups F and G, Div. 1 applications. Motors for other classes and groups may also be available. Please consult your local PennBarry representative for information.

## Unit Mounting

The Centrix's versatile design allows for mounting at a variety of angles. When unit positioning necessitates motor mounting to the side of the unit, Pennbarry recommends motors up to 2 HP. Selection of a higher HP motor may void warranty.

## Variable Speed Motor Control

PennBarry offers Lek-Trol™ solid state controllers to alter the high speed of most direct drive motors by as much as 50%. If variable speed is required, check the Lek-Trol™ availability table on page 8 to verify that controllers exist for the fan model selected. Remember, Lek-Trol™ controllers are currently only available for direct drive motors. Motors suitable for use with field supplied Variable Frequency Drives can be supplied for belt drive models. Contact your local PennBarry representative.

## High-Efficiency Motors

High-efficiency motors that comply with the requirements of the Energy Policy Act of 1992 are available.

## Direct Drive Motor Ability

The following chart lists the various motor options available for each of the direct drive fan models. Once a fan model is selected, this chart can be used to determine if a suitable motor is available. (If not, another selection may have to be made from the fan performance charts). Look under the nominal RPM heading to determine which fans have 2-speed and 3-speed motors. Centrex Inliner direct drive models (except size 085) are available with single and multi-speed motors. Multi-speed motors are designated V (1050 RPM), S (1300 RPM), and R (1550 RPM) (SX085R is an exception being a single speed motor). Q, Q1, Q2 (1725/1760 RPM) are single speed motors. A single Centrex Inliner fan may be suitable for several requirements by a simple wiring change. This feature provides flexibility for a variety of reasons, including energy savings, future expansion or unexpected field variations

## Direct Drive Motor Options

Model	Nominal RPM				1 Phase									3 Phase				
	1050 V	1300 S	1550 R	1725 Q	115 Volts			200 - 240 Volts						200 - 460 Volts				
					Open Drip Proof	Totally Enclosed	Expl. Proof (4)	Open Drip Proof	Totally Enclosed	50 hz	50°C	Expl. Proof (4)	Open Drip Proof	Totally Enclosed	50 hz	50°C	Expl. Proof (4)	
SX085RC					-	yes	-		yes	yes	yes	-		-	-	-	-	
SX095V/S/RC	X	X	X		yes	yes (1)	-		yes (1)	yes (1)	yes (1)	-		-	-	-	-	
SX095QC				X	yes	yes	yes		yes	yes	yes	yes (5)		-	-	-	yes (6)	
SX115V/S/RC	X	X	X		yes	yes (1)	-	Use TE	yes (1)	yes (1)	yes (1)	-		-	-	-	-	
SX115Q1C				X (3)	yes	-	-	Motors	-	-	-	-		-	-	-	-	
SX115Q2C				X	yes	yes	yes		yes	yes	yes	yes (5)		-	-	-	yes (6)	

- (1) High speed only.
- (2) 200V - 240V, 380V, 415V, 460V
- (3) Nominal 1650 RPM
- (4) Cls. I, Grp. D, Div. I/Cls. II, Grp. F & G, Div. I. Not available with 50 Hz.
- (5) 230V only. Not available in 200V or 208V
- (6) 230V and 460V only.

**Caution:** Hazardous environments require that fans be built for such service. (Care must be taken regarding the location of these fans in the duct run and surrounding environment). All belt drive inline fans, regardless of manufacturer, inherently leak. Additionally, the flat access panels supplied are not designed to provide air-tight service. Duct systems, except those fully welded, are not air-tight.

# DIRECT DRIVE | DIMENSIONS

## SX85 - 125H

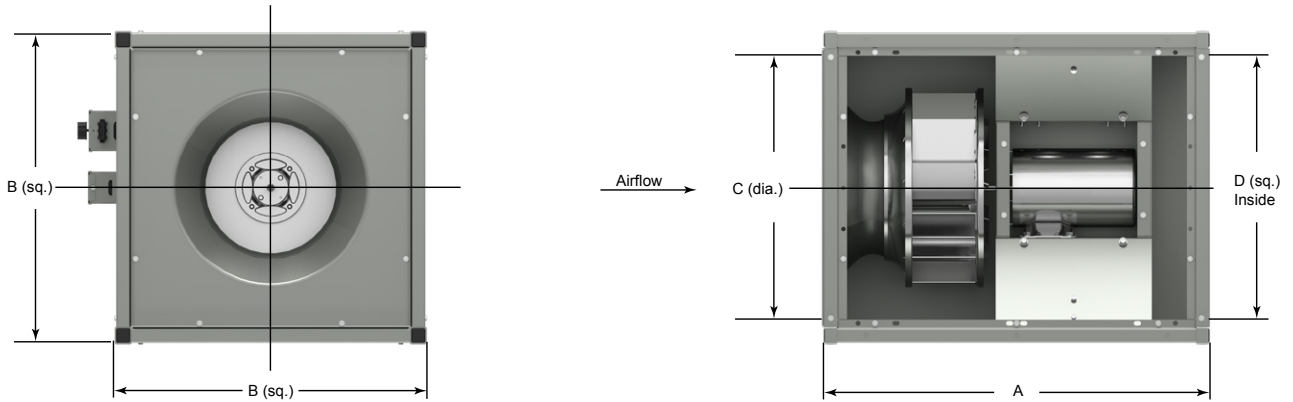

Model	A	B (sq.)	C (dia.)	D (sq.)	Est. Ship Weight
SX085	16 1/8	15 3/4	11 3/4	13 3/4	35 lbs
SX095	24 1/8	15 3/4	11 3/4	13 3/4	50 lbs
SX115	27 1/4	21 3/4	14 1/2	19 3/4	70 lbs
SX-120	27.22	22.00	19.50	18.54	74 lbs
SX-125H	27.22	22.00	19.50	18.54	90 lbs

All dimensions in inches

## SX120 - SX165

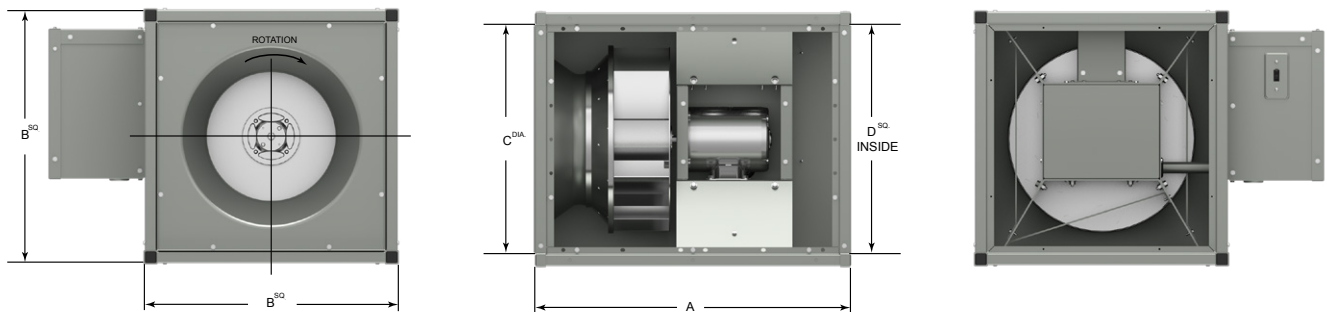

Model	A	B	C	D	Est. Ship Weight
SX-125	27.22	22.00	19.50	18.54	90 lbs
SX-155	33.00	28.00	25.63	24.54	137 lbs
SX-165	33.00	28.00	25.63	24.54	144 lbs

All dimensions in inches

# BELT DRIVE | DIMENSIONS

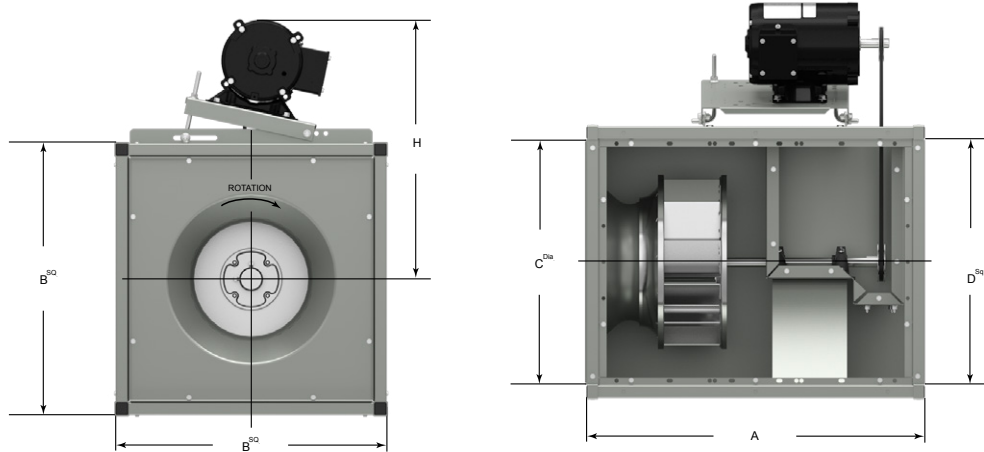

Model	A	B <sup>Sq</sup>	C <sup>Dia</sup>	D <sup>Sq</sup>	H	Damper Size (Sq)	Max Motor FrameSize	Est. Ship. Weights (galv/alum)
SX100BC	24	16	11 7/8	13 7/8	22	16	213T	63/43 lbs.
SX120BC	27	22	14 1/2	19 7/8	23 1/8	22	213T	74/51 lbs.
SX125BC	27	22	16 1/4	19 7/8	23 1/8	22	213T	90/62 lbs.
SX125BHC	27	22	16 1/4	19 7/8	23 1/8	22	213T	90/62 lbs.
SX155BC	33	28	18 7/8	25 7/8	26 1/2	28	213T	137/97 lbs.
SX165BC	33	28	18 7/8	25 7/8	26 7/8	28	213T	144/99 lbs.
SX205BC	33	28	21	25 7/8	26 7/8	28	213T	152/104 lbs.
SX205BHC	33	28	21	25 7/8	26 7/8	28	213T	152/104 lbs.
SX225BC	36	33 1/4	26	30 1/4	30 1/2	33 1/4	213T	245 lbs.
SX225BHC	36	33 1/4	26	30 1/4	30 1/2	33 1/4	213T	245 lbs.
SX275BC	44	40 1/2	30 7/8	37 1/2	39	40 1/2	213T	415 lbs.
SX335BC	48	49 1/2	37 7/8	46 1/2	44 1/4	49 1/2	215T	525 lbs.
SX420BC	44	60	44	57	49 1/2	61 1/2	215T	725 lbs.

All dimensions are in inches

Model	Galv. Side Panel	Galv. Corner Post	Alum. Side Panel	Alum. Corner Post
SX100-205BC	20 gauge	16 gauge	0.051"	0.064"
SX225-335BC	20 gauge	14 gauge	NA	NA
SX420BC	14 gauge	14 gauge	NA	NA

# FAN SELECTION

## Model

SX = Centrifugal Inline Fan

## Construction

Application Flow (CFM) <enter value>	Tag <enter value>	420
Application Static Pressure (inwc) <enter value>	Size 085 095 100 115 120 125 155	Drive Type B = Belt D = Direct
Application E = Exhaust / Relief S = Supply / Intake	165 205 225 275 335	Fan RPM <#####>

## Motor

<p><b>Motors and Drives</b></p> <p>F = Factory mounted L = Less motor less drive X = Special</p> <p><b>Motor Enclosure</b></p> <p>0 = None 1 = TE w/Overload* 2 = TE w/o Overload** 3 = ODP w/Overload 4 = ODP w/o Overload 5 = EXP C2D1 7 = TE w/ SGR X = Special</p> <p>* Default for motor efficiency "G". ** Default for motor efficiency "M".</p> <p><b>Efficiency</b></p> <p>M = Gplus (Permanent Magnet) G = Gplus (ECM) S = Standard P = Premium</p> <p><b>Horsepower</b></p> <p>0.050 = 1/20    0.05 0.083 = 1/12    0.08 0.167 = 1/6     0.16 0.250 = 1/4     0.25</p>	<p>0.333 = 1/3    0.33 0.500 = 1/2    0.50 0.750 = 3/4    0.75 01.00 = 1       1 01.50 = 1 1/2   1.5 02.00 = 2       2 03.00 = 3       3 05.00 = 5       5 07.50 = 7 1/2   7.5 10.00 = 10      10 15.00 = 15      15 20.00 = 20      20 25.00 = 25      25 X = Special     X</p> <p><b>Voltage/Phase/Cycle</b></p> <p>4 = 460V/1PH/60HZ* B = 110V/1PH/50HZ* C = 115V/1PH/60HZ D=120V/1PH/60HZ* E = 190V/3PH/50HZ* F = 208V/1PH/60HZ G = 208V/3PH/60HZ H = 220V/1PH/50HZ* J = 220V/3PH/50HZ* K = 230V/1PH/60HZ L = 230V/3PH/60HZ M = 240V/1PH/50HZ* N = 240V/3PH/50HZ*</p>	<p>P = 277V/1PH/60HZ*# Q = 380V/3PH/50HZ* R = 380V/3PH/60HZ* S = 400V/3PH/50HZ* T = 415V/3PH/50HZ* U = 440V/3PH/50HZ* V = 460V/3PH/60HZ W = 480V/3PH/60HZ* X = Special Y = 575V/3PH/60HZ * Non-standard offering subject to longer lead times and price adjustment #277V applications require a transformer</p>
--	---	---

# FAN SELECTION

## Nominal Motor Tap

0 = None  
K = 1650 RPM (Q1C)  
Q = 1725 RPM (QC,Q2C)  
R = 1550 RPM (RC)  
S = 1300 RPM (SC)  
T = 1140 RPM (TC)  
V = 1050 RPM (VC)

## Wheel Width (for centrifugal fans)

0 = Standard  
H = High pressure

## Controllers

0 = None  
A = 0-10V output potentiometer  
1 = Lek-Trol SCR speed controller (mounted)  
2 = Lek-Trol SCR speed controller (loose)  
3 = Multi speed controller, iQ MS (ECM only)  
4 = iQ-IPCM -no power supply (ECM only)  
5 = iQ-IPCM with 115V/230V power supply (ECM only)  
6 = iQ-IPCM with 277V power supply (ECM only)  
7 = Provided by others  
M = On board motor speed controller // IP22 or less\*  
V = VFD (belt drive only)  
Note: VFD can be ordered separately  
\* only available with efficiency "M".

## Service Switches and ITW\*

0 = None  
1 = NEMA 1 ITW only  
3 = NEMA 3R ITW only  
A = NEMA 1 - loose\*\*  
C = NEMA 1 - mounted and wired  
D = NEMA 3R - loose  
F = NEMA 3R - mounted and wired  
G = NEMA 4 - loose  
N = NEMA 7 - loose  
Q = NEMA 9 - loose  
X = Special  
\* ITW - Internal wiring not provided on explosion proof motors

## Switches / Sensors

0 = None  
A = Airminder switch (time delay)  
B = Airminder + firestat  
F = Firestat switch

## Switches / Sensors

0 = None  
A = Airminder switch (time delay)  
B = Airminder + firestat  
F = Firestat switch

## Paint/Coating

0 = None  
F = Epoxy powder coat (light gray)  
G = Epoxy powder coat with UV protection (gray)  
K = Phenolic epoxy powder coat (gray)  
L = Phenolic epoxy powder coat with UV protection (gray)  
N = Polyester powder coat\*  
X = Special  
\* Colors only available in Polyester Powder Coat

## Paint Color\*

00 = None  
50 = Chrome green  
55 = Pale green  
56 = Dove gray (PPC standard)  
61 = White  
63 = Oxford beige  
65 = Dover white  
66 = Desert tan  
70 = Black  
73 = Smoke gray  
77 = Brick red  
79 = Peppercorn  
81 = Pale brown  
83 = Chocolate brown  
85 = Timeless bronze  
94 = Charcoal  
X = Special  
\* Colors only available for polyester powder coat

## Special Construction

A = Aluminum housing (AMCA B)  
G = Galvanized housing (AMCA C)  
S = Spark resistance (AMCA B) + 1" dual density fiberglass sound insulation  
U = Galvanized housing (AMCA C) +1" dual density fiberglass sound insulation

## Weather/Motor Cover

0 = None  
C = Weather/motor cover

## Extended Lube Lines

0 = None  
L = Extended lube lines

## Guard/Screen

0 = None  
N = Inlet guard  
T = Inlet and outlet guard  
U = Outlet Guard

## Damper

0 = None  
D = Damper  
AN = Alum. parallel blade damper  
A1 = Alum. parallel blade damper, motorized 115V  
A2 = Alum. parallel blade damper, motorized 230V  
A3 = Alum. parallel blade damper, motorized 460V  
BN = Steel parallel blade damper  
B1 = Steel parallel blade damper, motorized 115V  
B2 = Steel parallel blade damper, motorized 230V  
B3 = Steel parallel blade damper, motorized 460V  
X = Special

## Transformer

0 = None  
B = 277Vx115V  
X = Special

## Spare Belt(s)

0 = None  
1 = 1 spare set  
2 = 2 spare set



# FAN SELECTION

## Vibration

- 0 = None
- 1 = Rubber in shear floor
- 2 = Rubber in shear hanger
- 3 = Floor flex pads
- 4 = Spring floor
- 5 = Spring hanger

## Support Channels

- 0 = None
- 1 = Support channels

## Flange/Companion Flange Kit

- 0 = None
- 1 = Inlet flange

## Filters

- 0 = None
- 1 = 1" Washable Aluminum Filters\*
- 2 = 2" Washable Aluminum Filters\*
- 3 = 1" Disposable Pleated Filters\*
- 4 = 2" Disposable Pleated Filters\*
- \* SX includes a filter box

## Drive Kit Option

- 0 = None
- A = Adjustable drive kit
- L = Life safety
- X = Special

# PENNBARRY PRODUCT SOLUTIONS

---



## Commercial

- Roof & wall exhaust centrifugal fans
- Ceiling, wall, & inline centrifugal fans
- Roof supply centrifugal fans
- Square & round centrifugal fans
- Wall mounted axial fans
- Hooded roof axial fans
- Upblast roof axial fans
- Gravity ventilators
- Roof curbs



## Industrial

- Freestanding centrifugal fans
- Industrial & material handling fans
- Tubular centrifugal inline fans
- Mixed flow centrifugal fans
- Plug & plenum fans
- Wall mounted propeller fans
- Tube axial fans
- Vane axial fans
- Bifurcator fans
- Lab exhaust



## Kitchen ventilation

- Make-up air units
- Exhaust fans



## Energy recovery

- Outdoor units
- Indoor units

PennBarry is proud to be your preferred manufacturer of commercial and industrial fans and blowers. Learn how PennBarry can assist you in your next application by contacting your PennBarry Representative or visiting us on the web at [www.pennbarry.com](http://www.pennbarry.com)

PennBarry | [www.pennbarry.com](http://www.pennbarry.com) | [pennbarrysales@pennbarry.com](mailto:pennbarrysales@pennbarry.com) | Tel 972 212 4700 | Fax 972 212 4702

PennBarry reserves the right to make changes at any time, without notice, to models, construction, specifications, options and availability. This document illustrates the appearance of PennBarry products at the time of publication. View the latest updates on the PennBarry website.

© 2018 PennBarry. All rights reserved. CENTREX JUNE 2019.



PENNBARRY™