

Linea

Centrifugal Roof Exhauster Direct & Belt Drive

OPERATION & MAINTENANCE MANUAL



PENNBARRY™

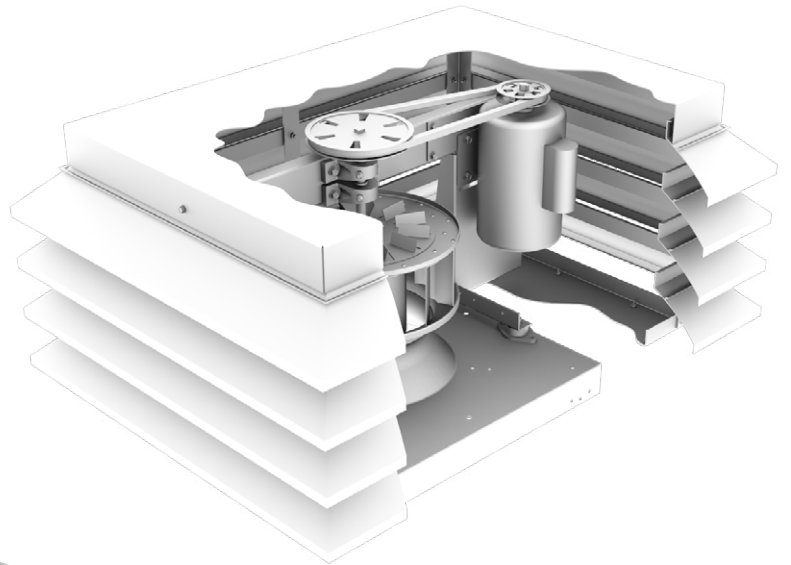

IMPORTANT! Read before proceeding!

Please read and save these instructions. Read carefully before attempting to assemble, install, operate or maintain the product described. Protect yourself and others by observing all safety information. Failure to comply with instructions could result in personal injury and/or property damage! Retain instructions for future reference.

TABLE OF CONTENTS

INTRODUCTION	3
INSTALLATION	4
START-UP AND OPERATION	5-6
MAINTENANCE	7-9
TROUBLESHOOTING CHECKLIST	10

INTRODUCTION

Receiving and Handling

PennBarry fans are carefully inspected before leaving the factory. When the unit is received, inspect the carton for any signs of tampering. Inspect the unit for any damage that may have occurred during transit and check for loose, missing or damaged parts. Mishandled units can void the warranty provisions. If units are damaged in transit, it is the responsibility of the receiver to make all claims against the carrier. PennBarry is not responsible for damages incurred during shipment.

Avoid severe jarring and/or dropping. Handle units with care to prevent damage to components or finishes. If the unit is scratched due to mishandling, the protective coating may be damaged. Incorrect lifting may damage the fan and void the warranty.

Storage

Long-term storage requires special attention. Store units on a level, solid surface, preferably indoors. If outside storage is necessary, protect the units against moisture and dirt by encasing the cartons in plastic or in some similar weatherproof material. Periodically inspect units and rotate wheels to spread bearing lubricant. Failure to rotate wheels results in reduced bearing life and may void the manufacturer's warranty. If the unit will be stored for an extended time, remove belts. Belts which remain under tension in a stationary position for extended periods are likely to have a reduced operating life.

Unpacking

Place the carton in an upright position and remove the staples or use a sharp (knife edge) tool to carefully cut or scribe the sealing tape on both sides at the top of the carton. Open carton flaps. Remove any cardboard and wooden filler pieces, as well as loose components or accessories shipped with the unit.

Carefully remove the unit from the carton. Inspect the unit for any damage that may have occurred during transit and check for loose, missing or damaged parts.

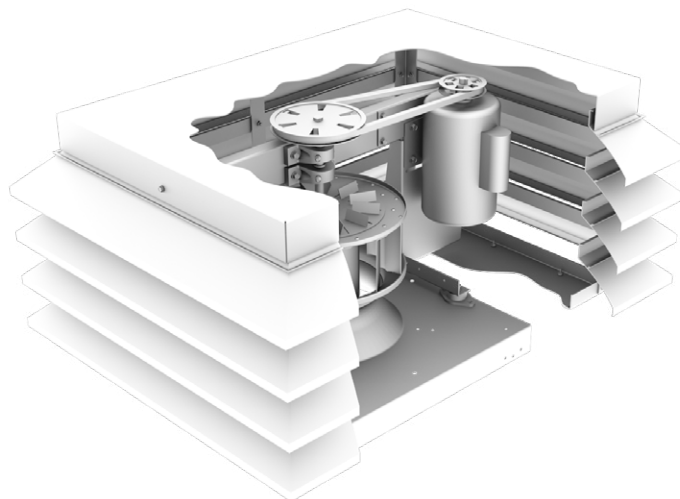

INSTALLATION

INSTALLING THE LOUVER DAMPERS

When required, install dampers prior to mounting the unit on the curb or frame. Secure dampers to the inside of the curb without undue twisting, which may distort the damper frame. Damper frame must be reasonably level on all sides. Check for free operation. If dampers are motor operated type, ascertain that the proper voltage is impressed on motor terminals.

POSITIONING AND RUNNING POWER LINES

Power is normally brought from within the building and placed inside one corner of the curb. Feed power line through the clearance hole provided in the damper if furnished, if not clearance hole is provided, remove a corner of the lower damper (with a shear cutter or other instrument), and in turn through the electrical conduit hole provided in the base of the exhauster (feed through rubber grommets on smaller units). If local codes require special electrical wire of unusually large size, then remove and discard the electrical conduit (or grommets), making sure to protect the wires from sharp edges.

INSTALLING THE FAN

For access to motor and drive assembly, simply remove or lift access hood and make necessary power connections to the motor (through service switch if required). Provide a generous amount of slack in power line between motor and service switch to allow for motor deflections and to permit movement of motor for belt tension adjustments.

ANCHORING OR SECURING THE UNIT

Whenever possible, anchor the fan by fastening through the vertical portion of the mounting flange. The type of fastener depends upon curb construction, and using two fasteners per side constitutes adequate anchoring under normal conditions. If code or specification prescribes fastening through the top (horizontal portion) of the mounting flange, use neoprene or lead washers under the head of each fastener to prevent water leaks.



Guy down large units installed in areas subject to high winds or unusual field conditions.

To complete the re-assembly of the unit, secure hood to frame by replacing all spacers, washers and nuts exactly as they were found prior to removal. The unit is now ready for service. Apply power and check rotation as indicated by arrow in motor compartment. The rotation of all centrifugal ventilators is counterclockwise when viewing the unit from above the motor compartment.

START-UP AND OPERATION

MECHANICAL NOISE CHECKLIST

The fan has been checked at the factory prior to shipment for mechanical noises. If installed properly, it will provide quiet ventilation. If noises should develop, check the suggestions below as a guide toward remedying the cause.

- Check rotating members for adequate clearance.
- Check for proper belt tension and pulley alignment.
- Check installation and anchoring.
- Check fan bearings.

If your unit is exhausting over a hood which uses filters, clean the filters frequently. Dirty or clogged filters tend to increase static resistance and cause a reduction in airflow.

Carefully inspect the unit before start-up. All motor bearings should be properly lubricated, and all fasteners should be securely tightened. Rotate blower wheel by hand to ensure free movement. Make sure the inlets and approaches to the exhauster are clean and free from obstruction. To ensure maximum air movement, adequate supply air must be available.

Rough shipping or handling may cause the wheel or propeller to move away from the venturi inlet. That condition can cause the fan to move less air. If that occurs, loosen set screws and adjust the impeller closer to the inlet. Retighten all hardware securely.

Check condition of belts and the amount of tension prior to start-up. When it becomes necessary to adjust belt tension, do not overtighten as bearing damage will occur. Recommended belt tension should permit deflection of 1/64 per inch of span of the belt on each side of the belt measured halfway between the pulley centerline. Exercise extreme care when adjusting belts as not to misalign the pulleys. Any misalignment will cause a sharp reduction in belt life and produce squeaky, annoying noises. On units equipped with two or three groove pulleys, adjust all belts with equal tension.

Figure 1: Pulley Alignment & Tension

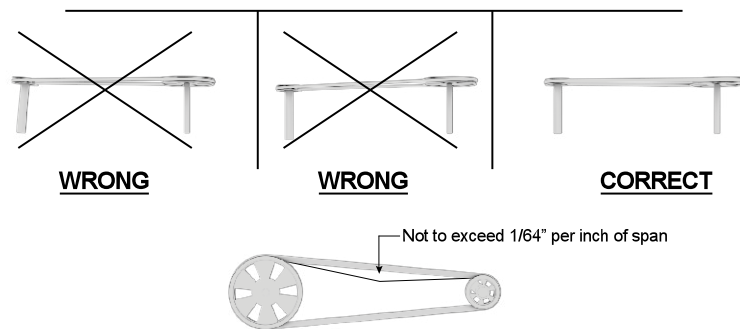

Whenever belts are removed or installed, never force belts over pulleys without loosening motor first to relieve belt tension.

START-UP AND OPERATION

Before applying power to the motor, check the following:

- a. Check line voltage with motor nameplate.
- b. On single phase motors, set-up the terminal blocks in accordance with the nameplate instructions (or wiring diagram). The set-up must match the line voltage.
- c. If the motor is three phase, group and connect the winding leads as shown on the wiring diagram. The line voltage must correspond with proper grouping of motor leads.
- d. On two speed motors, follow the wiring diagram explicitly, or serious motor damage will occur.
- e. Activate the blower and allow it to operate.
- f. Carefully check the rotation of the wheel to ensure operation in the proper direction.



Incorrect rotation overloads motor severely and results in serious motor damage. To change rotation of three phase units, simply interchange any two of the three line leads. On single phase units, change the terminal block set-up following the wiring diagram.

- g. Check that bearing temperatures are not excessively hot.
- h. Check that all bolts and hangers are secure after one (1) hour of continuous operation.

NOTE: Take care to follow all local electrical, safety and building codes. Follow provisions of the National Electrical Code as well as the Occupational Safety and Health Act

Always disconnect power source before working on the unit.

Guard and protect all moving parts.

All motors are checked prior to shipment. However, if motor defects should develop, prompt service can be obtained from the nearest authorized service station of the motor manufacturer under the warranty. Exchange, repair or replacement will be provided on a no charge basis if the motor is defective within the warranty period. Motor guarantee is void unless overload protection is provided in motor wiring circuit.

MAINTENANCE

Do not attempt maintenance on a fan until the electrical supply has been completely disconnected. Lubrication is a primary maintenance responsibility. Check all bearings periodically. Inspect belts for tightness. If the fan is installed in a corrosive or dirty atmosphere, periodically clean the centrifugal wheel, inlet, motor housing and other moving parts.

FAN SHAFT LUBRICATION

Fan shaft bearing pillow blocks are furnished in either the pre-lubricated sealed-for-life type or the greasable type depending on what was ordered. The pre-lubricated type requires no servicing for 7 to 10 years of normal use, and the greasable type are factory greased, eliminating the need for greasing initially. Follow the lubricating schedule recommended by the factory. This practice should not supersede any safety considerations.



Use low pressure grease guns only. High pressure guns tend to blow out or unseat bearing seals, leaving the bearing open to collect grime, dust and foreign particles.

LUBRICATION SCHEDULE

Always follow the bearing manufacturer's recommended lubrication schedule. If none is available, use the following general schedule:

- Under average conditions where ambient temperatures do not exceed 120°F, lubrication is required 1 to 2 times a year.
- Under dirt laden atmosphere where there is a temperature range of 120°F to 150°F, lubrication is required from 3 to 6 times a year.
- Under extreme temperature conditions and extremely dirty atmospheres, lubrication should be scheduled at least once or twice a month.
- Belt driven units maximum temperature should not exceed 160°F. Direct driven models have temperature range stamped on motor.

Table 1: Recommended Lubricants

Manufacturer	Product	Temp. Range
BP	LG-#P-1	Below 32°F (0°C)
Gulf	Gulfcrown EP-1	
Imperial Oil	Unirex EP-1	
Shell	Alvania R-1	
BP	Energrease, MPMK11	32°F to 150°F (0°C to 66°C)
Gulf	Gulfcrown EP-2	
Imperial Oil	Unirex EP-2	
Shell	Alvania R-3	
Sun Oil	Sun Prestige 42	
Texaco	Regal AFB2	

MOTOR LUBRICATION

In general, standard motors are furnished with prelubricated, sealed-for-life ball bearings which require no lubrication for 7 to 10 years of normal service. Where motors have been ordered with greasable bearings, these bearings are factory lubricated and require no attention for one year under normal conditions. If grease relief fittings are provided, remove them when performing maintenance to allow grease to flow out. Whenever possible, apply grease while the motor is running. This practice should not supersede any safety considerations. **DO NOT OVER GREASE**, as most lubricants deteriorate motor windings thereby reducing motor life and presenting a fire hazard.

MAINTENANCE

Hidden Danger

In addition to the normal dangers of rotating machinery, fans present an additional hazard in their ability to suck in not only air but loose material as well. Solid objects can pass through the fan and be discharged by the impeller as potentially dangerous projectiles. Therefore, screen intake to ductwork, whenever possible, to prevent the accidental entrance of solid objects. Never open access doors to a duct system with the fan running.

When starting the fan for the first time, completely inspect the ductwork and interior of the fan (with the power locked off), to make certain there is no foreign material which can be sucked into or blown through the ductwork.

Where the fan is accessible to untrained personnel or the general public, use maximum safety guards, even at the cost of some performance loss.



Unprotected fans located less than 7" above the floor also require guarding as specified in the Occupational Safety and Health Act (OSHA).

Centrifugal fans may be connected directly to ductwork which will prevent contact with the internal moving parts, but when the inlet or outlet is exposed, install a suitable guard. PennBarry recommends the use of guards on all exposed non-ducted fans, ceiling and wall mounted.

Special Purpose Systems

Environments that are explosive, corrosive, subject to high temperatures, etc. may require special construction, inspection and maintenance. It is necessary to observe the fan manufacturer's recommendations and limitations concerning the type of material to be handled by the fan and its application to special conditions.

MAINTENANCE

Parts List

If replacing parts, do so with properly selected components which duplicate the original parts correctly. Incorrectly sized shafts, belts, pulleys, centrifugal wheels, etc. can damage the fan.

1. Formed Aluminum Roof
2. Extruded Aluminum Blades
3. Base Inlet Venturi
4. Electrical Motor
5. Centrifugal Fan Wheel
6. Vibration Eliminators
7. Structural Steel Support Angles
8. Motor and Bearing Frame (Belt Drive)
9. Belt and Pulleys (Belt Drive)
10. Bearings (Belt Drive)
11. Motor Support Plate (Direct Drive)

Figure 2

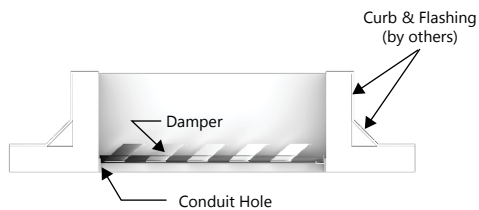
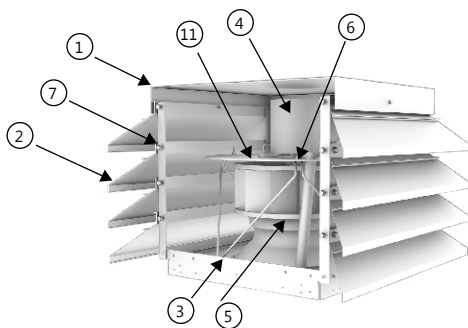
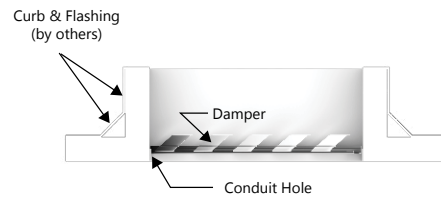
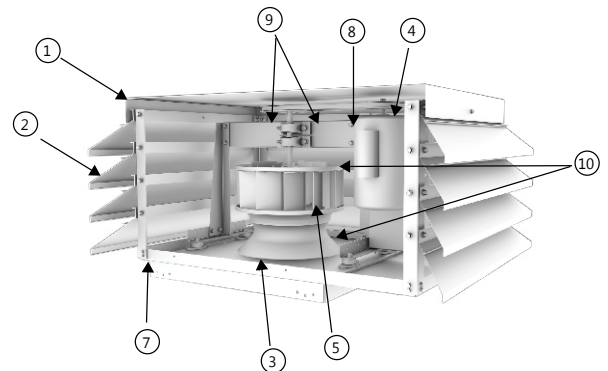

Figure 3



TROUBLESHOOTING CHECKLIST

Symptom	Possible Cause(s)	Corrective Action
Excessive Noise	1. Defective or loose motor bearings	1. Replace motor with same frame size, RPM, HP
	2. Ventilator base not securely anchored	2. Reset properly
	3. Loose or unbalanced wheel/propeller	3. Tighten screws, remove build-up, balance wheel/propeller
	4. Misaligned pulleys or shaft	4. correct alignment
	5. Loose or damaged wheel/propeller	5. Replace wheel/propeller
	6. Wheel running in wrong direction	6. Reverse direction
Fan Inoperative	1. Blown fuse or open circuit breaker	1. Replace fuses or circuit breaker
	2. Loose or disconnected wiring	2. Shut off power and check wiring for proper connections
	3. Defective motor	3. Repair or replace motor
	4. Broken belts	4. Replace belts
Insufficient Airflow	1. Open access doors or loose sections of ducts	1. Check for leakage
	2. Clogged filters	2. Clean filters
	3. Operation in wrong direction	3. Correct rotation of wheel/propeller
	4. Insufficient make-up air direction	4. Add make-up fan or louver opening
Water Leaking Into Ductwork or Collection of Grease Under Fan	1. Fan installed with slope in the wrong direction	1. Slope should be fitted in the direction of the drainage opening or grease collection box and drain spout
	2. Clogged drain spout	2. Clean drain spout
	3. Cooling tube or motor dome top removed	3. Install new cooling tube with gasket and dome top
	4. Grease container full	4. Empty grease box
Motor Overheating	1. Belt slippage	1. Adjust tension or replace bad belts
	2. Overvoltage or under voltage	2. Contact power supply company
	3. Operation in wrong direction	3. Reverse direction of motor
	4. Fan speed too high	4. Slow down fan by opening variable pitch pulley on motor shaft
	5. Incorrect motor (service factor 1.0, low ambient temperature)	5. Replace motor with correct open, NEMA service factors (1.15 or higher) with 40 degrees ambient
	6. Blocked cooling tube or leaky gasket	6. Remove blockage and seal cooling tube in place
	7. Insufficient airflow to kitchen hood fan operating on low speed with kitchen in full operation	7. Check airflow under hood and adjust kitchen equipment output
	8. Undersized motor	8. Check motor ratings with catalog speed and air capacity chart

Note: Care should be taken to follow all local electrical, safety and building codes. Provisions of the National Electric Code (NEC), as wells as the Occupational Safety and Health Act (OSHA) should be followed.



PENNBARRY™

PennBarry is proud to be your preferred manufacturer of commercial and industrial fans and blowers. Learn how PennBarry can assist you in your next application by contacting your PennBarry Representative or visiting us on the web at www.pennbarry.com.

PennBarry | www.pennbarry.com | pennbarrysales@pennbarry.com | tel: 972.212.4700 | fax: 972.212.4702

PennBarry reserves the right to make changes at any time, without notice, to models, construction, specifications, options and availability. This manual illustrates the appearance of PennBarry products at the time of publication.

View the latest updates on the PennBarry website.

© 2018 PennBarry. All Rights Reserved. Revised AUGUST 2018