



DEPARTMENT OF REGULATORY AND ECONOMIC RESOURCES (RER)
BOARD AND CODE ADMINISTRATION DIVISION

NOTICE OF ACCEPTANCE (NOA)

MIAMI-DADE COUNTY
PRODUCT CONTROL SECTION
11805 SW 26 Street, Room 208
Miami, Florida 33175-2474
T (786) 315-2590 F (786) 315-2599
www.miamidadegov/economy

Air System Components, Inc. dba PennBarry
605 Shiloh Road
Plano, TX 75074

SCOPE:

This NOA is being issued under the applicable rules and regulations governing the use of construction materials. The documentation submitted has been reviewed and accepted by Miami-Dade County RER-Product Control Section to be used in Miami Dade County and other areas where allowed by the Authority Having Jurisdiction (AHJ).

This NOA shall not be valid after the expiration date stated below. The Miami-Dade County Product Control Section (In Miami Dade County) and/or the AHJ (in areas other than Miami Dade County) reserve the right to have this product or material tested for quality assurance purposes. If this product or material fails to perform in the accepted manner, the manufacturer will incur the expense of such testing and the AHJ may immediately revoke, modify, or suspend the use of such product or material within their jurisdiction. RER reserves the right to revoke this acceptance if it is determined by Miami-Dade County Product Control Section that this product or material fails to meet the requirements of the applicable building code.

This product is approved as described herein and has been designed to comply with the Florida Building Code, including the High Velocity Hurricane Zone.

DESCRIPTION: Model PHHW Aluminum Penthouse Louver System

APPROVAL DOCUMENT: Drawing No. **60-022497-00D**, titled "PHHW Penthouse", sheets 1 through 11 of 11, dated 12/04/2017, prepared by Air System Components, Inc. dba PennBarry, signed and sealed by Jeffrey D. Smith, P.E. on 08/16/2022, bearing the Miami-Dade County Product Control revision stamp with the Notice of Acceptance number and approval date by the Miami-Dade County Product Control Section.

MISSILE IMPACT RATING: Large and Small Missile Impact Resistant

LABELING: Each unit shall bear a permanent label with the manufacturer's name or logo, city, state, model/series, and following statement: "Miami-Dade County Product Control Approved", unless otherwise noted herein.

RENEWAL of this NOA shall be considered after a renewal application has been filed and there has been no change in the applicable building code negatively affecting the performance of this product.

TERMINATION of this NOA will occur after the expiration date or if there has been a revision or change in the materials, use, and/or manufacture of the product or process. Misuse of this NOA as an endorsement of any product, for sales, advertising or any other purposes shall automatically terminate this NOA. Failure to comply with any section of this NOA shall be cause for termination and removal of NOA.

ADVERTISEMENT: The NOA number preceded by the words Miami-Dade County, Florida, and followed by the expiration date may be displayed in advertising literature. If any portion of the NOA is displayed, then it shall be done in its entirety.

INSPECTION: A copy of this entire NOA shall be provided to the user by the manufacturer or its distributors and shall be available for inspection at the job site at the request of the Building Official. This NOA revises NOA # 19-1015.14 and consists of this page 1 and evidence pages E-1 and E-2, as well as approval document mentioned above.

The submitted documentation was reviewed by **Carlos M. Utrera, P.E.**



NOA No. 22-0912.01
Expiration Date: November 20, 2024
Approval Date: October 13, 2022
Page 1

NOTICE OF ACCEPTANCE: EVIDENCE SUBMITTED

1. Evidence submitted under NOA #18-0719.03

A. DRAWINGS

1. Drawing No. **60-022497-00D**, titled “PHHW Penthouse”, sheets 1 through 11 of 11, dated 12/04/2017, prepared by Air System Components, Inc. dba PennBarry, signed and sealed by Melissa M. Massar, P.E. on 08/08/2018.

B. TESTS “Submitted under NOA # 08-1003.05”

1. Test reports on 1) Uniform Static Air Pressure Test, Loading per FBC TAS 202-94
2) Large Missile Impact Test per FBC, TAS 201-94
3) Cyclic Wind Pressure Loading per FBC, TAS 203-94
along with marked-up drawings and installation diagram of Series/Model PHB6625D Penthouse, prepared by Architectural Testing, Inc., Test Report No. **73628.01-401-18**, dated 09/05/2007, signed and sealed by Joseph A. Reed, P.E.

C. CALCULATIONS “Submitted under NOA # 18-1025.03”

1. Wind load review prepared by Ruskin Company, dated 08/18/2018, signed and sealed by Melissa M. Massar, P.E.

D. QUALITY ASSURANCE

1. Miami-Dade Department of Regulatory and Economic Resources (RER)

E. MATERIAL CERTIFICATIONS

1. None.

F. STATEMENTS “Submitted under NOA # 18-1025.03”

1. Statement letter of code conformance to the 6th edition (2017) FBC issued by Ruskin Company, dated 08/18/2018, signed and sealed by Melissa M. Massar, P.E.
2. Private label agreement dated 08/30/2018.



Carlos M. Utrera, P.E.
Product Control Examiner
NOA No. 22-0912.01
Expiration Date: November 20, 2024
Approval Date: October 13, 2022

NOTICE OF ACCEPTANCE: EVIDENCE SUBMITTED

2. New evidence submitted

A. DRAWINGS

1. Drawing No. **60-022497-00D**, titled "PHHW Penthouse", sheets 1 through 11 of 11, dated 12/04/2017, prepared by Air System Components, Inc. dba PennBarry, signed and sealed by Jeffrey D. Smith, P.E. on 08/16/2022.

B. TESTS

1. None.

C. CALCULATIONS

1. None.

D. QUALITY ASSURANCE

1. Miami-Dade Department of Regulatory and Economic Resources (RER).

E. MATERIAL CERTIFICATIONS

1. None.

F. STATEMENTS

1. Statement letter of code conformance to the 7th edition (2020) of the FBC, issued by Air System Components, Inc. dba PennBarry, dated 08/16/2022, signed and sealed by Jeffrey D. Smith, P.E.
2. Statement letter of no financial interest, issued by Air System Components, Inc. dba PennBarry, dated 08/16/2022, signed and sealed by Jeffrey D. Smith, P.E.
3. Private label agreement dated 05/26/2022.



Carlos M. Utrera, P.E.
Product Control Examiner
NOA No. 22-0912.01
Expiration Date: November 20, 2024
Approval Date: October 13, 2022

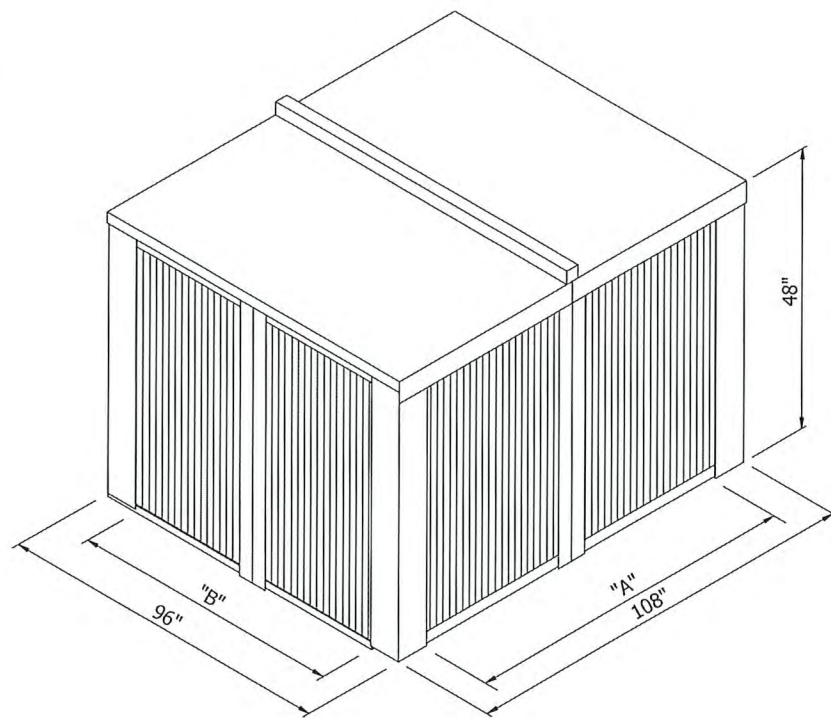

PENTHOUSE ISOMETRIC

FRAME
6063-T6 extruded aluminum with .095" nominal wall thickness.
BLADES
6063-T6 extruded aluminum with .080" nominal wall thickness.
ROOF
.080 thick formed aluminum panels
SILL
.125" thick formed aluminum
FINISH
Mill

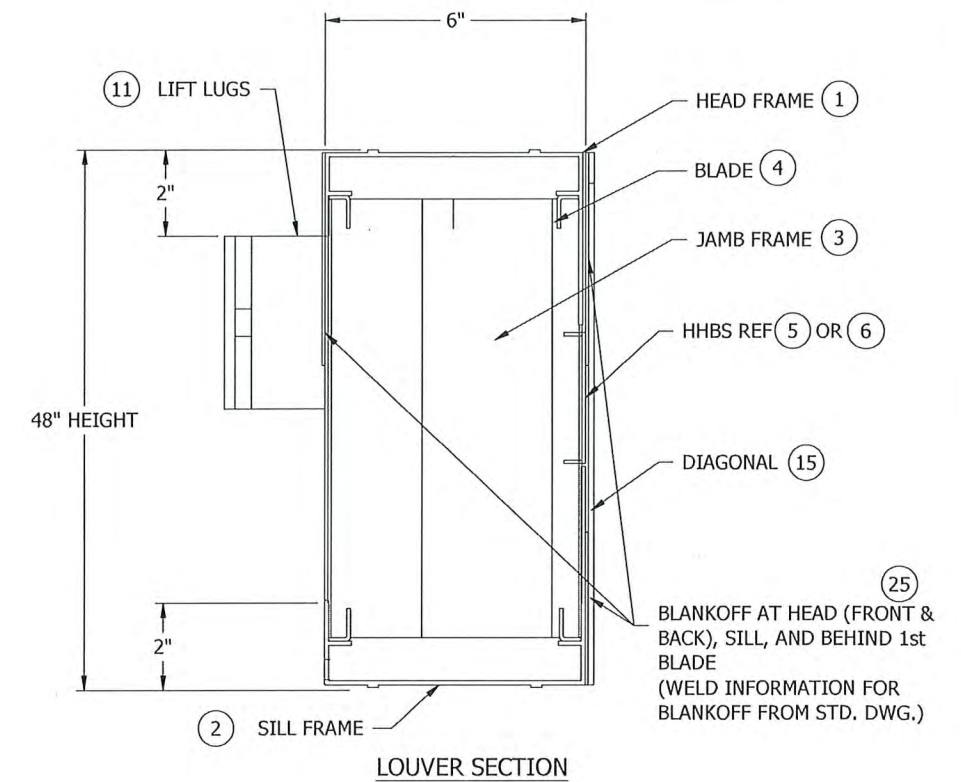

LOUVER SECTION

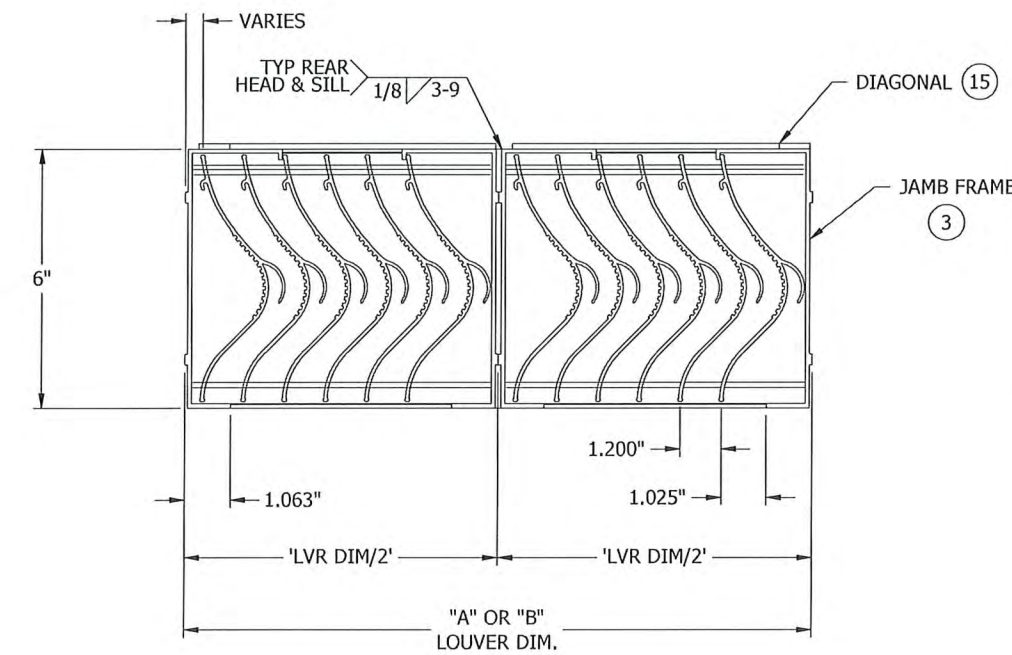

LOUVER PLAN VIEW

NOTE:
REF SHEET 6 FOR DESCRIPTION OF LINE ITEMS

NOTES:

- 1) THE PHHW HAS BEEN TESTED IN ACCORDANCE WITH FLORIDA PROTOCOLS TAS-201, 202 & 203 FOR LARGE MISSILE IMPACT, UNIFORM PRESSURE AND CYCLIC WIND PRESSURE.
- 2) THIS PENTHOUSE SYSTEM IS APPROVED FOR APPLICATIONS WITH DESIGN PRESSURES OF +/- 110 PSF OR LESS.
- 3) IT SHALL BE THE RESPONSIBILITY OF THE PERMIT HOLDER/BUILDING DESIGN ENGINEER OF RECORD TO VERIFY THE STRUCTURAL INTEGRITY OF THE ROOF CURB/STRUCTURE TO SUPPORT THE LOADS IMPOSED BY THIS PENTHOUSE SYSTEM.
- 4) 'A'+12" AND 'B'+12" ARE THE OUTSIDE DIMENSIONS OF THE PENTHOUSE SIDES. 'A' AND 'B' ARE THE INSIDE DIMENSIONS OF THE CURB.
- 5) THE MAXIMUM OUTSIDE DIMENSIONS OF THE PENTHOUSE ARE 96"x108"x48" TALL AS INDICATED ON THESE DRAWINGS. THE MINIMUM OUTSIDE DIMENSIONS OF THE PENTHOUSE ARE 24"x24"x12" TALL.
- 6) SEALING REQUIREMENTS AROUND THE PENTHOUSE SHALL COMPLY WITH THE PROVISIONS OF CHAPTER 15 OF THE FLORIDA BUILDING CODE.
- 7) ALL FASTENERS SHALL BE CORROSION RESISTANT.

FOR OFFICE USE ONLY

PRODUCT REVISED
as complying with the Florida Building Code
NOA-No. 22-0912.01
Expiration Date 11/20/2024
By *[Signature]*
Miami-Dade Product Control

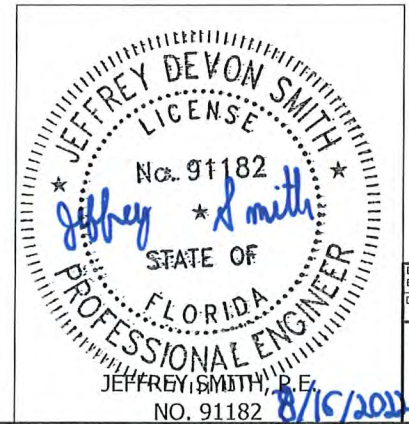

DRAWN BY: CJD	CHECKED BY: SDL	APPROVED BY: MMM	DATE: 12/4/17	DATE: 12/4/17	DATE: 12/4/17	DATE: 12/4/17	REV'D ENGINEER OF RECORD, TITLE BLOCK	NS	XXX	XXX	12040	08/12/22
SHEET 1 OF 11							REVISION DESCRIPTION	DRAWN BY:	CHK'D BY:	APP'D BY:	ECN	DATE
							605 Shiloh RD Plano, TX 75074	FLOTT SCALE	NONE	ECN	12040	
							PENNBARRY	TITLE	PHHW PENNHOUSE SPECS, NOTES AND DETAILS		DWG. NO. 60-022497-00D	

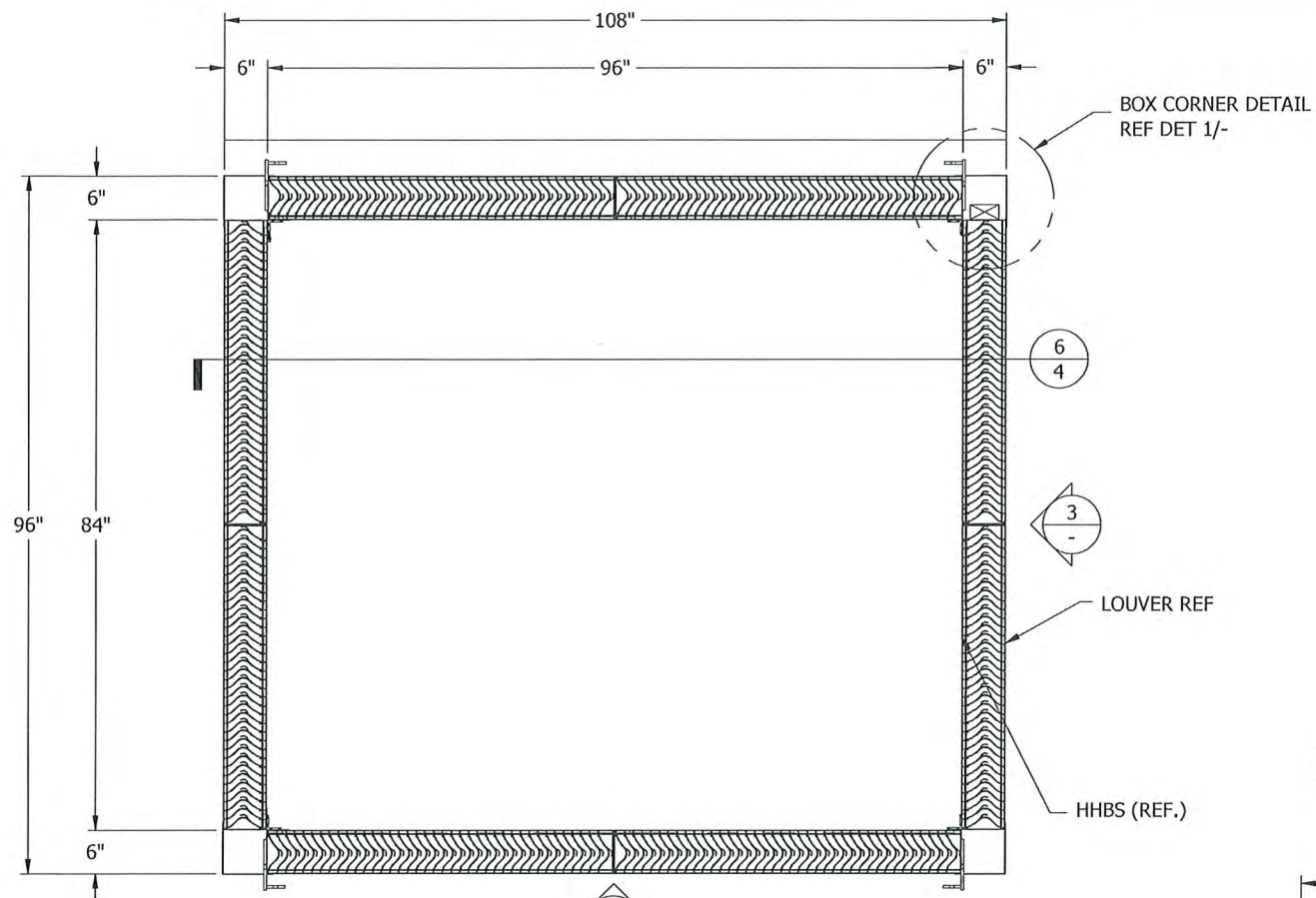

ASSEMBLY "A"
 N.T.S.
 HEIGHT = 48"

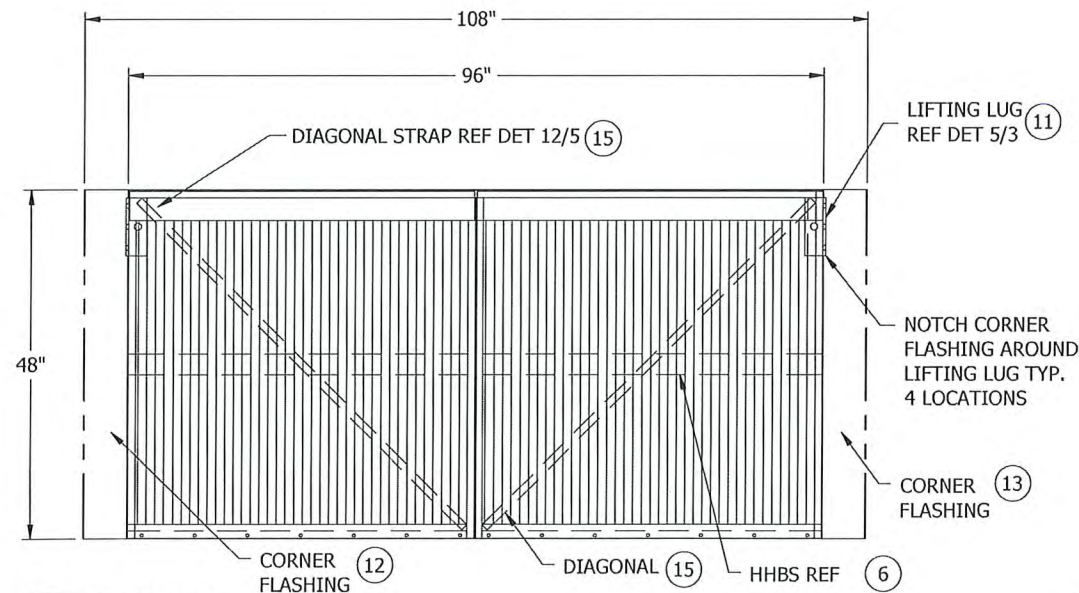

2 ELEVATION
 N.T.S.

NOTE:
 REF SHEET 6 FOR DESCRIPTION OF LINE ITEMS

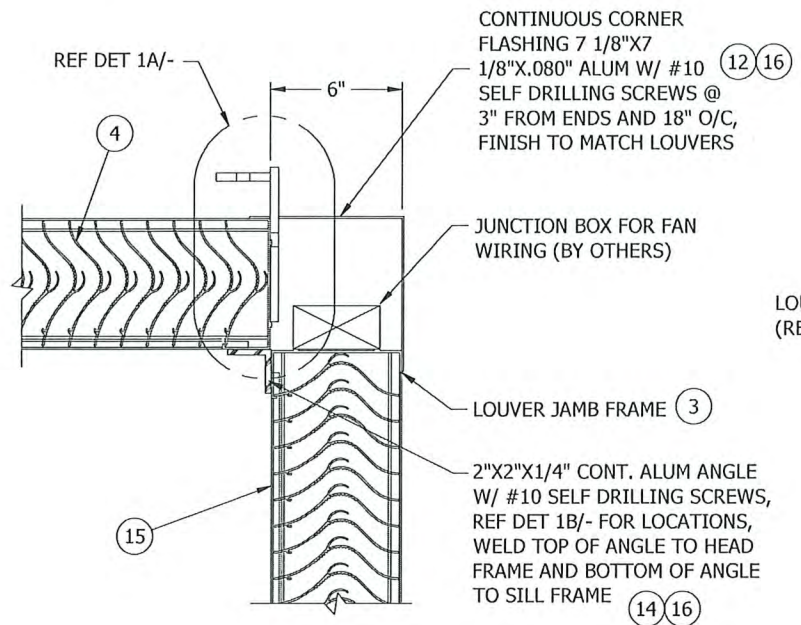

1 BOX CORNER DETAIL
 N.T.S.

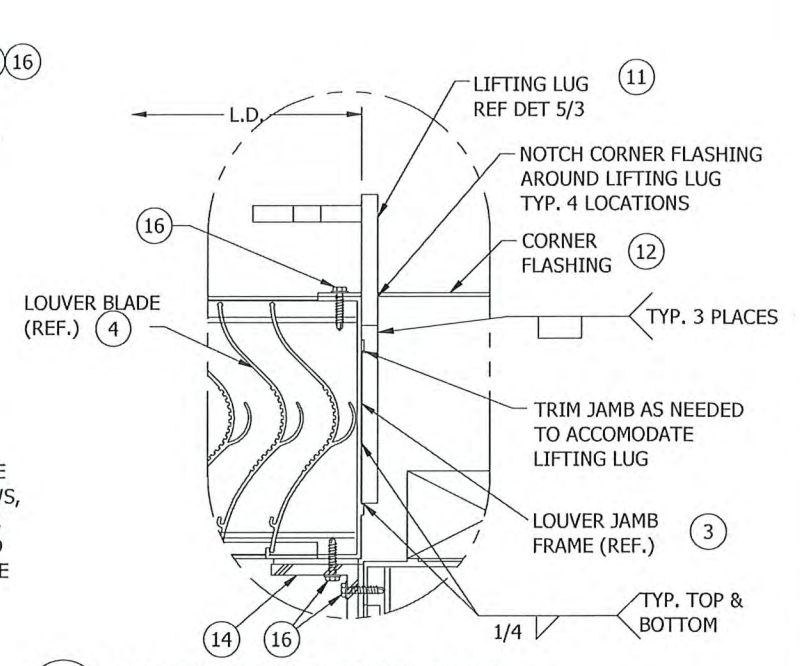

1A LOUVER/CORNER FLASHING DETAIL
 N.T.S.

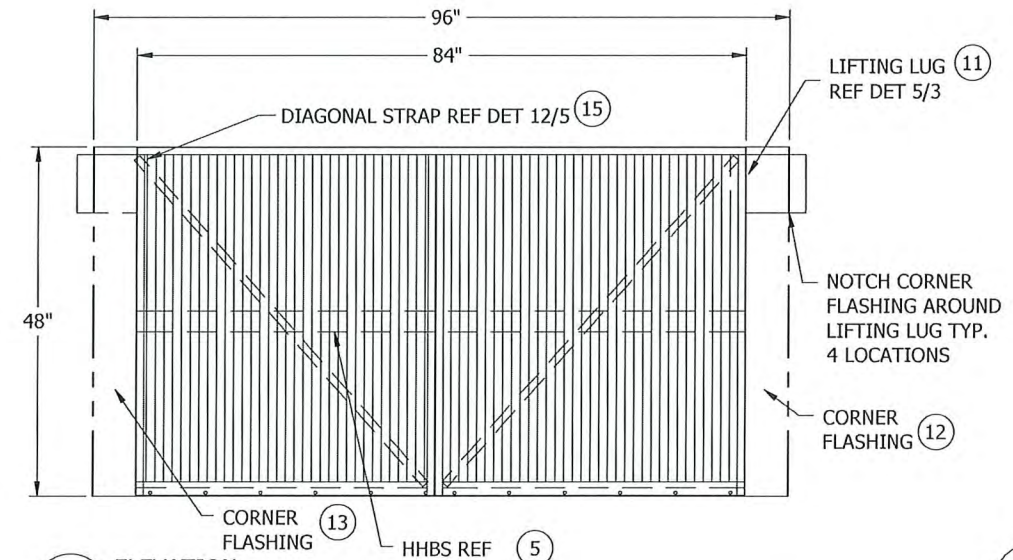

3 ELEVATION
 N.T.S.

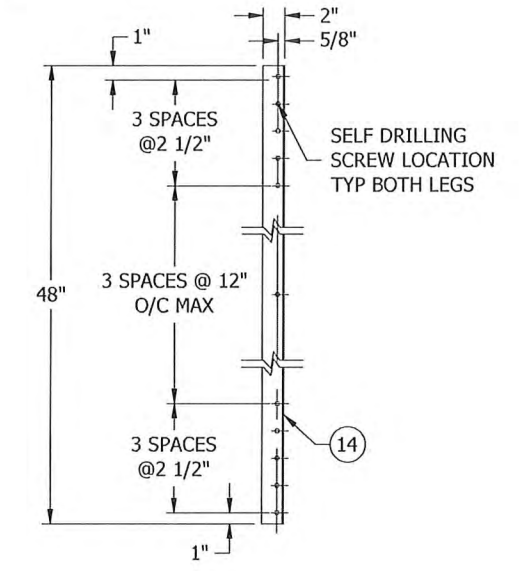

1B ITEM 14 - LOUVER CORNER ANGLE
 N.T.S.

FOR OFFICE USE ONLY

PRODUCT REVISED
 as complying with the Florida Building Code
 NOA-No. 22-0912.01
 Expiration Date 11/20/2024
 By *[Signature]*
 Miami-Dade Product Control

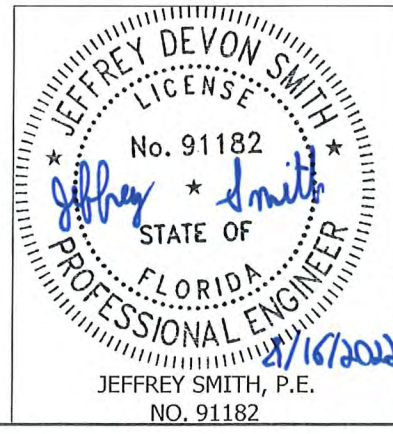

DRAWN BY: CJD	CHK. BY: SDL	APP'D. BY: MMM	APP'D. BY:
DATE: 12/4/17	DATE: 12/4/17	DATE: 12/4/17	DATE:

SHEET 2 OF 11

(A)	REV'D ENGINEER OF RECORD, TITLE BLOCK	NS	XXX	XXX	12040	08/12/22
CHANGE LETTER	REVISION DESCRIPTION	DRAWN BY:	CHK'D. BY:	APP'D. BY:	ECH	DATE
	PENN BARRY 605 Shiloh RD Plano, TX 75074	PLOT SCALE		ECN	12040	
	PHHW PENNHOUSE DETAILS	DWG. NO.		60-022497-00D		

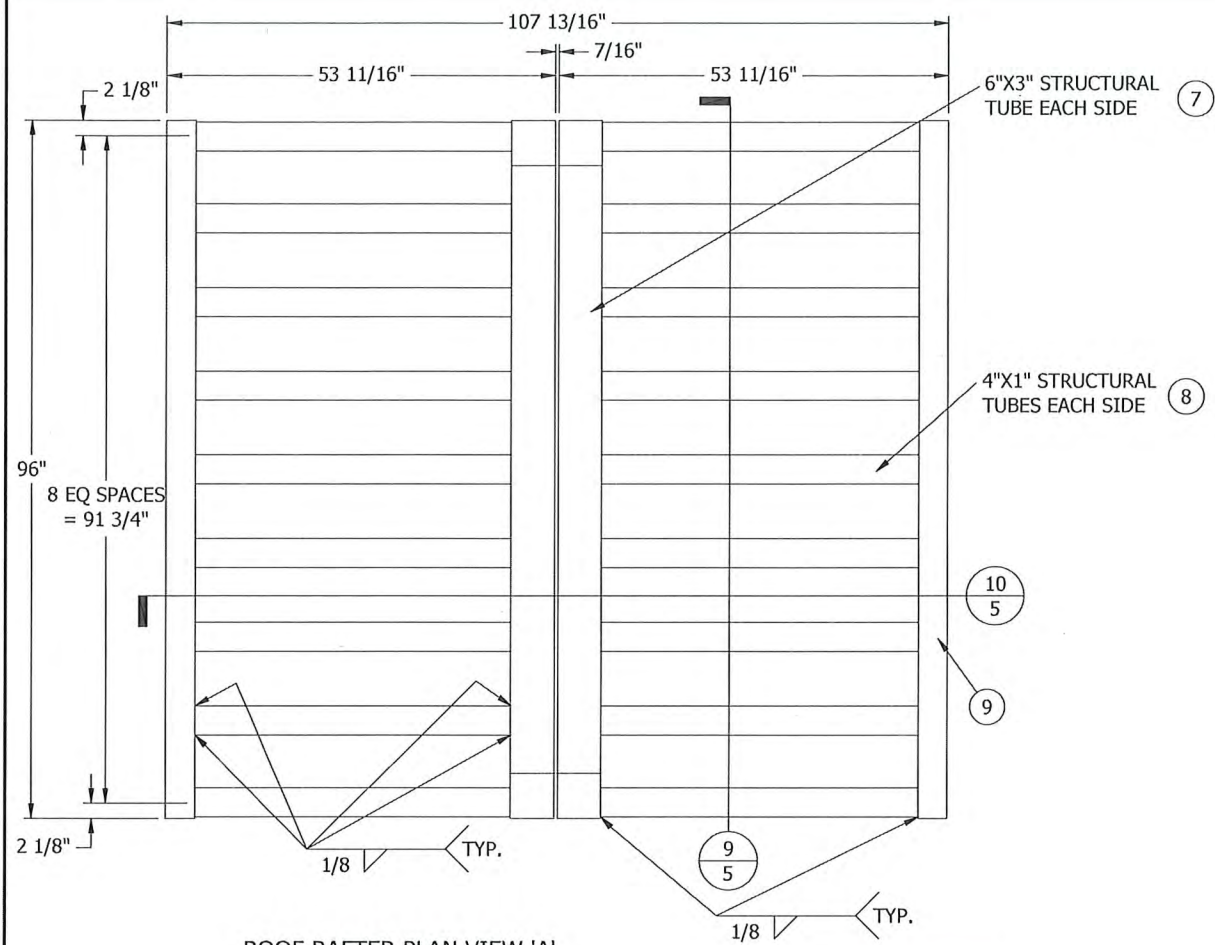

ROOF RAFTER PLAN VIEW 'A'
NTS

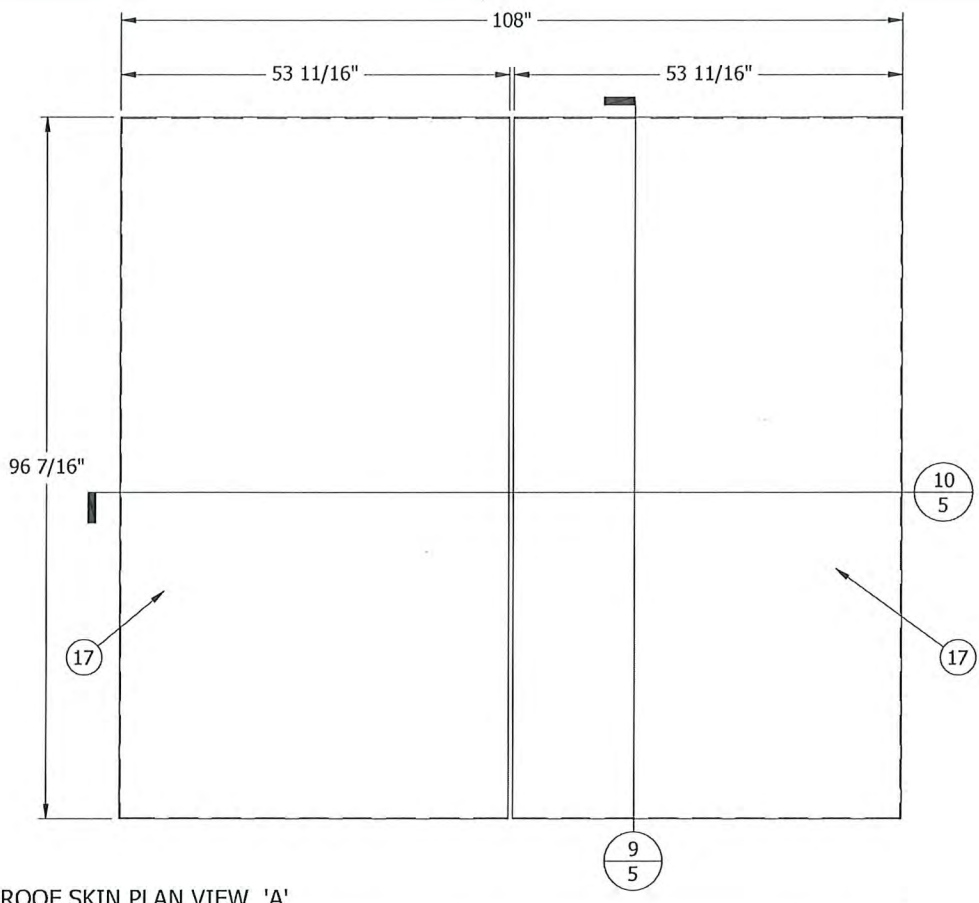

ROOF SKIN PLAN VIEW 'A'
NTS

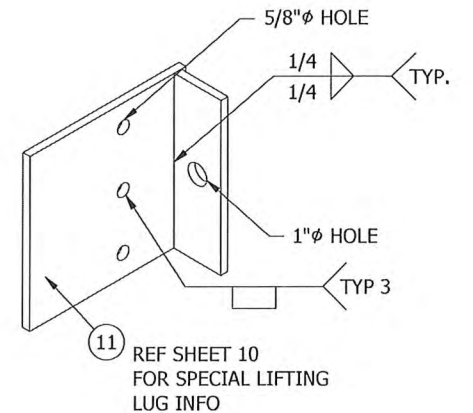

5 SPECIAL LIFTING LUG
2 NTS
MAT'L: .375\"/>

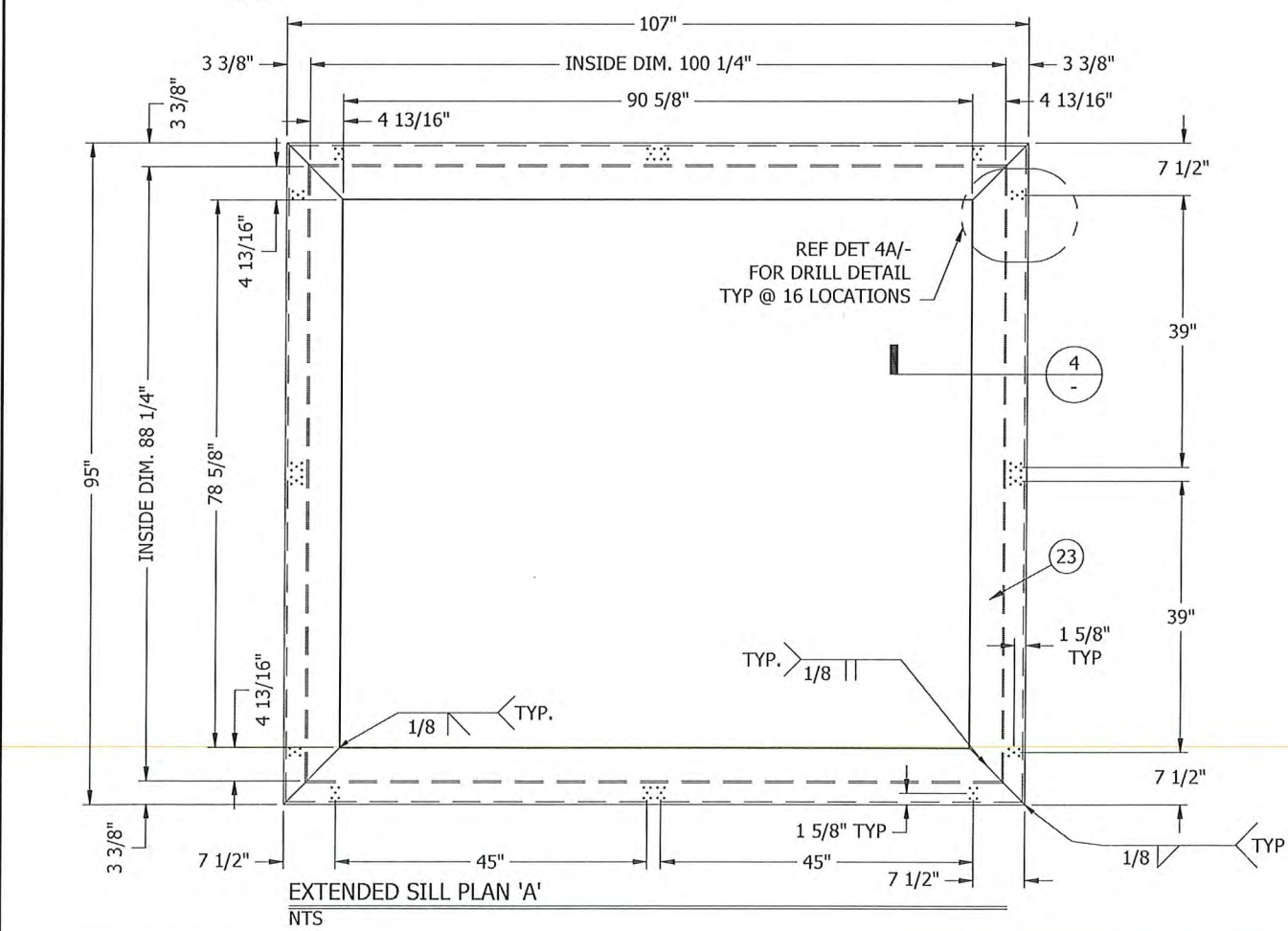

EXTENDED SILL PLAN 'A'
NTS

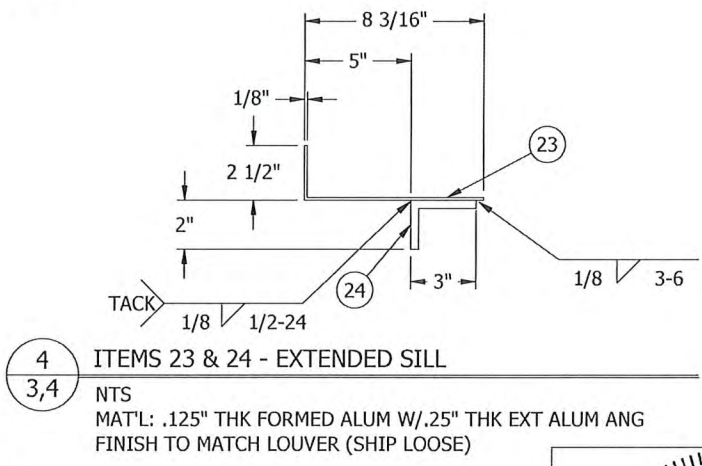

4 ITEMS 23 & 24 - EXTENDED SILL
3,4 NTS
MAT'L: .125\"/>

NOTE:
REF SHEET 6 FOR DESCRIPTION OF LINE ITEMS

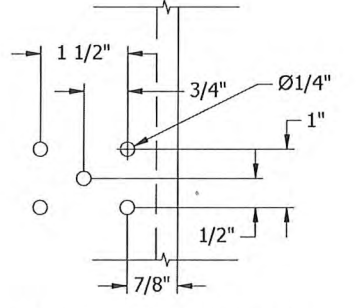

4A EXTENDED SILL DRILL DETAIL
3,4 NTS

FOR OFFICE USE ONLY

PRODUCT REVISED
as complying with the Florida Building Code
NOA-No. 22-0912.01
Expiration Date 11/20/2024

By *[Signature]*
Miami-Dade Product Control

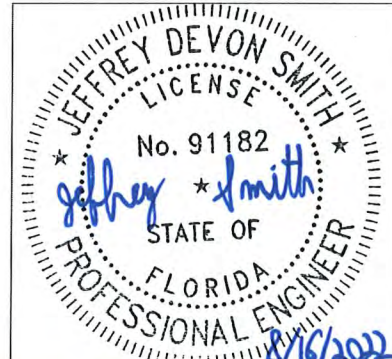

JEFFREY SMITH, P.E.
NO. 91182

DRAWN BY: CJD	CHK. BY: SDL	APP'D. BY: MMM	APP'D. BY:
DATE: 12/4/17	DATE: 12/4/17	DATE: 12/4/17	DATE:

SHEET 3 OF 11

(A)	REV'D ENGINEER OF RECORD, TITLE BLOCK	NS	XXX	XXX	12040	08/12/22
CHANGE LETTER	REVISION DESCRIPTION	DRAWN BY:	CHK. D. BY:	APP'D. BY:	ECN	DATE
PENN BARRY 605 Shiloh RD Plano, TX 75074		PLOT SCALE NONE		ECN 12040		
TITLE PHHW PENNHOUSE DETAILS				DIV. NO. 60-022497-00D		

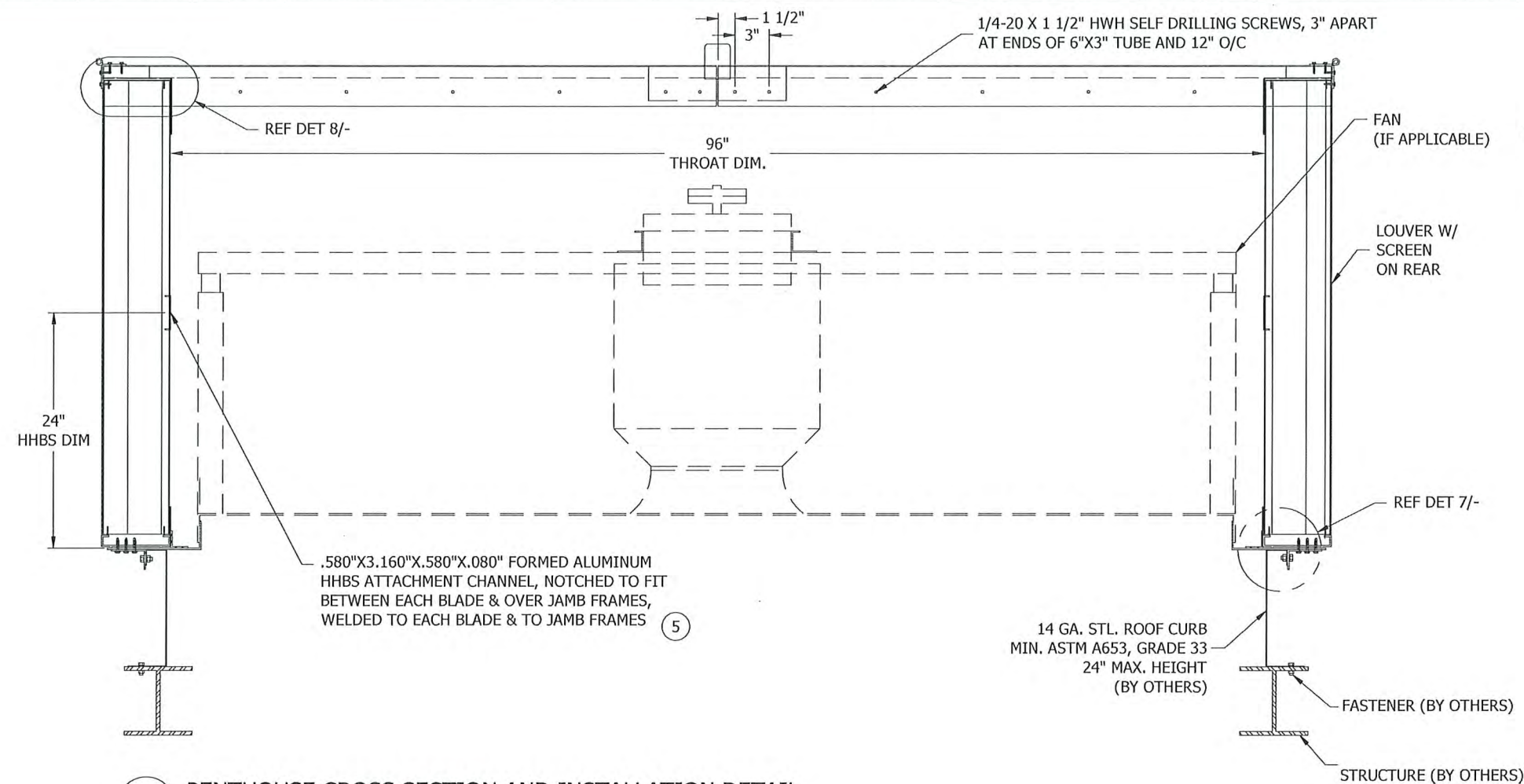

6 PENTHOUSE CROSS SECTION AND INSTALLATION DETAIL
2 NTS

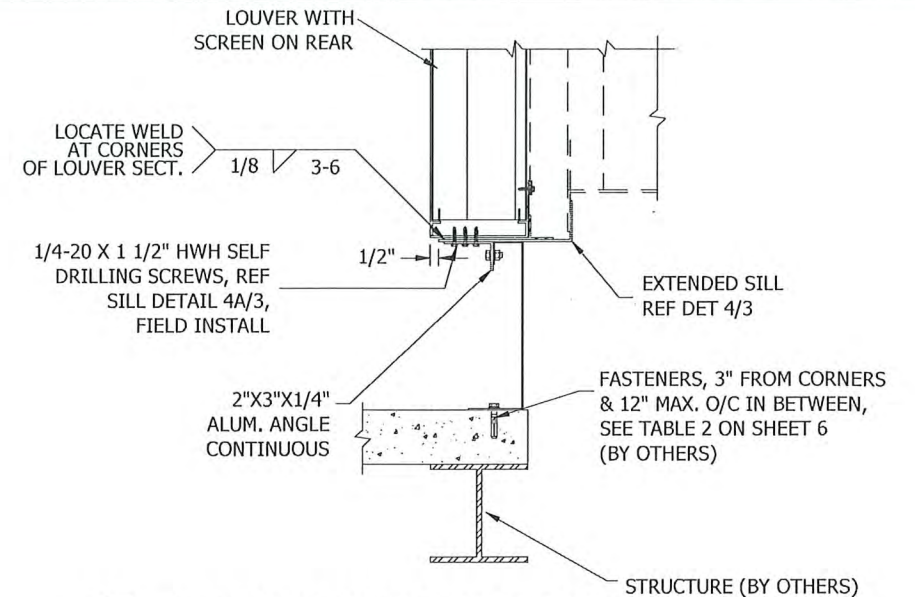

6A PENTHOUSE INSTALL (OPTIONAL)
- NTS (FOR DETAILS NOT NOTED REF DET 6/-)

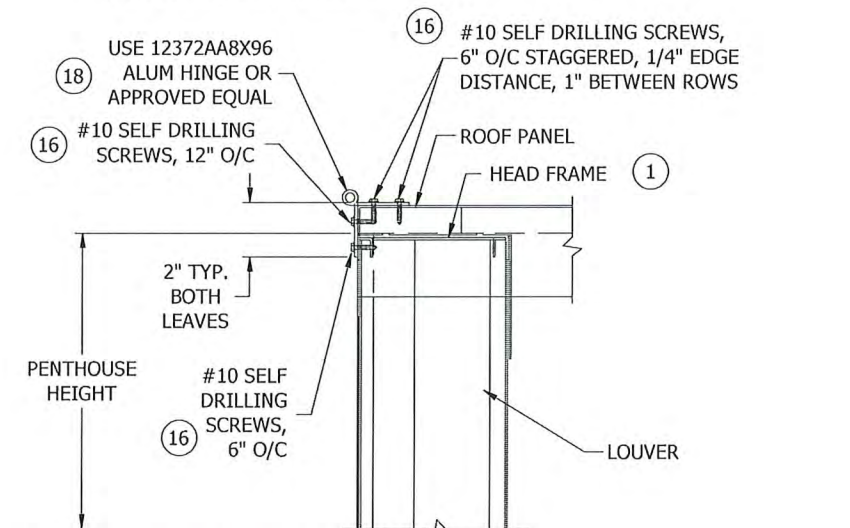

8 ROOF FASTENING DETAIL
- NTS

NOTE: REF SHEET 6 FOR DESCRIPTION OF LINE ITEMS

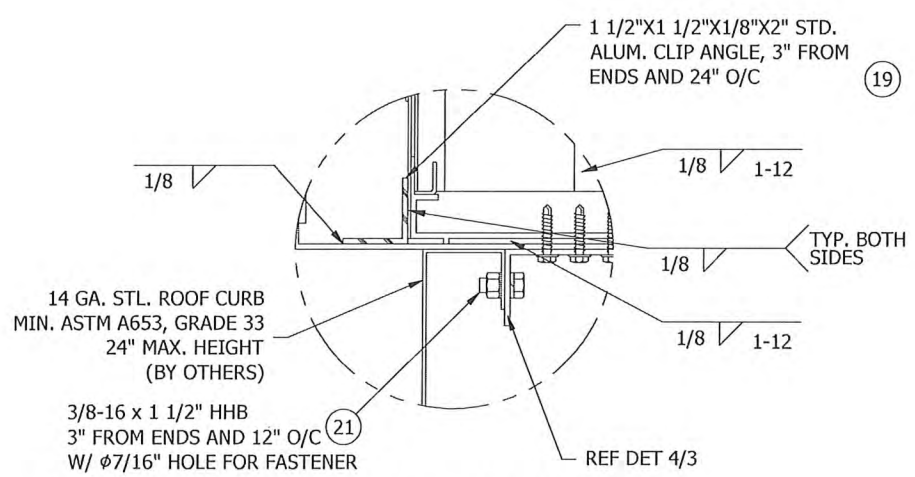

7 PENTHOUSE/CURB CONNECTION DETAIL
- NTS

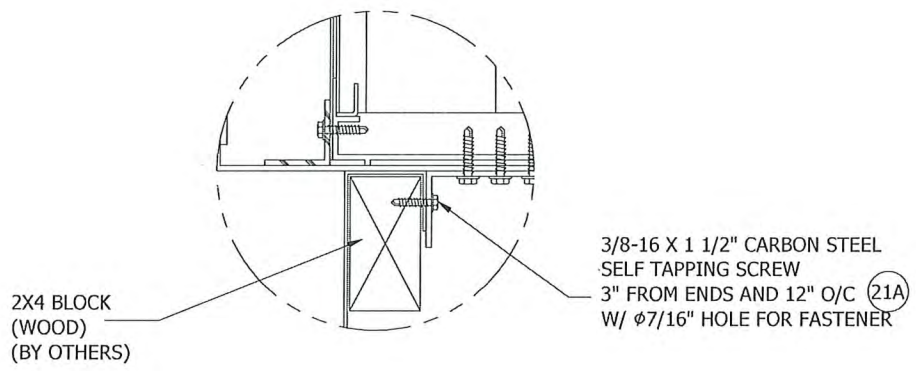

7A PENTHOUSE/INSULATED CURB CONNECTION DETAIL
- NTS

FOR OFFICE USE ONLY

PRODUCT REVISED
as complying with the Florida Building Code
NOA-No. 22-0912.01
Expiration Date 11/20/2024

By *[Signature]*
Miami-Dade Product Control

JEFFREY DEVON SMITH
LICENSE No. 91182
STATE OF FLORIDA
PROFESSIONAL ENGINEER
[Signature]
JEFFREY SMITH, P.E.
NO. 91182

ENGR. BY: CJD	CHK. BY: SDL	APP'D. BY: MMM	APP'D. BY:
DATE: 12/4/17	DATE: 12/4/17	DATE: 12/4/17	DATE:

SHEET 4 OF 11

(A) REV'D ENGINEER OF RECORD, TITLE BLOCK	NS	XXX	XXX	12040	08/12/22
CHANGE LETTER	REVISION DESCRIPTION	DRAW. BY:	CHK. BY:	APP'D. BY:	ECH DATE
605 Shiloh RD Plano, TX 75074		PLOT SCALE NONE		ECN 12040	
PHHW PENNHOUSE DETAILS				DWG. NO. 60-022497-00D	

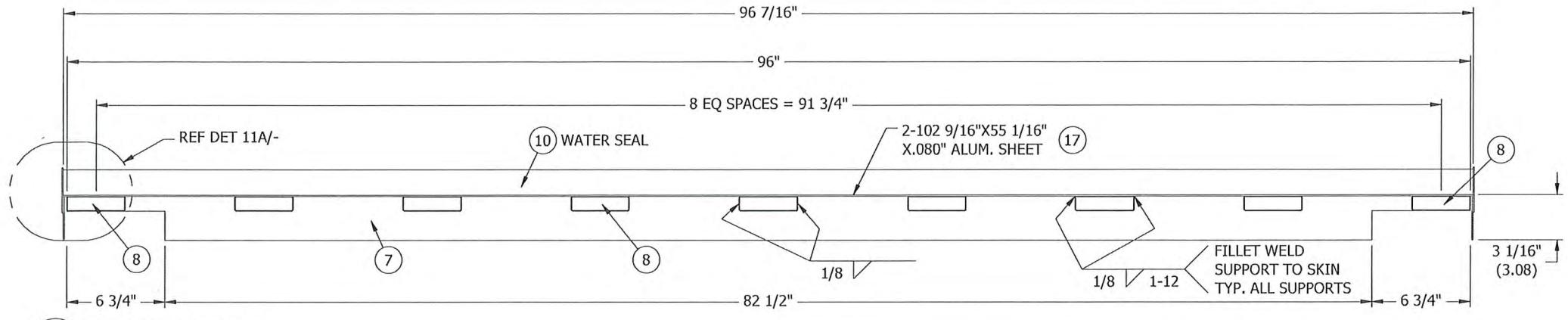

9 ROOF SECTION ASSEMBLY
3 NTS

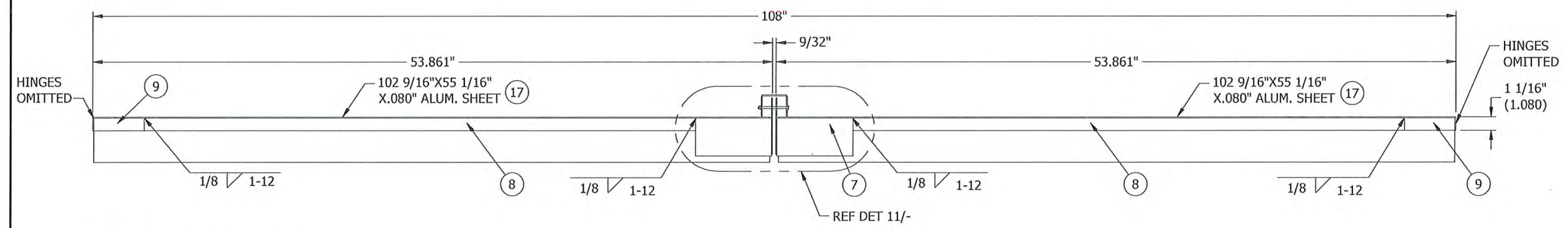

10 ROOF SECTION ASSEMBLY
3 NTS

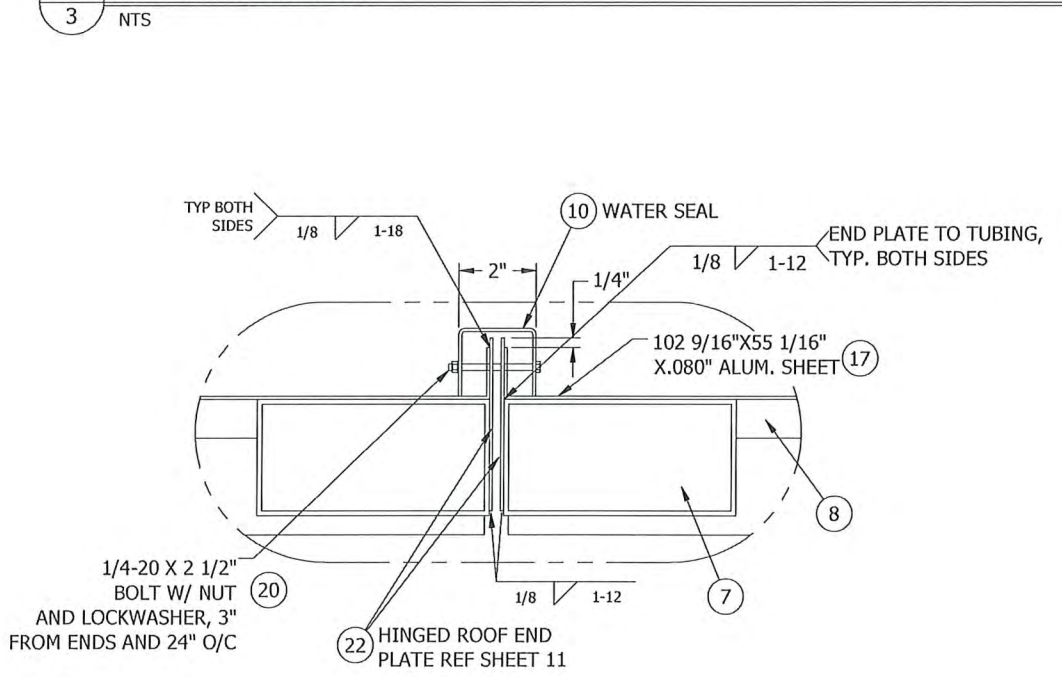

11 ROOF SECTION
NTS

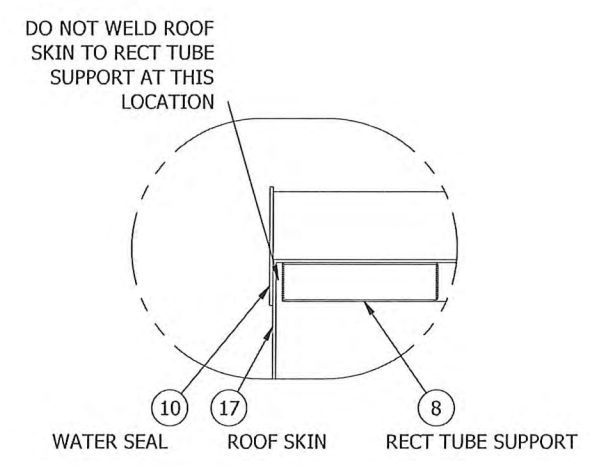

11A ROOF SECTION
NTS

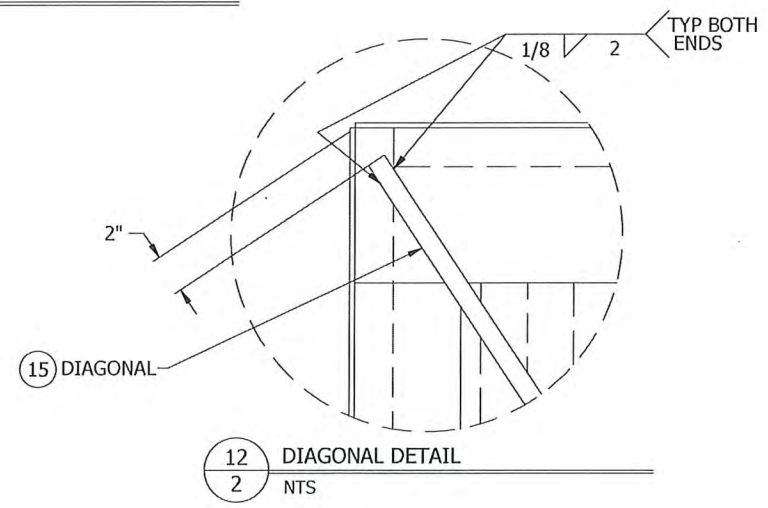

12 DIAGONAL DETAIL
2 NTS

FOR OFFICE USE ONLY

PRODUCT REVISED
as complying with the Florida Building Code
NOA-No. 22-0912.01
Expiration Date 11/20/2024
By *R. Smith*
Miami-Dade Product Control

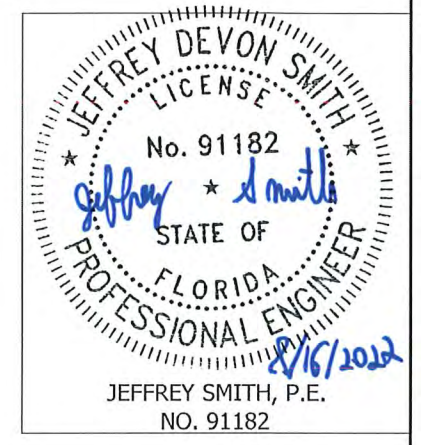

NOTE:
REF SHEET 6 FOR DESCRIPTION OF LINE ITEMS

REV'D ENGINEER OF RECORD, TITLE BLOCK	NS	XXX	XXX	12040	08/12/22
CHANGE LETTER	REVISION DESCRIPTION	D/W/L BY:	CHK'D. BY:	APP'D. BY:	ECN DATE
DRAWN BY: CJD	CHK. BY: SDL	APP'D. BY: MMM	DATE: 12/4/17	DATE: 12/4/17	DATE: 12/4/17
SHEET 5 OF 11			605 Shiloh RD Plano, TX 75074		FLOT SCALE NONE
PHHW PENNHOUSE DETAILS			ECN 12040		DWG. NO. 60-022497-00D

LINE ITEM	SHEET NUMBER	MATERIAL	DESCRIPTION	PENNBARRY NUMBER
1	7	6063-T6 ALUM	LOUVER HEAD FRAME	70-021995-00B
2	7	6063-T6 ALUM	LOUVER SILL FRAME	70-022627-00B
3	7	6063-T6 ALUM	LOUVER JAMB FRAME	70-022227-00B
4	7	6063-T6 ALUM	LOUVER BLADE	70-020748-00B
5	8	6063-T5 ALUM	.580"X3.160"X.580"X.080"X84" HHBS	RSM7001
6	8	6063-T5 ALUM	.580"X3.160"X.580"X.080"X96" HHBS	RSM7001
7	8	6063-T5 1/8" ALUM	6"X3" RECT. TUBE ROOF SUPPORT	-
8	8	6063-T6 1/8" ALUM	4"X1" RECT. TUBE SUPPORT (SHORT)	-
9	9	6063-T6 1/8" ALUM	4"X1" RECT. TUBE SUPPORT (LONG)	-
10	9	5005-H34 1/8" ALUM	WATER SEAL	-
11	9	3003-H14 3/8" ALUM	SPECIAL LIFTING LUG	-
12	10	5005-H34 .080" ALUM	LEFT HAND CORNER FLASHING	-
13	10	5005-H34 .080" ALUM	RIGHT HAND CORNER FLASHING	-
14	2	6063-T6 ALUM	2"X2"X1/4"X48" ANGLE	-
15	-	6063-T5 ALUM	DIAGONAL 1"X1/8" THK. BAR	-
16	-	CARBON STEEL, ZC	#10-16 X 1" SELF DRILLING SCREW	-
17	10	5005-H34 .080" ALUM	PENTHOUSE ROOF SKIN	-
18	11	5052 ALUM	12372AA8X96 HINGE-1/8" THK., 3/8" PIN, 2" KNUCKLE	-
19	10	5005-H34 ALUM	1 1/2"X1 1/2"X1/8"X2" CLIP ANGLE	85-020366-00B
20	-	CARBON STEEL, ZC	1/4-20 X 2 1/2" HHB W/ LOCKWASHER & HEX NUT	-
21	-	CARBON STEEL, ZC	3/8-16 X 1 1/2" HHB W/ WASHER, LOCKWASHER & HEX NUT	-
21A	-	CARBON STEEL, ZC	3/8-16 X 1 1/2" CARBON STEEL SELF TAPPING SCREW	-
22	11	5005-H34 ALUM	4 7/16"X95 7/8"X.080" HINGED DOOR END PLATE	-
23	3	5005-H34 ALUM	EXTENDED SILL .125" THK. FORMED	-
24	3	6063-T6 ALUM	EXTENDED SILL 2"X3"X1/4" ANGLE	-
25	-	-	BLANKOFF X" X Y" ALUM. SHEET	-

CURB SUBSTRATE FASTENER TABLE 2 (BY OTHERS)

SUBSTRATE TYPE	MIN. SUBSTRATE REQUIREMENTS	FASTENER TYPE	MIN. EMBEDMENT	MIN. EDGE DISTANCE
WOOD	0.42 SPECIFIC GRAVITY	3/8" DIA. LAG SCREW	3"	1 1/2"
STEEL	12 GA, 45 KSI TENSILE STRENGTH, 33 KSI YIELD STRENGTH	1/4" DIA. SELF TAPPING SCREW	3 THREADS BEYOND SUB.	3/8"
CONCRETE	2500 PSI COMP. STRENGTH	3/8" DIA. HILTI KWIK BOLT 3, CARBON STEEL	2 1/2"	2 1/2"

FOR OFFICE USE ONLY

PRODUCT REVISED
as complying with the Florida Building Code
NOA-No. 22-0912.01
Expiration Date 11/20/2024
By [Signature]
Miami-Dade Product Control

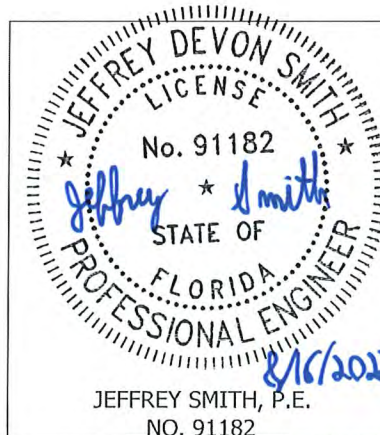

DRAWN BY: CJD	CHECKED BY: SDL	APPROVED BY: MMM	DATE: 12/4/17
DATE: 12/4/17	DATE: 12/4/17	DATE: 12/4/17	DATE:

SHEET 6 OF 11

(A)	REV'D ENGINEER OF RECORD, TITLE BLOCK	NS	XXX	XXX	12040	08/12/22
CHANGE LETTER	REVISION DESCRIPTION	DRAWN BY:	CHECKED BY:	APPROVED BY:	ECN	DATE
	B 605 Shiloh RD Plano, TX 75074	PLOT SCALE NONE		ECN	12040	
TITLE PHHW PENNHOUSE DETAILS					DWG. NO. 60-022497-00D	

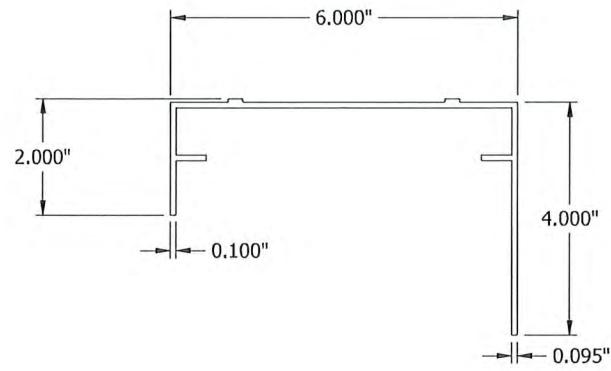

ITEM 1 - LOUVER HEAD FRAME

NTS

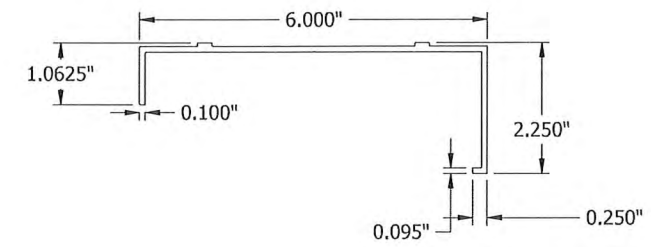

ITEM 3 - LOUVER JAMB FRAME

NTS

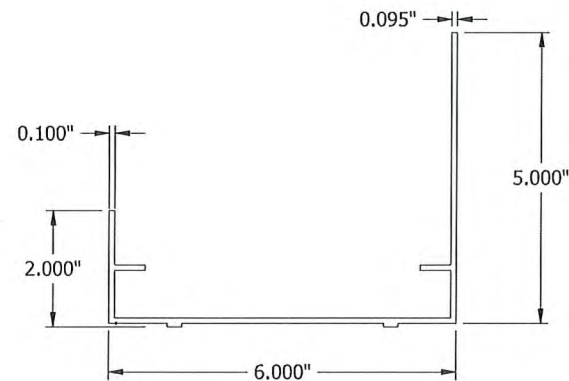

ITEM 2 - LOUVER SILL FRAME

NTS

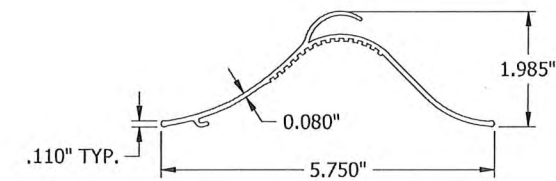

ITEM 4 - LOUVER BLADE

NTS

NOTES:
1. REF. SHEET 6 FOR MATERIAL.

FOR OFFICE USE ONLY

PRODUCT REVISED
as complying with the Florida
Building Code
NOA-No. 22-0912.01
Expiration Date 11/20/2024
By [Signature]
Miami-Dade Product Control

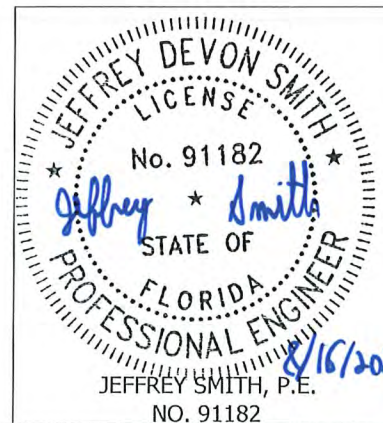

DRAWN BY: CJD	CHK. BY: SDL	APP'D. BY: MMM	APP'D. BY:
DATE: 12/4/17	DATE: 12/4/17	DATE: 12/4/17	DATE:

SHEET 7 OF 11

(A)	REV'D ENGINEER OF RECORD, TITLE BLOCK	NS	XXX	XXX	12040	08/12/22
CHANGE LETTER	REVISION DESCRIPTION	DRAWN BY:	CHK'D. BY:	APP'D. BY:	ECN	DATE
	PENN BARRY 605 Shiloh RD Plano, TX 75074	PLOT SCALE NONE		ECN	12040	
TITLE PHHW PENNHOUSE DETAILS		DWG. NO. 60-022497-00D				

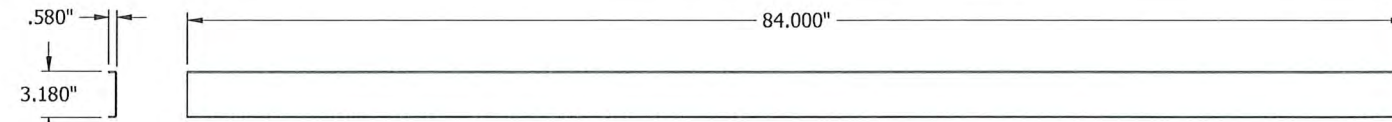

ITEM 5 - .580"X3.160"X.580"X.080"X84" HHBS

NTS

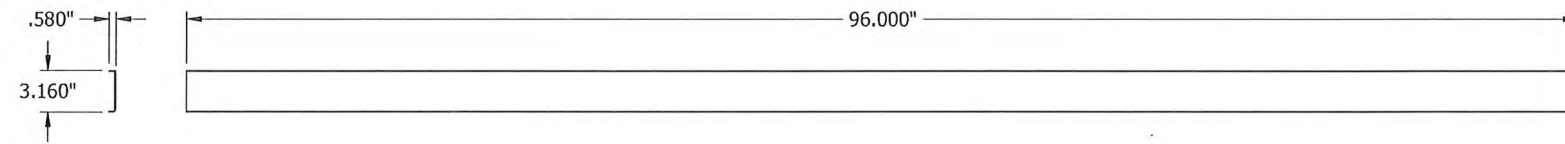

ITEM 6 - .580"X3.160"X.580"X.080"X96" HHBS

NTS

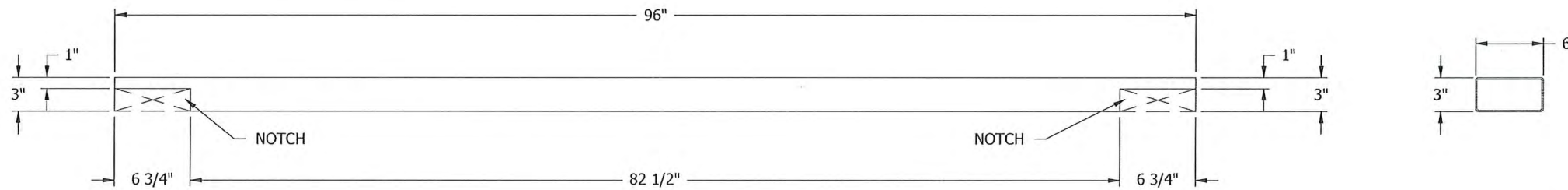

ITEM 7 - 6"X3" ROOF SUPPORT

NTS

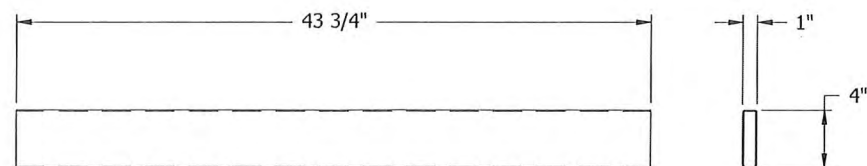

ITEM 8 - 4"X1" SUPPORT (SHORT)

NTS

NOTES:
1. REF. SHEET 6 FOR MATERIAL.

FOR OFFICE USE ONLY

PRODUCT REVISED
as complying with the Florida
Building Code
NOA-No. 22-0912.01
Expiration Date 11/20/2024
By *[Signature]*
Miami-Dade Product Control

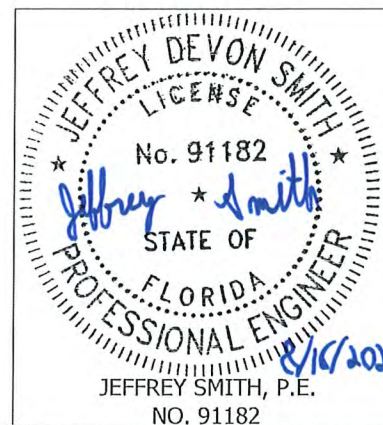

DRAWN BY: CJD	CHECKED BY: SDL	APPROVED BY: MMM	APPROVED BY:
DATE: 12/4/17	DATE: 12/4/17	DATE: 12/4/17	DATE:

SHEET 8 OF 11

(A)	REV'D ENGINEER OF RECORD, TITLE BLOCK	NS	XXX	XXX	12040	08/12/22
CHANGE LETTER	REVISION DESCRIPTION	DRAWN BY:	CHECKED BY:	APPROVED BY:	ECN	DATE
	605 Shiloh RD Plano, TX 75074	PLOT SCALE		ECN	12040	
		NONE				
	PHHW PENNHOUSE DETAILS	DWG. NO.		60-022497-00D		

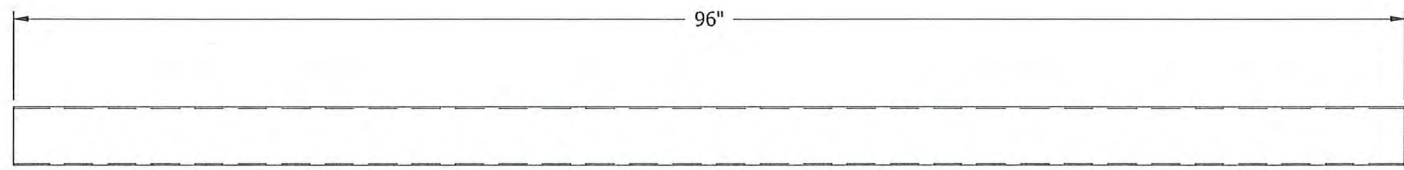

ITEM 9 - 4\"/>

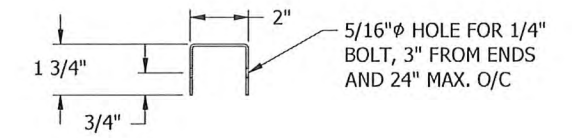
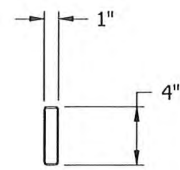

ITEM 10 - WATER SEAL

NTS
LENGTH: 96 7/16\"/>

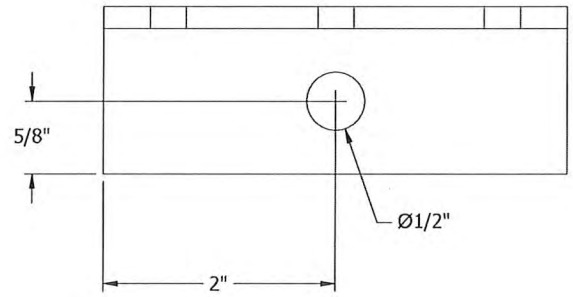
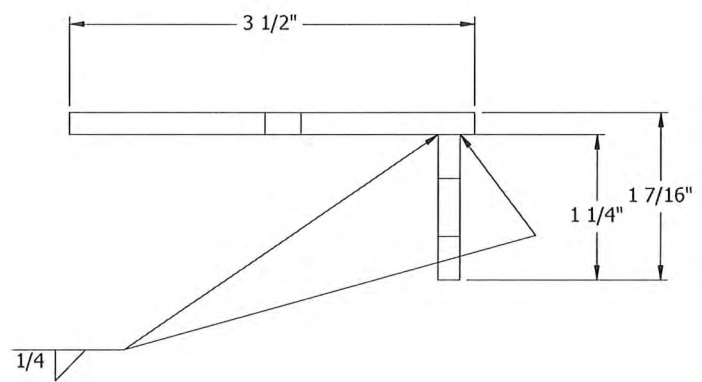

ITEM 11 - SPECIAL LIFTING LUG

NTS

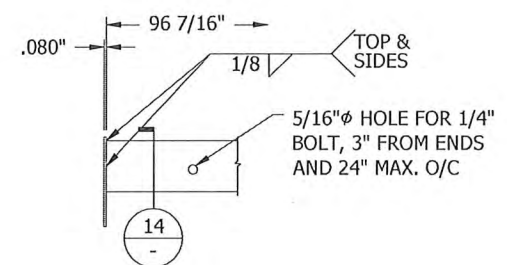
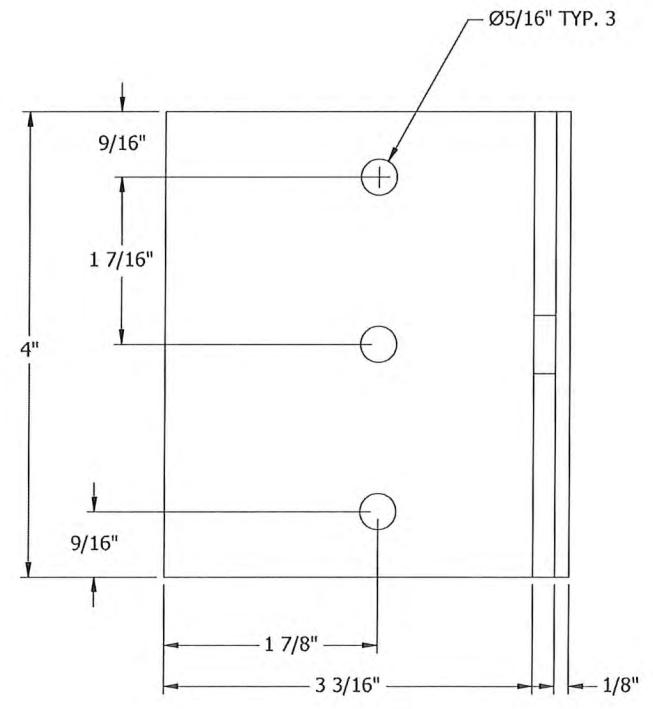

13 WATER SEAL AT END

NTS

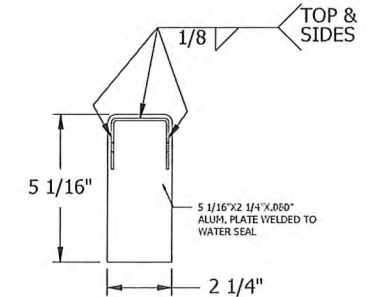

14 WATER SEAL AT END DETAIL

NTS

NOTES:
1. REF SHEET 6 FOR MATERIAL.

FOR OFFICE USE ONLY

PRODUCT REVISED
as complying with the Florida Building Code
NOA-No. 22-0912.01
Expiration Date 11/20/2024
By *[Signature]*
Miami-Dade Product Control

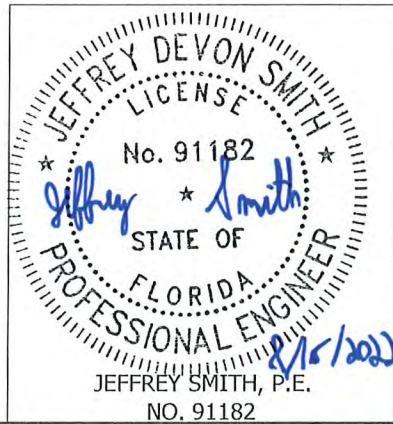

DRAWN BY: CJD	CHECKED BY: SDL	APPROVED BY: MMM	APPROVED BY:
DATE: 12/4/17	DATE: 12/4/17	DATE: 12/4/17	DATE:

SHEET 9 OF 11

(A)	REVD ENGINEER OF RECORD, TITLE BLOCK	NS	XXX	XXX	12040	08/12/22
CHANGE LETTER	REVISION DESCRIPTION	DRAWN BY:	CHK'D BY:	APP'VD BY:	ECN	DATE
	B 605 Shiloh RD Plano, TX 75074	FLOT SCALE	ECN 12040			
TITLE	PHHW PENNHOUSE DETAILS	DWG. NO.	60-022497-00D			

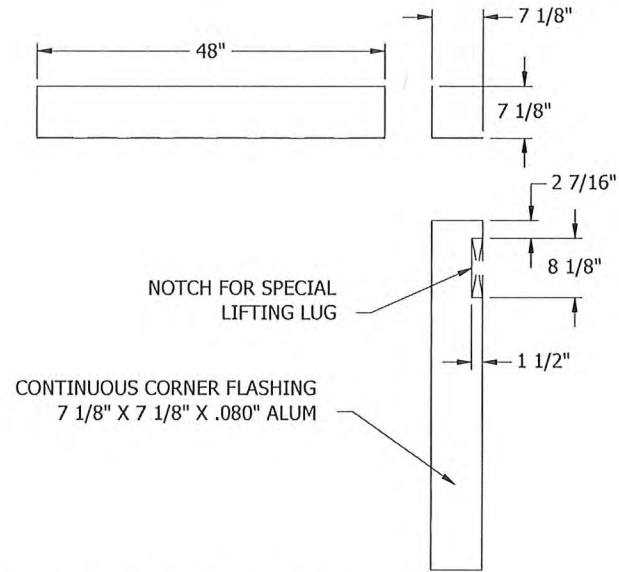

ITEM 12 - LEFT HAND CORNER FLASHING
NTS

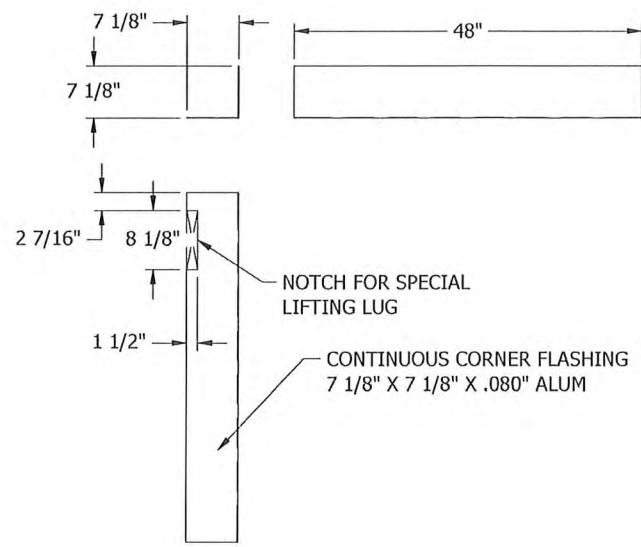

ITEM 13 - RIGHT HAND CORNER FLASHING
NTS

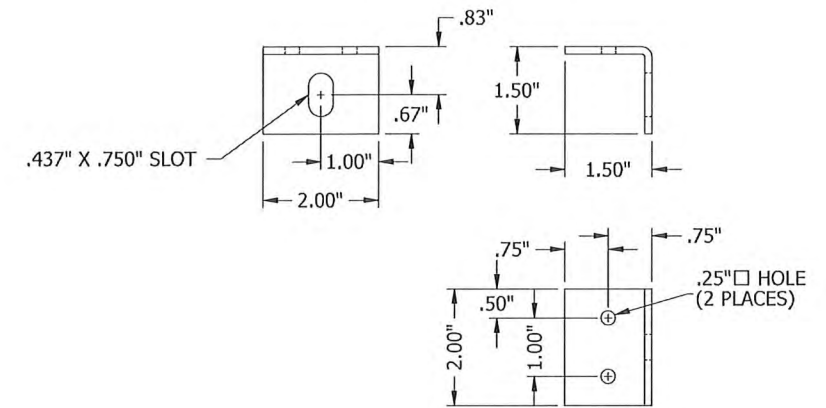

ITEM 19 - 1 1/2\"/>

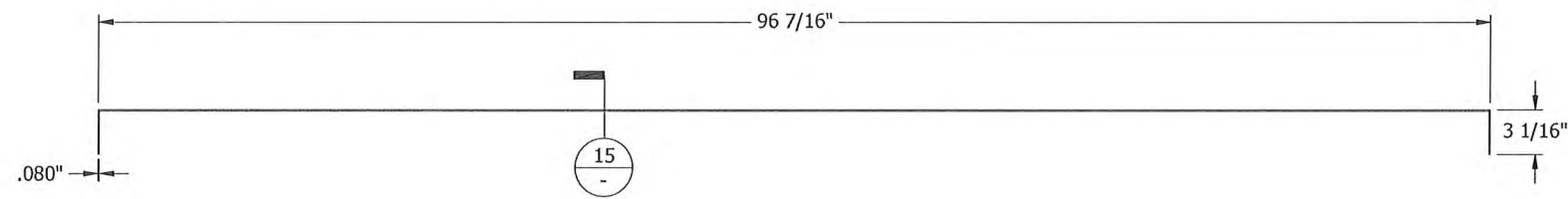

ITEM 17 - PENTHOUSE ROOF SKIN
NTS

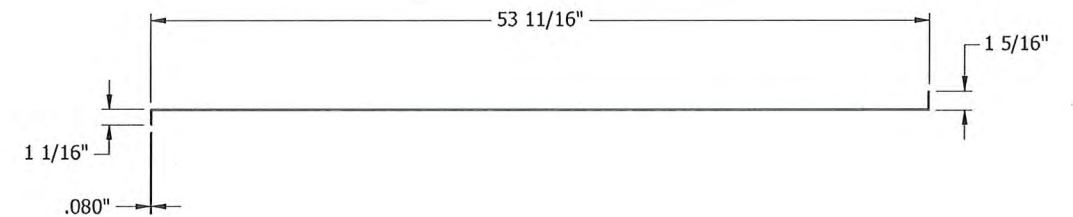

15 PENTHOUSE ROOF SKIN SECTION
NTS

NOTES:
1. REF SHEET 6 FOR MATERIAL.

FOR OFFICE USE ONLY

PRODUCT REVISED
as complying with the Florida
Building Code
NOA-No. 22-0912.01
Expiration Date 11/20/2024
By *[Signature]*
Miami-Dade Product Control

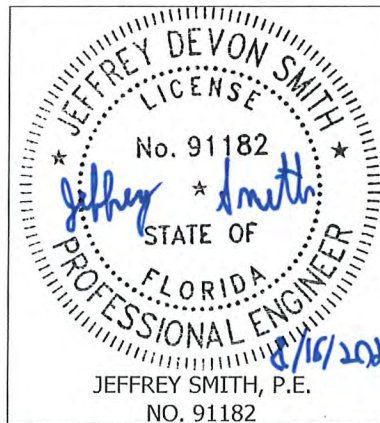

CHK'D. BY: CJD	CHK'D. BY: SDL	APP'D. BY: MMM	APP'D. BY:
DATE: 12/4/17	DATE: 12/4/17	DATE: 12/4/17	DATE:

SHEET 10 OF 11

(A)	REVD ENGINEER OF RECORD, TITLE BLOCK	NS	XXX	XXX	12040	08/12/22
CHANGE LETTER	REVISION DESCRIPTION	DIVL. BY:	CHK'D. BY:	APP'D. BY:	ECN	DATE
PENN BARRY 605 Shiloh RD Plano, TX 75074		FLOT SCALE NONE		ECN 12040		
TITLE PHHW PENNHOUSE DETAILS					DWG. NO. 60-022497-00D	

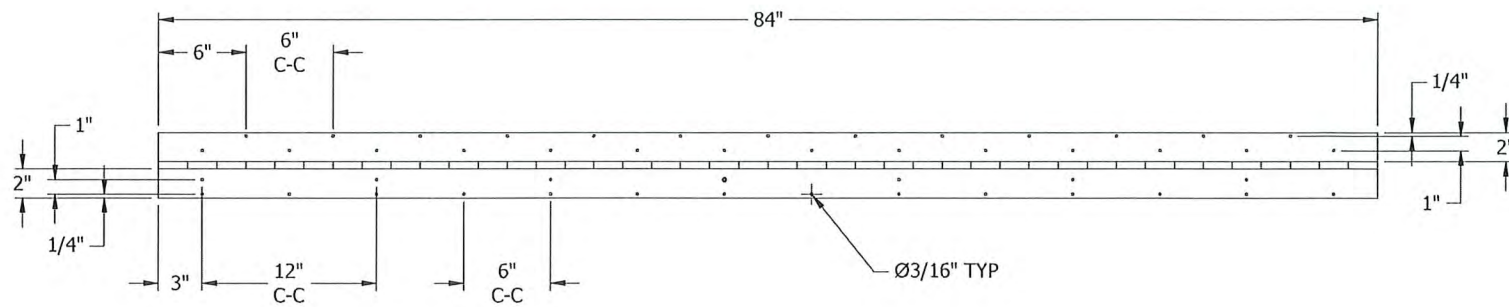

ITEM 18 - HINGE
NTS

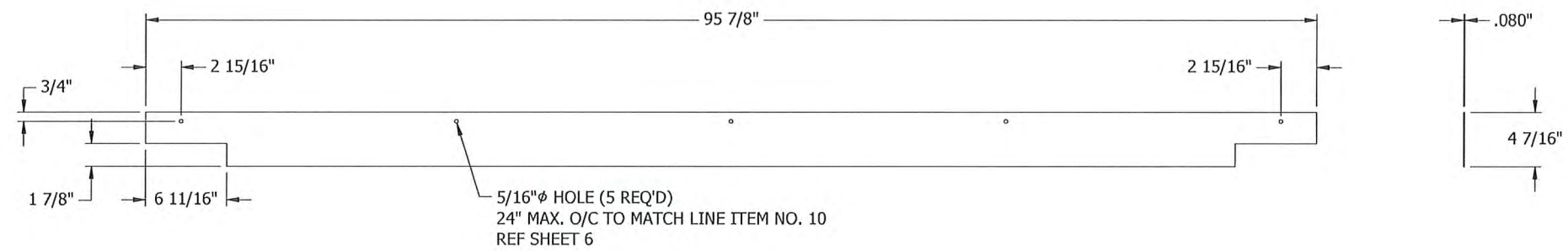

ITEM 22 - 4 7/16"X95 7/8"X.080" HINGED DOOR END PLATE
NTS

NOTES:
1. REF SHEET 6 FOR MATERIAL.

FOR OFFICE USE ONLY

PRODUCT REVISED
as complying with the Florida Building Code
NOA-No. 22-0912.01
Expiration Date 11/20/2024
By *[Signature]*
Miami-Dade Product Control

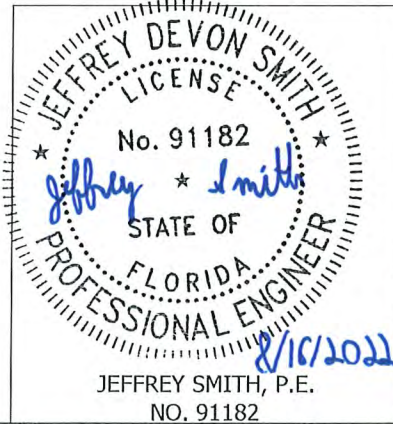

DATE: 12/4/17	DATE: 12/4/17	DATE: 12/4/17	DATE: 12/4/17
BY: CJD	BY: SDL	BY: MMM	BY: []

SHEET 11 OF 11

REV'D ENGINEER OF RECORD, TITLE BLOCK	NS	XXX	XXX	12040	08/12/22
CHANGE LETTER	REVISION DESCRIPTION	DRAWN BY:	CHK'D BY:	APP'D. BY:	ECN
605 Shiloh RD Plano, TX 75074		PLOT SCALE		12040	
PHHW PENNHOUSE DETAILS		DWG. NO. 60-022497-00D			