

MXI

Mixed Flow Inline Fan

PRODUCT GUIDE

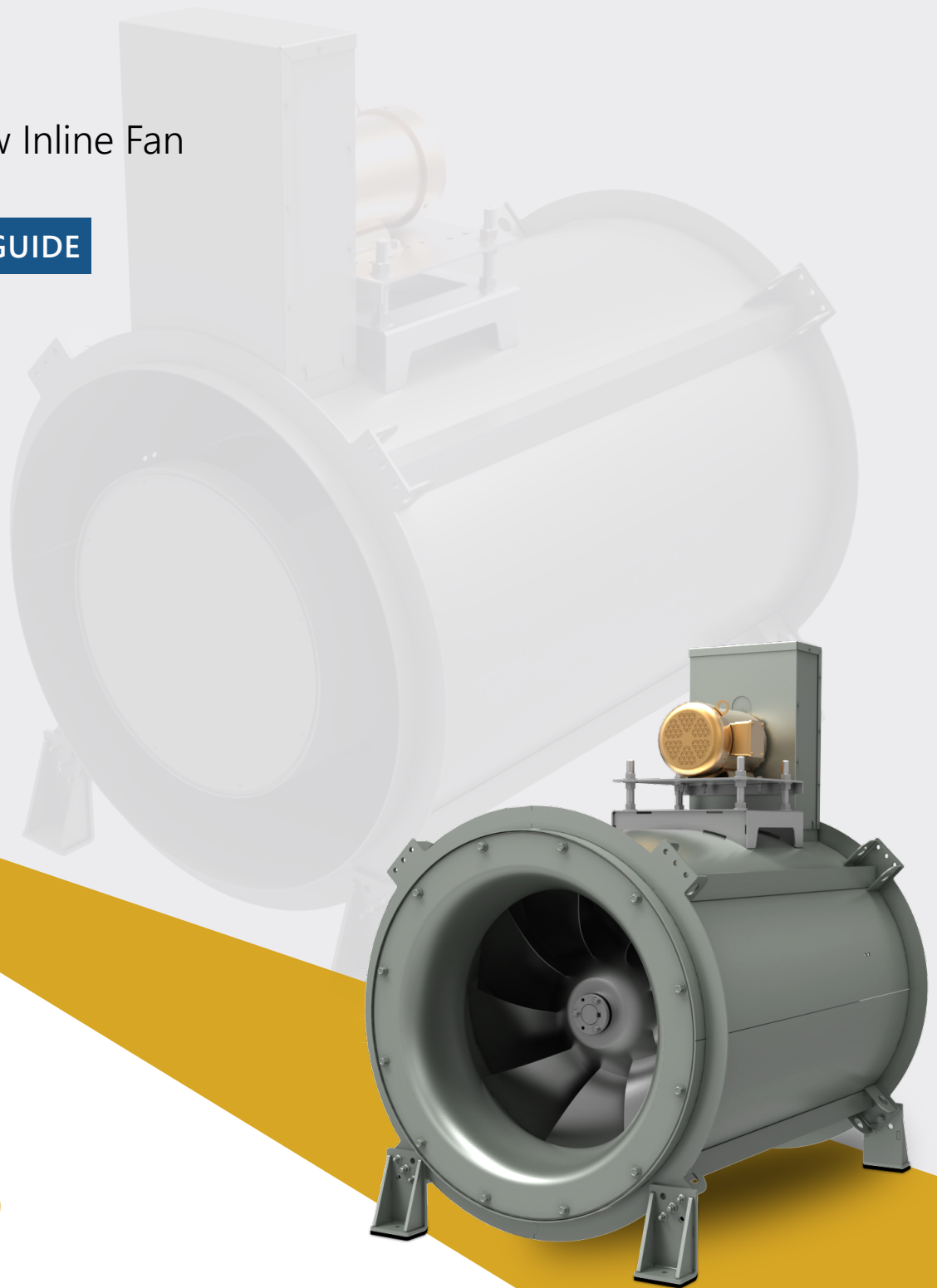

PENNBARRY™

TABLE OF CONTENTS

INTRODUCTION	3
CERTIFICATIONS & LISTINGS	4
MIXED FLOW TECHNOLOGY	5
FEATURES AND BENEFITS	6
OPTION & ACCESSORIES	7-9
MOUNTING CONFIGURATIONS	10
DIMENSIONAL DATA-ARRANGEMENT 4	11
DIMENSIONAL DATA-ARRANGEMENT 9	12
FAN SELECTIONS	13-15

INTRODUCTION

MXI

The PennBarry™ MXI Inline fan utilizes a highly efficient mixed flow wheel suitable for supply, exhaust, or return air applications. Its compact and lightweight design combines the high volume advantage of axial fans with the low sound and higher efficiency of centrifugal fans, and, through its versatility, it even surpasses the efficiency of traditional axial and centrifugal fan technology. Moreover, the outstanding air and sound performance of this fan sets it apart from the competition. Using the most advanced Computational Fluid Dynamics (CFD) software, PennBarry™ designed the MXI wheel to be the best in class for static efficiency among all mixed flow inline fans. With the MXI fan, PennBarry™ brings its innovation to market and sets a new standard for performance by having the most efficient mixed flow fan in the industry.

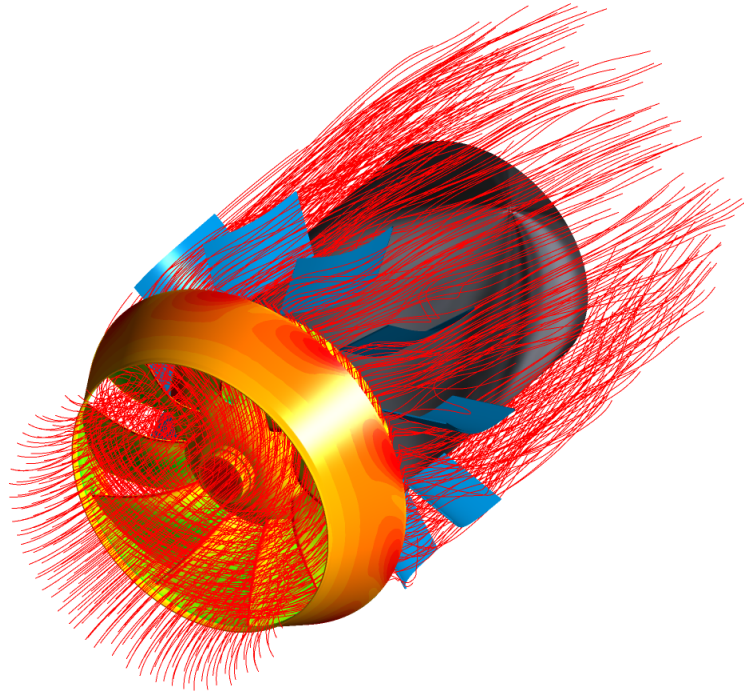

PennBarry used the most advanced CFD software (illustrated above) to ensure the MXI wheel was best in class for static efficiency.

Model: MXI

- Size range from 122-600
- Static pressure up to 8" w.g.
- Flow capacity up to 113,000 CFM
- Available in Arrangements 4 and 9
- Level 1 & 2 Construction

Model: MXI AF

- Size range from 122-445
- Static pressure up to 8.3" w.g.
- Flow capacity up to 60,000 CFM
- Available in Arrangements 4 and 9
- Level 2 Construction

CERTIFICATIONS & LISTINGS



AMCA Certification

PennBarry certifies that the MXI models shown herein are licensed to bear the AMCA seal. The ratings shown are based on tests and procedures performed in accordance with AMCA publication 211 and AMCA publication 311 and comply with the requirements of the AMCA Certified Ratings Program.



cULus Certification

MXI and MXI AF carries the UL label, 705 Power Ventilators (ZACT, ZACT7): File #E28413

MXI with UL762 application option carries the UL762 Power Ventilators for Restaurant Exhaust label, UL762 (YZHW/ YZHW7), file #MH10684.

MXI with Heat and Smoke application option carries the UL Power Ventilators for Smoke Control Systems label, UL793 (ZAXH/ZAXH7), file #MH19473

MIXED FLOW TECHNOLOGY

Mixed Flow : Best of Axial and Centrifugal

By combining aspects from axial propellers and centrifugal wheels, mixed flow wheels produce the benefits of both designs such as: exceptionally efficient air movement, higher static pressures, low ambient noise, and a steep fan curve. The MXI wheel represents the epitome of these impellers due to its status as best in class for static efficiency. However, the benefits of MXI airflow technology do not stop there, as it incorporates straightening vanes into the housing to create even higher static pressures and thus saves energy.

PERFORMANCE COMPARISON
BETWEEN MIXED FLOW-AXIAL-CENTRIFUGAL

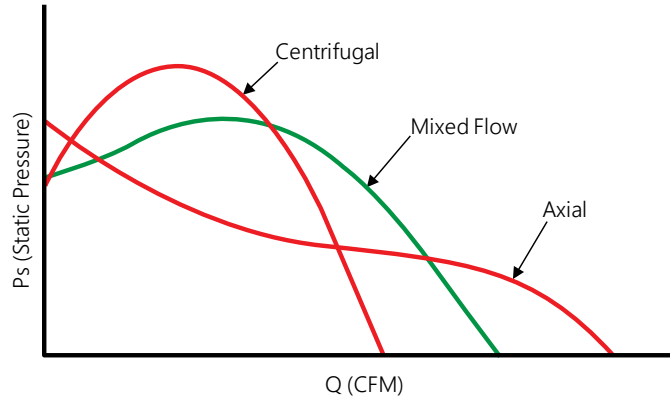

AIRFLOW PROFILES

AXIAL FANS:

Airflow proceeds straight through the fan.

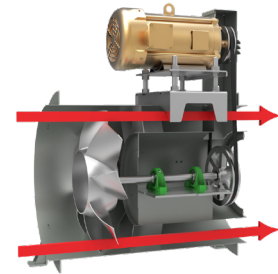

CENTRIFUGAL FANS:

Airflow is diverted at right angles before exiting the fan.

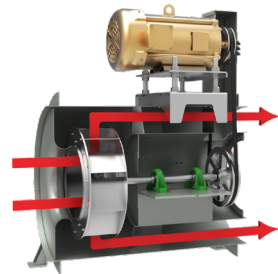

MIXED FLOW FANS:

Airflow is diverted slightly before exiting the fan.

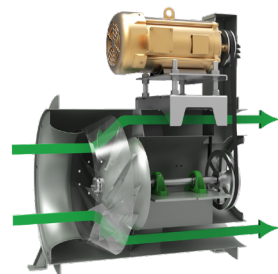

FEATURES AND BENEFITS

Flexible Mounting

MXI include eight mounting brackets to enable horizontal or vertical orientation. Level 1 construction provides 4 bolt on feet and Level 2 construction provides 2 larger, robust bolt on feet.

Bearings (Arrangement 9 only)

Bearings have a minimum L10 life rating of 80,000 hours. Concentric lock mechanism better grips the shaft and reduces vibration more than set screw lock bearings.

Motor

There is a wide variety of motors available for selection, including open drip proof (ODP) and totally enclosed fan cooled (TEFC) premium efficient motors as standard. SGR protection and explosion proof motors are also available. Arrangement 4 units feature totally enclosed motors exclusively.

Speed Controller (Arrangement 4 only)

These speed controllers allow for adjustment in motor rpm, improving productivity and providing a cost effective means for system balancing.

Extended Lube Lines

Factory installed lube lines allow for easy bearing re-lubrication.

Housing

Housings are constructed of heavy gauge steel and are continuously welded so they will be strong and airtight.

Slip fit inlet and outlet

Typical applications for inline fans call for the use of flexible connectors. The MXI is supplied with a slip fit inlet and outlet as standard. This reduces the total fan length and the cost for slip connections.

Belt Guard (Arrangement 9 only)

A totally enclosed belt guard provides protection from rotating pulleys and belts. Belt guards meet OSHA standards.

Heat Resistance

In its standard construction, the MXI is able to propel air with temperatures up to 180 °F.



OPTIONS & ACCESSORIES

Access Door

Bolted or hinged access door provides easy access for inspection and maintenance of fan interior.

Safety Service Switch

Safety service switches are available to allow positive electrical shut-off and safety. NEMA 1 and 3R switches are factory mounted when factory wiring is requested, others will be shipped loose. Wiring is only run from the motor to the junction box. (Factory wiring of explosion proof applications is not available.) A wide range of NEMA rated enclosures with service switches are available for indoor, outdoor, and explosion proof installations. Service switches are to be field wired by a licensed electrician.

Inlet and Outlet Guards

Guards are recommended whenever there is an unducted inlet or outlet. They protect personnel from injury and guard against foreign objects entering the fan. Inlet guards are heavy gauge zinc plated steel wire. Outlet guards are heavy gauge wire.

Variable Frequency Drive

Variable frequency drives (VFDs) are designed to meet performance requirements while increasing efficiency. By varying the fan motor input frequency and voltage, the VFD controls the motor speed and torque, helping to improve productivity and lower energy consumption. The VSC and VSA are ideal for both new and retrofit fan applications. VFD's shipped loose and separately.

Flanges

Flanges facilitate the connection of duct work to the fan. Companion flanges are also available when the unit is connected to duct work by a transition section. The companion flange fits the fan to the transition and guarantees proper sizing.

AMCA Spark Resistant Construction

AMCA "C" and "B" construction are available. AMCA standards offer the following definitions and notes concerning spark-resistant construction:

- C. The fan shall be so constructed that a shift in the impeller or shaft will not permit two ferrous parts of the fan to rub or strike.
- B. The fan shall have a non-ferrous impeller and non-ferrous ring about the opening through which the shaft passes. Ferrous hubs, shafts and hardware are allowed provided construction is such that a shift in impeller or shaft will not permit two ferrous parts of the fan to rub or strike. Steps must also be taken to ensure that the impeller, bearings and shaft are adequately attached and/or restrained to prevent a lateral or axial shift in these components.

Notes:

1. No bearings, drive components or electrical components shall be placed in the air or gas stream unless they are constructed or enclosed in such a manner that failure of that component cannot ignite the surrounding gas stream.
2. The user shall electrically ground on all fan parts.
3. For this standard, non-ferrous material shall be material with less than 5% iron or any other material with demonstrated ability to be spark-resistant.
4. The use of aluminum or aluminum alloys in the presence of steel which has been allowed to rust required special consideration. Research by the U.S. Bureau of Mines and others has shown that aluminum impellers rubbing on rusty steel may cause high-intensity sparking.

The use of the above standard in no way implies a guarantee of safety for any level of spark resistance. Spark-resistant construction does not protect against ignition of explosive gases caused by catastrophic failure or from any airstream material that may be present in a system.

OPTIONS & ACCESSORIES

Vibration Isolators and Hangers

These items are available in both rubber-in-shear and spring type to mitigate residual vibration transmission. All isolators are properly sized to the unit.

Mounting Channel Assembly

Designed for ease of installation, the Mounting Channel Assembly is designed for support in ceiling arrangements. For Arr. 9, mounting channels are recommended for fan assemblies that require both isolators and motor positions at 3 or 9 o'clock. This allows the center of mass of the motor and fan to be positioned between all isolators. Otherwise, "rocking" may occur due to the center of mass being outside the isolators. For Arr. 4, mounting channels enable an upright ceiling hung mounting that mimics a horizontal base mounting configuration.

Copper Lube Lines

As an upgrade for the extended lube lines, copper lube lines are available for selection.

Drains

Drains are available on all fans and are located at the lowest point of the scroll. Standard type is 3/4" NPT external threads. All drains come standard with plugs.

Flexible Duct Connectors

Used as an alternative to rigid connections, these duct connectors are highly recommended since they reduce vibration transmission through the duct work. Available for both indoor and outdoor installations. Outdoor connectors contain UV protection suitable for that environment.

Belt Drive Exclusive Options:

Motor and Weather Covers

Protective covers enclosing the drive assembly, motor, shaft and bearings are available. These covers shield the shaft, bearings and drive from moisture and excessive dirt. Covers specifically designed for adverse weather protection are also available.

Belt Tunnel

This steel tube encloses the fans belts in order to prevent damage to them by debris or high temperatures.

Shaft Seals

A heat resistant ceramic fiber material is used for the seal on the standard shaft seal. Neoprene seals are also supplied.

Extended Life Bearings

As an upgrade to the standard bearings, bearings with an L10 life of 200,000 hours are available for selection.

OPTIONS & ACCESSORIES

Life Safety Drive Kit

All pulleys are sized for at least 150% of the driven horsepower. In order to meet NFPA's Life Safety Code, PennBarry offers this specialized belt drive kit option. In this construction, the drive kit is equipped with 1.5 times the standard number of belts, with a minimum of 2 belts. The drive's pulleys are pre-set to the specified RPM. Adjustable pulleys can be specified, allowing for field balancing based on actual field conditions.

Motor and Weather Covers

Protective covers enclosing the drive assembly, motor, shaft and bearings are available. These covers shield the shaft, bearings and drive from moisture and excessive dirt. Covers specifically designed for adverse weather protection are also available.

UL762 and Heat & Smoke Packages

MXI counts with UL762 and UL Emergency Heat & Smoke packages designed to withstand the temperatures listed below. UL762 and Emergency Heat and Smoke are not available with the Airfoil Impeller.

Belt Drive

UL H&S (500F, 572F) - Horizontal Discharge, Sizes 122-600. Vertical Discharge, Sizes 122-365.

UL762 (400F) - Horizontal Discharge, Sizes 122-600. Vertical Discharge, Sizes 122-365.

Direct Drive

UL H&S (500F, 572F, 1000F) - Horizontal or Vertical Discharge, Sizes 122-600.

UL762 (300F) - Horizontal or Vertical Discharge, Sizes 122-600.

MOUNTING CONFIGURATIONS

BELT DRIVE

HORIZONTAL BASE MOUNT (DISCHARGE VIEW)

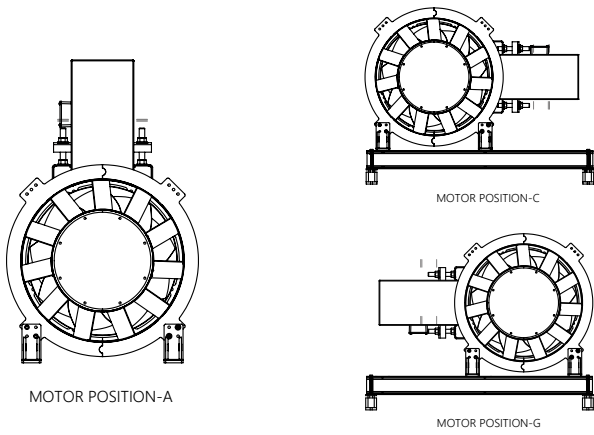

DIRECT DRIVE

HORIZONTAL BASE MOUNT (DISCHARGE VIEW)

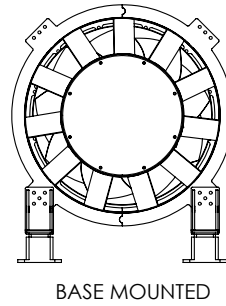

HORIZONTAL CEILING HUNG (DISCHARGE VIEW)

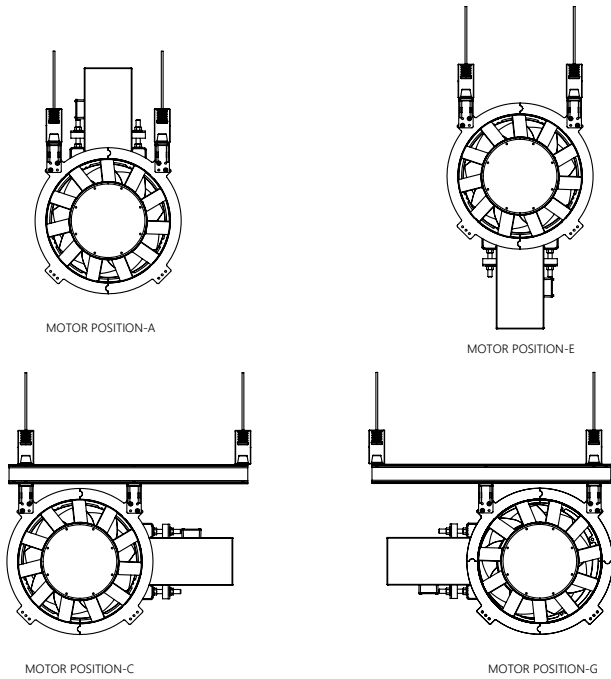

HORIZONTAL CEILING HUNG (DISCHARGE VIEW)

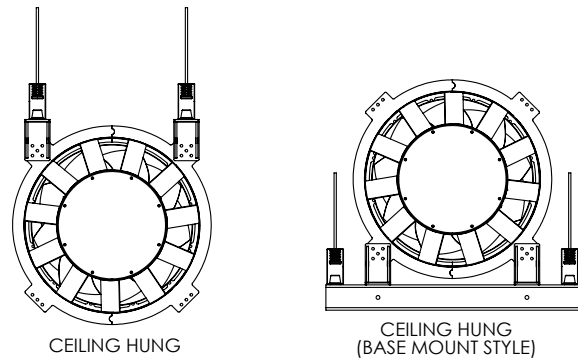

VERTICAL DISCHARGE

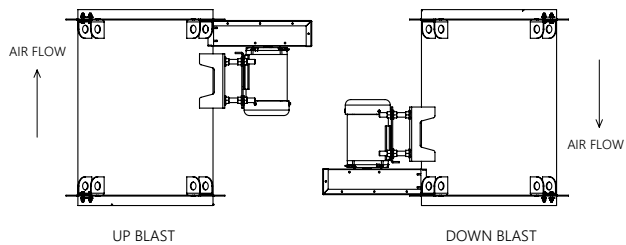

VERTICAL DISCHARGE

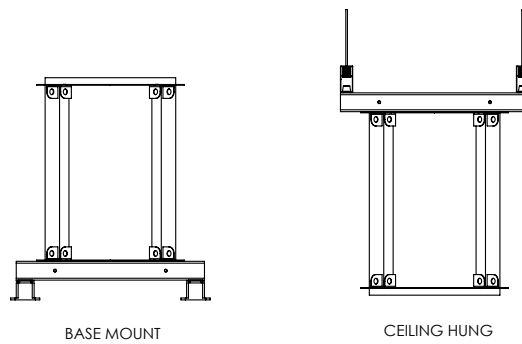

DIMENSIONAL DATA-ARRANGEMENT 4

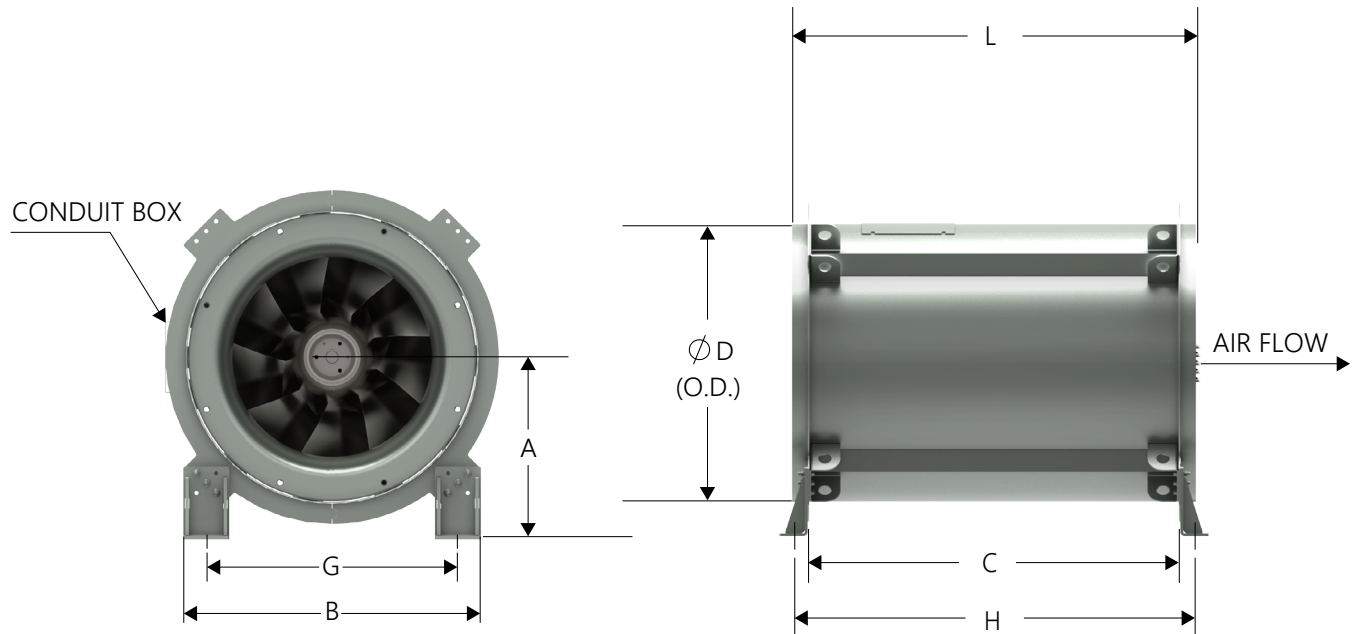

Size	A	B	C	D	G	H	L	Weight (Level1)	Weight (Level2)	Weight (MXI-AF Level 2)
122	12 11/16	20 13/16	21 1/2	17 7/8	16 13/16	25 1/4	25 1/8	139	180	181
135	14	22 1/8	24 3/16	19 3/4	18 1/8	28	27 13/16	169	214	213
150	14 3/4	23 11/16	27 1/4	21 7/8	19 11/16	31 1/16	30 7/8	197	250	254
165	15 5/16	24 3/4	30 3/8	23 3/8	20 3/4	34 1/8	33 15/16	226	285	290
182	16 3/16	26 1/2	33 7/8	25 13/16	22 1/2	37 5/8	37 7/16	291	352	357
200	17 1/16	28 5/16	37 9/16	28 3/8	24 5/16	41 5/16	41 3/16	339	426	430
222	19 5/8	32 1/8	42 1/16	31 7/16	27 1/8	45 7/8	45 11/16	476	535	528
245	20 7/8	34 7/16	46 13/16	34 11/16	29 7/16	52 1/16	50 7/16	572	636	632
270	22 1/8	36 15/16	51 15/16	38 3/16	31 15/16	57 1/4	55 9/16	716	762	771
300	24 3/4	40 5/8	58 1/8	42 7/16	35 5/8	63 7/16	61 3/4	861	937	927
330	26 1/4	43 5/8	64 3/8	46 5/8	38 5/8	69 5/8	68	1007	1090	1102
365	29	47 5/8	71 1/2	51 9/16	42 1/8	77 1/16	75 1/8	1358	1337	1334
402	31 7/8	51 1/8	79 1/8	56 3/4	45 13/16	84 11/16	82 3/4	1633	1591	1549
445	34 5/16	56 5/16	88	62 13/16	50 13/16	93 1/2	91 5/8	1909	1879	1825
490	38 1/2	63 3/4	97 1/4	69 1/8	56 1/4	104 1/4	100 7/8	2565	2451	--
542	41 7/16	69 5/8	107 15/16	76 7/16	62 1/8	115	111 9/16	2984	2903	--
600	46 1/2	76 3/8	119 7/8	84 9/16	67 3/8	126 15/16	123 1/2	3606	3482	--

All dimensions are in inches

DIMENSIONAL DATA-ARRANGEMENT 9

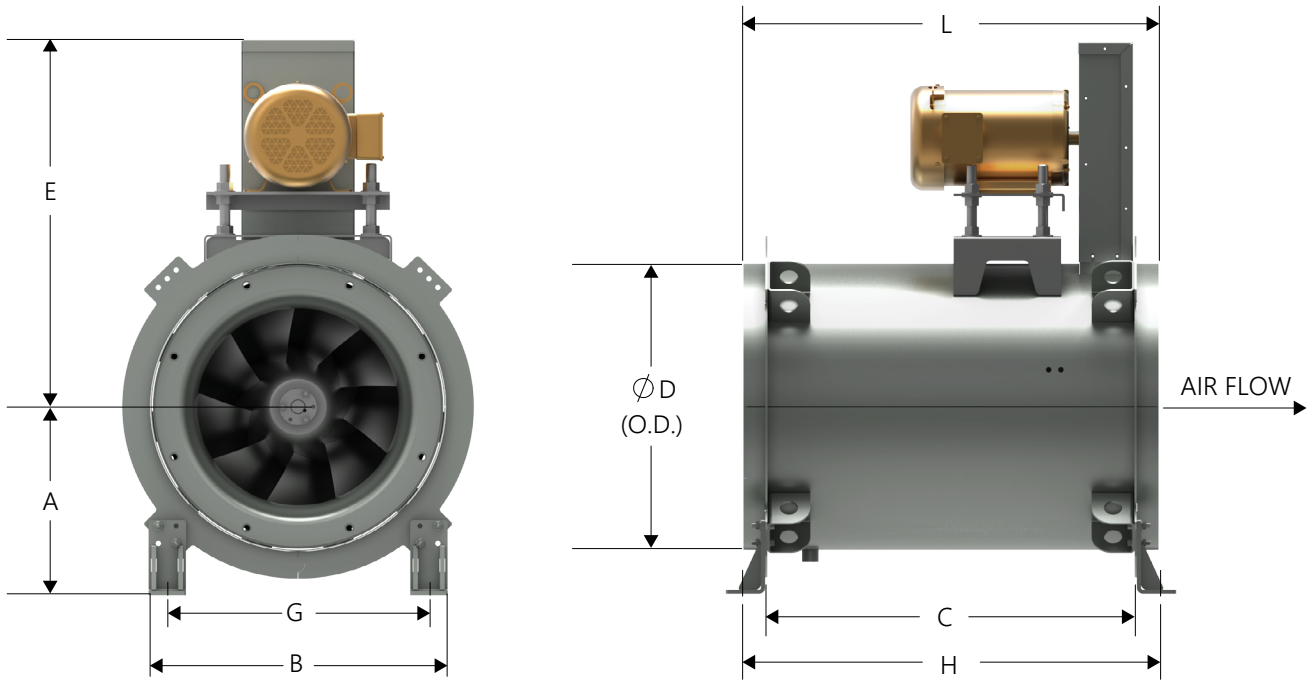

Size	A	B	C	D	E	G	H	L	Weight (Level1)	Weight (Level2)	Weight MXI-AF Level 2
122	12 11/16	19 3/4	21 1/8	17 5/8	24 3/8	16 13/16	25	25 1/8	186	236	237
135	14	21 1/8	21 13/16	19 1/2	25 5/16	18 1/8	27 11/16	27 13/16	218	271	270
150	14 3/4	22 11/16	26 7/8	21 11/16	26 7/16	19 11/16	30 3/4	30 7/8	249	320	324
165	15 5/16	23 3/4	30	23 3/16	27 3/16	20 3/4	33 7/8	34	280	358	363
182	16 3/16	25 1/2	33 1/2	25 9/16	30 3/4	22 1/2	37 3/8	37 1/2	362	468	473
200	17 1/16	27 5/16	37 3/16	28 1/16	32 1/2	24 5/16	41 1/16	41 3/16	449	546	550
222	19 5/8	31 1/8	41 3/4	31 3/16	34 9/16	27 1/8	45 5/8	45 11/16	587	673	666
245	20 3/4	34 3/8	46 7/16	34 7/16	37 13/16	29 3/8	50 5/16	50 3/8	714	796	792
270	22	36 15/16	51 9/16	37 15/16	40 1/4	31 15/16	55 1/2	55 5/8	856	936	945
300	24 3/4	40 5/8	57 5/8	42 1/8	43 3/16	35 5/8	61 5/8	61 13/16	1027	1154	1144
330	26 1/4	43 5/8	63 7/8	46 3/8	46 1/16	38 5/8	67 7/8	67 7/8	1185	1343	1355
365	29	46 5/8	71 1/2	51 1/4	52 3/4	42 1/8	78	75 1/8	1227	1878	1875
402	31 13/16	50 13/16	79 1/8	56 1/2	55 7/8	45 13/16	86 1/8	82 13/16	1535	2260	2218
445	34 5/16	55 13/16	88	62 1/2	59 3/8	50 13/16	95	91 5/8	1980	2732	2678
490	38 1/2	63 3/4	97 1/4	68 13/16	62 9/16	56 1/4	103 3/4	100 7/8	2511	3175	--
542	41 7/16	69 5/8	108 15/16	76 1/8	67 3/16	62 1/8	114 7/16	111 5/8	3022	3753	--
600	46 1/2	76 3/16	119 7/8	84 5/16	71 1/4	67 3/16	126 3/8	123 1/2	4382	4480	--

All dimensions are in inches

FAN SELECTIONS

Model

MXI-Mixed Flow Inline Fan

Construction

<p>Tag <enter value></p> <p>Altitude <enter value></p> <p>Temperature (°F) <enter value></p> <p>Application Flow (CFM) <enter value></p> <p>Application Static Pressure (inwg) <enter value></p> <p>Unit size 122 135 150 165 182 200</p>	<p>222 245 270 300 330 365 402 445 490 542 600</p> <p>Drive Type B = Belt D = Direct</p> <p>Fan Speed <####></p> <p>Open 0</p>	<p>Arrangement D = Arr. 4 Horizontal Base E = Arr. 4 Ceiling Hung F = Arr. 4 Vertical Downblast G = Arr. 4 Vertical Upblast L = Arr. 9 Horizontal Base M = Arr. 9 Horizontal Ceiling Hung N = Arr. 9 Vertical Downblast P = Arr. 9 Vertical Upblast</p> <p>Impeller Type B = Backward Inclined A = Airfoil</p> <p>Class A = Level 1 B = Level 2</p> <p>Open 0</p>
---	--	---

Motor

<p>Motor Position 0 = None A = 0 degrees B = 45 degrees C = 90 degrees D = 135 degrees E = 180 degrees F = 225 degrees G = 270 degrees H = 315 degrees</p> <p>Motors and Drives F = Factory supplied</p>	<p>L = Less motor, less drive N = Customer supplied motor, factory mounted X = Special</p> <p>V-Belt Drive Kit 0 = None A = Adjustable drive kit B = Adjustable drive kit 2.0 service factor C = Constant drive kit E = Constant drive kit 2.0 service factor L = Life safety</p>	<p>X= Special</p> <p>Bearing Life 0 = Standard B = L10 80K Hours E = L10 200K Hours X = Special</p> <p>Open 0</p>
--	---	---

FAN SELECTIONS

Options and Accessories

Paint/Coating

A = Standard Enamel
Q = Airdry phenolic with UV protection
R = High Temp Black
X = Special
* Colors only available in Standard Enamel

Paint Color*

0 = None
A = Standard color (gray)
B = Chrome green
C = Pale green
D = Dove gray (PPC standard)
E = White
F = Oxford beige
G = Dover white
H = Desert tan
J = Black
K = Smoke gray
L = Brick red
M = Peppercorn
N = Pale brown
P = Chocolate brown
Q = Timeless bronze
R = Charcoal
X = Special

* Colors only available for Standard Enamel.

UL / ETL Listing

0 = None
1 = UL 705
3 = UL 762 Restaurant Exhaust
4 = UL Heat and Smoke

Horsepower

0.250 = 1/4
0.333 = 1/3
0.500 = 1/2
0.750 = 3/4
1.00 = 1
1.50 = 1 1/2
2.00 = 2
3.00 = 3
5.00 = 5
7.50 = 7 1/2
10.00 = 10
15.00 = 15
20.00 = 20
25.00 = 25
30.00 = 30
40.00 = 40
50.00 = 50
60.00 = 60
75.00 = 75
X = Special

Motor Enclosure

0 = None
1 = TEFC
2 = TENV
3 = TEAO
4 = OPAO
5 = ODP
6 = OP (Open)
7 = EXP C2D1
X = Special

Efficiency

M = Gplus (Permanent Magnet)
P = Premium
S = Standard

Voltage

A = 115V
B = 208V
C = 230V
D = 277V
F = 460V
G = 575V
H = 220V
J = 380V
K = 400V

Phase

1 = 1 Phase
3 = 3 Phase

Frequency

5 = 50 Hz
6 = 60 Hz

Frame

0 = Factory Supplied
A = 48
B = 56
C = 143T
D = 145T
E = 182T
F = 184T
G = 213T
H = 215T
J = 254T
K = 256T
L = 284T
M = 286T
N = 324T
P = 326T
Q = 364T
R = 365T
S = 404T
T = 405T
U = 444T
X = Special

Motor Speed

B = 1200 RPM
C = 1800 RPM
D = 3600 RPM
F = 1000 RPM
G = 1500 RPM
H = 3000 RPM
T = 870 RPM

Shaft Grounding Ring

0 = None
S = Shaft Grounding Ring

Thermal Overload Protection

0 = None
T = Thermal Overload Protection

Open

0

VFD / Speed Controllers / Starters

0 = None
M = On board motor speed controller // IP22 or less
N = On board motor speed controller // IP52 or better
P = On board motor speed controller (IP52 or better) with disconnect switch
V = VFD
F = Field Provided VFD

Open

0

Motor, Shaft and Belt Guards

0 = None
C = Weather/motor cover
B = Belt guard
W = Weather/motor cover and Belt guard (Tunnel)

Open

0

Service Switches

0 = None
A = NEMA 1 - loose
C = NEMA 1 - mounted
D = NEMA 3R - loose
F = NEMA 3R - mounted
G = NEMA 4 - loose
H = NEMA 4 - mounted
N = NEMA 7/9 - loose

FAN SELECTIONS

Options and Accessories

Internal Wiring

- 0 = None
- 1 = NEMA 1
- 3 = NEMA 3
- 4 = NEMA 4

Spark Resistant Construction

- 0 = None
- B = AMCA B Spark Resistance
- C = AMCA C Spark Resistance

Access Doors

- 0 = None
- 1 = Access door bolted
- T = Access doors hinged

Inlet and Outlet Guards / Screens

- 0 = None
- N = Inlet guard
- U = Outlet guard
- T = Inlet and outlet guard

Inlet Flange

- 0 = None
- A = Punched inlet flange
- G = Punched companion inlet flange kit*

Outlet Flange

- 0 = None
- A = Punched outlet flange
- G = Punched companion outlet flange kit*

Shaft Seal

- 0 = None
- C = Ceramic
- N = Neoprene

Open

0

Vibration Isolators

- 0 = None
- 1 = Rubber in shear floor
- 2 = Rubber in shear hanger
- 4 = Unhoused spring floor
- 5 = Housed spring floor
- 6 = Spring hanger
- X = Special

Extended Lube Lines

- C = Extended copper lube lines
- L = Extended polyamide lube lines

Drain

- 0 = None
- 9 = Drain 3/4" NPT w/ plug

Open

0

Piezometer Ring

- 0 = None
- R = Piezometer Ring

Open

0

Crating Option

- 0 = Standard
- 1 = Premium 1
- 2 = Premium 2

Wheel Width

<xx> = Future

Flex Duct Connector

- 0 = None
- A = Outdoor single connector
- B = Outdoor double connector
- C = Indoor single connector
- D = Indoor double connector

Upblast Kit

- 0 = None
- U = Upblast Kit

Support Channels

- 0 = None
- M = Mounting channel

PENNBARRYPRODUCTSOLUTIONS



Commercial

- Roof & wall exhaust centrifugal fans
- Ceiling, wall, & inline centrifugal fans
- Roof supply centrifugal fans
- Square & round centrifugal fans
- Wall mounted axial fans
- Hooded roof axial fans
- Upblast roof axial fans
- Gravity ventilators
- Roof curbs



Industrial

- Freestanding centrifugal fans
- Industrial & material handling fans
- Tubular centrifugal inline fans
- Mixed flow centrifugal fans
- Plug & plenum fans
- Wall mounted propeller fans
- Tube axial fans
- Vane axial fans
- Bifurcator fans
- Lab exhaust



Kitchen ventilation

- Make-up air units
- Exhaust fans

PennBarry is proud to be your preferred manufacturer of commercial and industrial fans and blowers. Learn how PennBarry can assist you in your next application by contacting your PennBarry Representative or visiting us on the web at www.pennbarry.com

PennBarry | www.pennbarry.com | ptsr@pennbarry.com | Tel 765 483 5800

PennBarry reserves the right to make changes at any time, without notice, to models, construction, specifications, options and availability. This document illustrates the appearance of PennBarry products at the time of publication. View the latest updates on the PennBarry website.

© 2023 PennBarry. All rights reserved. MXI AUGUST 2023.



PENNBARRY™